

INTERNATIONAL STANDARD

NORME INTERNATIONALE



**Luminaires –
Part 1: General requirements and tests**

**Luminaires –
Partie 1: Exigences générales et essais**

IECNORM.COM : Click to view the full PDF of IEC 60598-1:2024



THIS PUBLICATION IS COPYRIGHT PROTECTED
Copyright © 2024 IEC, Geneva, Switzerland

All rights reserved. Unless otherwise specified, no part of this publication may be reproduced or utilized in any form or by any means, electronic or mechanical, including photocopying and microfilm, without permission in writing from either IEC or IEC's member National Committee in the country of the requester. If you have any questions about IEC copyright or have an enquiry about obtaining additional rights to this publication, please contact the address below or your local IEC member National Committee for further information.

Droits de reproduction réservés. Sauf indication contraire, aucune partie de cette publication ne peut être reproduite ni utilisée sous quelque forme que ce soit et par aucun procédé, électronique ou mécanique, y compris la photocopie et les microfilms, sans l'accord écrit de l'IEC ou du Comité national de l'IEC du pays du demandeur. Si vous avez des questions sur le copyright de l'IEC ou si vous désirez obtenir des droits supplémentaires sur cette publication, utilisez les coordonnées ci-après ou contactez le Comité national de l'IEC de votre pays de résidence.

IEC Secretariat
3, rue de Varembe
CH-1211 Geneva 20
Switzerland

Tel.: +41 22 919 02 11
info@iec.ch
www.iec.ch

About the IEC

The International Electrotechnical Commission (IEC) is the leading global organization that prepares and publishes International Standards for all electrical, electronic and related technologies.

About IEC publications

The technical content of IEC publications is kept under constant review by the IEC. Please make sure that you have the latest edition, a corrigendum or an amendment might have been published.

IEC publications search - webstore.iec.ch/advsearchform

The advanced search enables to find IEC publications by a variety of criteria (reference number, text, technical committee, ...). It also gives information on projects, replaced and withdrawn publications.

IEC Just Published - webstore.iec.ch/justpublished

Stay up to date on all new IEC publications. Just Published details all new publications released. Available online and once a month by email.

IEC Customer Service Centre - webstore.iec.ch/csc

If you wish to give us your feedback on this publication or need further assistance, please contact the Customer Service Centre: sales@iec.ch.

IEC Products & Services Portal - products.iec.ch

Discover our powerful search engine and read freely all the publications previews, graphical symbols and the glossary. With a subscription you will always have access to up to date content tailored to your needs.

Electropedia - www.electropedia.org

The world's leading online dictionary on electrotechnology, containing more than 22 500 terminological entries in English and French, with equivalent terms in 25 additional languages. Also known as the International Electrotechnical Vocabulary (IEV) online.

A propos de l'IEC

La Commission Electrotechnique Internationale (IEC) est la première organisation mondiale qui élabore et publie des Normes internationales pour tout ce qui a trait à l'électricité, à l'électronique et aux technologies apparentées.

A propos des publications IEC

Le contenu technique des publications IEC est constamment revu. Veuillez vous assurer que vous possédez l'édition la plus récente, un corrigendum ou amendement peut avoir été publié.

Recherche de publications IEC -

webstore.iec.ch/advsearchform

La recherche avancée permet de trouver des publications IEC en utilisant différents critères (numéro de référence, texte, comité d'études, ...). Elle donne aussi des informations sur les projets et les publications remplacées ou retirées.

IEC Just Published - webstore.iec.ch/justpublished

Restez informé sur les nouvelles publications IEC. Just Published détaille les nouvelles publications parues. Disponible en ligne et une fois par mois par email.

Service Clients - webstore.iec.ch/csc

Si vous désirez nous donner des commentaires sur cette publication ou si vous avez des questions contactez-nous: sales@iec.ch.

IEC Products & Services Portal - products.iec.ch

Découvrez notre puissant moteur de recherche et consultez gratuitement tous les aperçus des publications, symboles graphiques et le glossaire. Avec un abonnement, vous aurez toujours accès à un contenu à jour adapté à vos besoins.

Electropedia - www.electropedia.org

Le premier dictionnaire d'électrotechnologie en ligne au monde, avec plus de 22 500 articles terminologiques en anglais et en français, ainsi que les termes équivalents dans 25 langues additionnelles. Egalement appelé Vocabulaire Electrotechnique International (IEV) en ligne.

INTERNATIONAL STANDARD

NORME INTERNATIONALE



**Luminaire –
Part 1: General requirements and tests**

**Luminaire –
Partie 1: Exigences générales et essais**

INTERNATIONAL
ELECTROTECHNICAL
COMMISSION

COMMISSION
ELECTROTECHNIQUE
INTERNATIONALE

ICS 29.140.40

ISBN 978-2-8322-9936-4

**Warning! Make sure that you obtained this publication from an authorized distributor.
Attention! Veuillez vous assurer que vous avez obtenu cette publication via un distributeur agréé.**

CONTENTS

FOREWORD.....	12
INTRODUCTION.....	15
1 Scope.....	16
2 Normative references	16
3 Terms and definitions	19
4 General requirements	43
4.1 General.....	43
4.2 General test requirements and verification	43
4.3 Components of luminaires.....	45
4.4 Information for luminaire design in light sources and controlgear standards	46
5 Classification of luminaires	46
5.1 General.....	46
5.2 Classification according to the type of protection against electric shock	46
5.3 Classification according to the degree of protection against ingress of dust, solid objects and moisture	46
5.4 Classification according to the material of the mounting surface for which the luminaire is designed	47
5.5 Classification according to the circumstances of use.....	47
6 Marking	47
6.1 General.....	47
6.2 Marking on luminaires	47
6.3 Information to be marked on luminaires	49
6.4 Additional information	58
6.5 Test of marking	63
7 Construction	64
7.1 General.....	64
7.2 Replaceable components	64
7.3 Wireways	64
7.4 Lampholders.....	64
7.5 Starterholders	66
7.6 Terminal blocks.....	66
7.7 Terminals and supply connections	67
7.8 Switches	69
7.9 Insulating linings and sleeves	70
7.10 Double and reinforced insulation.....	70
7.11 Electrical connections and current-carrying parts	72
7.12 Screws, connections (mechanical) and glands	74
7.13 Mechanical strength.....	77
7.14 Suspensions, fixings and means of adjustment	80
7.15 Flammable materials.....	83
7.16 Luminaires for mounting on normally flammable surfaces	85
7.17 Drain holes	87
7.18 Resistance to corrosion	87
7.19 Ignitors	87
7.20 Rough service luminaires.....	87
7.21 Protective shield	89
7.22 Attachments to lamps.....	90

7.23	Semi-luminaires	90
7.24	Photobiological hazards	90
7.24.1	Actinic UV hazards for skin and eye (200 nm to 400 nm)	90
7.24.2	UV-A hazard for the eye lens (315 nm to 400 nm).....	91
7.24.3	Retinal blue light hazard	91
7.24.4	Retinal thermal hazard (380 nm to 1 400 nm)	92
7.24.5	Infrared hazard for the eye (780 nm to 3 000 nm)	93
7.24.6	Thermal hazard for the skin (380 nm to 3 000 nm)	93
7.25	Mechanical hazard.....	93
7.26	Short-circuit protection.....	93
7.27	Terminal blocks with integrated screwless protective earthing contacts.....	94
7.28	Fixing of thermal sensing controls.....	94
7.29	Luminaires with non-replaceable light sources	95
7.30	Luminaires with non-user replaceable light sources and non-user serviceable components.....	95
7.31	Insulation between circuits	95
7.31.1	General	95
7.31.2	SELV or PELV circuits	96
7.31.3	FELV circuits	97
7.31.4	Other circuits.....	97
7.31.5	Additional requirements for luminaires using controllable controlgear providing SELV output(s).....	98
7.32	Overvoltage protective devices external to controlgear	98
7.32.1	General	98
7.32.2	Surge protective devices (SPDs)	99
7.32.3	Surge protective components (SPCs)	99
7.33	Luminaire powered via information technology communication cabling.....	101
7.34	Electromagnetic fields (EMF)	101
7.35	Protection against moving fan blades.....	102
7.36	Track-mounted luminaires.....	102
8	External and internal wiring	102
8.1	General.....	102
8.2	Supply connection and other external wiring	102
8.3	Internal wiring.....	111
8.4	Test to determine the suitability of conductors having a reduced cross-sectional area	113
9	Provision for earthing	114
9.1	General.....	114
9.2	Provision for earthing.....	114
10	Protection against electric shock	117
10.1	General.....	117
10.2	Protection against electric shock.....	117
11	Resistance to dust, solid objects and moisture	121
11.1	General.....	121
11.2	General conditions and tests for IP classification	121
11.2.1	General	121
11.2.2	Tests for first characteristics IP numerals 2, 3 and 4.....	123
11.2.3	Tests for first characteristic IP numeral 5 and 6	123
11.2.4	Drip-proof luminaires – Tests for second characteristic IP numeral 1	124

11.2.5	Drip-proof luminaires – Tests for second characteristic IP numeral 2	125
11.2.6	Rain-proof luminaires – Tests for second characteristic IP numeral 3	125
11.2.7	Splash-proof luminaires – Tests for second characteristic IP numeral 4	126
11.2.8	Jet-proof luminaires – Tests for second characteristic IP numeral 5	126
11.2.9	Powerful jet-proof luminaires – Tests for second characteristic IP numeral 6	127
11.2.10	Watertight luminaires – Tests for second characteristic IP numeral 7	127
11.2.11	Pressure watertight luminaires – Tests for second characteristic IP numeral 8	128
11.2.12	High pressure and temperature water jet-proof luminaires – Tests for second characteristic IP numeral 9 (80 °C)	128
11.2.13	High pressure and cold water jet-proof luminaires – Tests for second characteristic IP numeral 9 (15 °C)	128
11.3	Humidity test	128
12	Insulation resistance and electric strength, touch current and protective conductor current	129
12.1	General	129
12.2	Insulation resistance and electric strength	129
12.2.1	General	129
12.2.2	Test – Insulation resistance	130
12.2.3	Test – Electric strength	131
12.3	Touch current, protective conductor current and electric burn	133
13	Creepage distances and clearances	134
13.1	General	134
13.2	Requirements	135
13.2.1	General	135
13.2.2	Creepage distances	136
13.2.3	Clearances	137
14	Endurance test and thermal test	139
14.1	General	139
14.2	Selection of lamps and controlgear	139
14.3	Endurance test	140
14.3.1	General	140
14.3.2	Test	140
14.3.3	Compliance	141
14.4	Thermal test (normal operation)	141
14.4.1	General	141
14.4.2	Test	142
14.4.3	Compliance	144
14.5	Thermal test (abnormal operation)	147
14.5.1	General	147
14.5.2	Test	148
14.5.3	Compliance	149
14.6	Thermal test (failed windings in controlgear)	151
14.6.1	General	151
14.6.2	Test for luminaires without thermal cut-outs	151
14.6.3	Test for luminaires with temperature sensing controls	152
14.7	Thermal test in regard to fault conditions in controlgear or electronic devices incorporated in thermoplastic luminaires	153
14.7.1	General	153

14.7.2	Test for luminaires without temperature sensing controls	153
14.7.3	Test for luminaires with temperature sensing controls internal or external to the controlgear or transformer	156
15	Resistance to heat, fire and tracking	157
15.1	General	157
15.2	Resistance to heat	157
15.3	Resistance to flame and ignition	158
15.4	Resistance to tracking	158
16	Screw terminals	159
16.1	General	159
16.2	General requirements and basic principles	165
16.3	Mechanical requirements and tests	167
17	Screwless terminals and electrical connections	171
17.1	General	171
17.2	General requirements	173
17.3	General instructions for tests	175
17.3.1	Preparation of samples	175
17.3.2	Test conductors	175
17.3.3	Multi-conductor terminals	175
17.3.4	Multi-way terminals	175
17.3.5	Test quantities	175
17.4	Terminal and connections for internal wiring	175
17.4.1	Mechanical tests	175
17.4.2	Electrical tests	176
17.5	Terminals and connections for external wiring	177
17.5.1	Conductors	177
17.5.2	Mechanical tests	178
17.5.3	Electrical tests	179
Annex A (normative)	Test to establish whether a conductive part can cause an electric shock	181
A.1	General	181
A.2	Touch voltage limits	181
A.3	Touch current limits	181
A.4	Compliance	181
Annex B (normative)	Test lamps	182
B.1	General	182
B.2	Filament lamps within the scope of IEC 60432-1 and IEC 60432-2	182
B.2.1	Principal modes of heat transfer and lamps used for testing	182
B.2.2	Filament test lamps	183
B.3	Halogen lamps within the scope of IEC 60432-3	184
B.4	Tubular fluorescent and other discharge lamps	184
B.5	LED modules within the scope of IEC 62031	184
Annex C (normative)	Abnormal circuit conditions	185
Annex D (normative)	Thermal testing	188
D.1	Draught-proof enclosure	188
D.2	Mounting surface	188
D.3	Alternative test procedure for adjustment of measured temperatures for luminaire t_a rating(s)	189

D.3.1	General	189
D.3.2	Thermal test of normal operation for luminaires without temperature sensing controls and where the rated ambient temperature t_a as marked on the luminaire is higher than the ambient temperature in the draught-proof enclosure.....	189
Annex E (normative)	Determination of winding temperature rises by the increase-in-resistance method	190
Annex F (normative)	Test for resistance to stress corrosion of copper and copper alloys.....	191
F.1	Test cabinet	191
F.2	Test solution	191
F.3	Test piece	191
F.4	Test procedure.....	192
Annex G (normative)	Measurement of touch current and protective conductor current	193
G.1	General.....	193
G.2	Test conditions	193
G.3	Test procedures	193
G.4	Test measurements	193
G.5	Test sequence	195
Annex H (informative)	Explanation of IP numbers for degrees of protection	197
Annex I (informative)	Temperature measurements	199
I.1	Temperature measurements of the luminaire	199
I.2	Temperature measurement of the insulation parts of lampholders	200
Annex J (informative)	Guidelines for good practice in luminaire design	202
J.1	General.....	202
J.2	Plastics in luminaires	202
J.3	Rust resistance	203
J.4	Corrosion resistance	203
J.5	Chemically corrosive atmospheres	204
J.6	Reflector design.....	204
J.7	Components in different kinds of luminaires	205
J.8	Recommendations for electromagnetic ballast protection for end of life phenomenon of HID lamps	205
J.9	Resistance against the effects of vibration	205
J.10	Flammability of components.....	206
J.11	Permanent magnets	206
Annex K (normative)	Determination of creepage distances and clearances	208
Annex L (informative)	Explanation of marking for luminaires that are not suitable for mounting on normally flammable surfaces and covering with insulation materials	209
L.1	General.....	209
L.2	Protection against flame	209
L.3	Protection against heat	210
L.3.1	General	210
L.3.2	Spacing	210
L.3.3	Temperature measurements of mounting surface under abnormal or failed ballast conditions	210
L.4	Thermal protectors.....	212
L.5	Deletion of the F mark requirements	213
Annex M (normative)	Absorption requirements for the protective shield to be fitted to luminaires designed for metal halide lamps which emit a high level of UV radiation	214

M.1	General.....	214
M.2	Procedure A.....	214
M.3	Procedure B.....	215
Annex N (informative) Conformity testing during manufacture		216
N.1	General.....	216
N.2	Testing	216
Annex O (normative) Schedule of amended subclauses containing more serious or critical requirements which call for products to be retested		218
Annex P (normative) Requirements for the identification of a family or range of luminaires for type testing.....		219
P.1	General.....	219
P.2	Range or family of luminaires.....	219
Annex Q (informative) Additional requirements for luminaires where a higher degree of availability (overvoltage category III) may be requested		220
Q.1	General.....	220
Q.2	Requirements for overvoltage category III.....	220
Annex R (normative) Additional test requirements for terminal blocks with integrated screwless protective earthing contact for direct connection to the luminaire housing or to parts of the body.....		222
R.1	Additional requirements to 9.2.1.....	222
R.1.1	Requirements for mechanical strength.....	222
R.1.2	Test for terminal fixing	222
R.1.3	Test for supporting plate.....	222
R.2	Additional requirements to 9.2.3.....	222
Annex S (normative) Alternative thermal test for thermoplastic luminaires		224
S.1	General.....	224
S.2	Thermal test in regard to fault conditions in controlgear or electronic devices without temperature sensing controls in thermoplastic luminaires for fluorescent lamps ≤ 70 W.....	224
Annex T (normative) Requirements for insulation between live parts of circuits and accessible conductive parts.....		226
Annex U (informative) Information regarding power sourcing equipment powering class III luminaires via information technology communication cabling.....		228
U.1	General.....	228
U.2	Insulation of the mains supply	228
U.3	Electrical limits of a PSE.....	228
Annex V (informative) Cross-references to the previous edition of IEC 60598-1		230
Annex W (normative) Battery/EDLC-operated luminaires		233
W.1	General.....	233
W.2	General test requirements and verification	233
W.3	Marking.....	235
W.3.1	General	235
W.3.2	Luminaires with replaceable battery.....	235
W.3.3	Coin and button batteries.....	235
W.3.4	Other standardized batteries (e.g. AAA or AA).....	236
W.3.5	Luminaires with non-standardized replaceable rechargeable battery.....	237
W.3.6	Luminaires with non-user replaceable battery/EDLC	237
W.3.7	Luminaires with non-replaceable battery/EDLC.....	238
W.3.8	Luminaires supplied by external dedicated power supply units.....	238

W.3.9	Rechargeable luminaires other than ordinary	238
W.3.10	Conditions for charging	238
W.4	Construction	239
W.4.1	General	239
W.4.2	Small batteries (coins, button and other non-standardized batteries)	239
W.4.3	Battery compartment fasteners for small batteries and other standardized batteries (e.g. AAA or AA)	240
W.4.4	Battery/EDLC chargers incorporated in luminaires	240
W.4.5	Short-circuit protection	240
W.4.6	Electrical parameters of the batteries operation	241
W.4.7	Protection against overpressure for Li-ion batteries used in luminaires	242
W.4.8	Protection against the consequence of failure of cells or EDLCs	242
W.5	Protection against electric shock	243
W.6	Endurance test and thermal test	243
W.6.1	Endurance test	243
W.6.2	Thermal test (normal operation)	243
W.6.3	Thermal test (abnormal operation)	244
W.6.4	Lithium-ion charging systems – Fault conditions	245
	Bibliography	247
	Figure 1 – Example of "looping-in" (feed through)	30
	Figure 2 – Examples of "through wiring"	30
	Figure 3 – Example of electro-mechanical contact system with plug or socket connection	32
	Figure 4 – AC supply	49
	Figure 5 – DC supply	49
	Figure 6 – DC and AC supply	49
	Figure 7 – Class II	50
	Figure 8 – Class III	50
	Figure 9 – Luminaire not suitable for direct mounting on normally flammable surfaces	52
	Figure 10 – High-pressure sodium lamps that require an external ignitor (to the lamp)	52
	Figure 11 – High-pressure sodium lamps having an internal starting device	52
	Figure 12 – Warning against the use of cool-beam lamps	52
	Figure 13 – Functional earthing	53
	Figure 14 – Protective earthing	53
	Figure 15 – Minimum distance from lighted objects (metres)	54
	Figure 16 – Rough service	54
	Figure 17 – Bowl mirror lamp	54
	Figure 18 – Replace any cracked protective shield	55
	Figure 19 – Test circuit for safety during insertion	55
	Figure 20 – Self-shielded lamp	55
	Figure 21 – Luminaires with internal fuses	56
	Figure 22 – Do not stare at the operating light source	56
	Figure 23 – Caution, risk of electric shock	57
	Figure 24 – Use of heat resistant supply cables, interconnecting cables or external wiring	58

Figure 25 – Pictogram for non-replaceable light source.....	60
Figure 26 – Pictogram for non-user replaceable light source.....	61
Figure 27 – Pictogram for replaceable light source	61
Figure 28 – Pictogram for non-replaceable controlgear	62
Figure 29 – Pictogram for non-user replaceable controlgear	63
Figure 30 – Pictogram for replaceable controlgear	63
Figure 31 – Terminal block arrangement for installation test for luminaires with connecting leads (tails)	67
Figure 32 – Examples of self-tapping, thread-cutting and thread-forming screws	73
Figure 33 – Illustration of the requirements of 7.15.1	84
Figure 34 – Apparatus for ball impact tests	88
Figure 35 – Test chain	94
Figure 36 – Example of permitted degree of soldering	109
Figure 37 – Circuit for checking electrical contact between socket-outlet and plug	110
Figure 38 – Test to determine the suitability of conductors having a reduced cross-sectional area	114
Figure 39 – Example of a thread-forming screw used in a groove of a metallic material	115
Figure 40 – Apparatus for proving protection against dust.....	124
Figure 41 – Apparatus for testing protection against rain and splashing	125
Figure 42 – Nozzle for spray test	127
Figure 43 – Illustration of creepage and clearance measurements at a supply terminal.....	136
Figure 44 – Test circuit for luminaires incorporating fluorescent lamp ≤ 70 W	154
Figure 45 – Ball-pressure apparatus	157
Figure 46 – Pillar terminals	160
Figure 47 – Screw terminals and stud terminals	162
Figure 48 – Saddle terminals	163
Figure 49 – Lug terminals	164
Figure 50 – Mantle terminals.....	165
Figure 51 – Construction of electrical connections	171
Figure 52 – Examples of spring-type screwless terminals	172
Figure 53 – Further examples of screwless terminals.....	173
Figure C.1 – Circuit for testing rectifying effect (some capacitive starterless ballasts only)	186
Figure C.2 – Circuit for testing rectifying effect (ballasts for single pin lamps).....	186
Figure C.3 – Circuit for testing rectifying effect of some high-pressure sodium and some metal halide lamps	187
Figure G.1 – Test configuration: single-phase equipment on star TN or TT system	195
Figure G.2 – Measuring network, touch current weighted for perception or reaction	196
Figure G.3 – Measuring network, touch current weighted for let-go (for portable class I luminaires).....	196
Figure G.4 – Measuring network, weighted for high frequency	196
Figure I.1 – Placing of thermocouples on a typical lampholder	201
Figure L.1 – Relation between winding temperature and mounting surface temperature.....	211
Figure L.2 – Ignition temperatures of wood as a function of time	212
Figure R.1 – Arrangement for voltage drop test.....	223

Figure T.1 – Declaration of LV_{supply} and U_{out} and the insulation barriers between the light source and accessible parts	226
Table 1 – Marking	48
Table 2 – IP numbers for degree of protection against ingress of dust, solid objects and moisture	51
Table 3 – Identification of extra-low-voltage DC leads and terminations	53
Table 4 – Overview of required Y capacitors	72
Table 5 – Torque tests on screws	75
Table 6 – Torque tests on cable glands	77
Table 7 – Impact energy and spring compression	78
Table 8 – Test on semi-luminaires	82
Table 9 – Test on adjusting devices	83
Table 10 – Nominal discharge current (used in the combination wave test)	100
Table 11 – Supply cord	104
Table 12 – Wiring dimension	105
Table 13 – Tests for cord anchorage	108
Table 14 – Solid-object-proof luminaire test	123
Table 15 – Minimum insulation resistance	130
Table 16 – Electric strength	132
Table 17 – Limits of touch current or protective conductor current and electric burn	134
Table 18 – Minimum creepage distances for AC sinusoidal voltages up to 30 kHz (to be used in conjunction with Annex K)	137
Table 19 – Minimum clearances for working voltages (to be used in conjunction with Annex K)	138
Table 20 – Minimum distances for ignition pulse voltages or equivalent transformed peak voltage U_p	139
Table 21 – Maximum temperatures under the test conditions of 14.4.3, for principal parts	145
Table 22 – Maximum temperatures under the test conditions of 14.4.3, for common materials used in luminaires	146
Table 23 – Maximum temperatures under the test conditions of 14.5.2	149
Table 24 – Maximum temperature of windings under abnormal operating conditions and at 110 % of rated voltage for controlgear	150
Table 25 – Maximum temperature of windings under abnormal operating conditions and at 110 % of rated voltage for controlgear marked "D6"	151
Table 26 – Temperature overshoot time limitation	153
Table 27 – Nominal cross-sectional areas of conductors according to terminal sizes	166
Table 28 – Nominal cross-sectional areas of conductors according to maximum current	167
Table 29 – Composition of conductors	168
Table 30 – Torque to be applied to screws and nuts	169
Table 31 – Pull to be applied to conductor	170
Table 32 – Conductor rating	178
Table 33 – Conductor pull force	178
Table F.1 – pH value of the test solution	191

Table G.1 – Position of switches e, n and p for the measurements of the different classes of luminaires	195
Table H.1 – Degrees of protection indicated by the first characteristic numeral	197
Table H.2 – Degrees of protection indicated by the second characteristic numeral.....	198
Table J.1 – Damaging influences	202
Table K.1 – Determination of creepage distances and clearances (see Table 18, Table 19 and Table 20).....	208
Table L.1 – Guidance on when to use the symbol and its explanation on the luminaire or in the manufacturer's instructions provided with the luminaire.....	209
Table L.2 – Thermal protection operation.....	213
Table N.1 – Minimum values for electrical tests	217
Table Q.1 – Minimum clearance distances for AC sinusoidal working voltages overvoltage category III	220
Table Q.2 – Overview of required Y capacitors.....	221
Table Q.3 – Nominal discharge current (used in the combination wave test)	221
Table T.1 – Insulation requirements between live parts and accessible conductive parts.....	227
Table U.1 – Limits for the electrical parameters of a PSE.....	228
Table U.2 – Electrical parameters for communication cables or connectors.....	229
Table V.1 – Cross-references	230
Table W.1 – Artificial source characteristics.....	234
Table W.2 – Total area of openings for Li-ion cells.....	242
Table W.3 – Volume of air injected at 2 070 kPa.....	242

INTERNATIONAL ELECTROTECHNICAL COMMISSION

LUMINAIRES –

Part 1: General requirements and tests

FOREWORD

- 1) The International Electrotechnical Commission (IEC) is a worldwide organization for standardization comprising all national electrotechnical committees (IEC National Committees). The object of IEC is to promote international co-operation on all questions concerning standardization in the electrical and electronic fields. To this end and in addition to other activities, IEC publishes International Standards, Technical Specifications, Technical Reports, Publicly Available Specifications (PAS) and Guides (hereafter referred to as "IEC Publication(s)"). Their preparation is entrusted to technical committees; any IEC National Committee interested in the subject dealt with may participate in this preparatory work. International, governmental and non-governmental organizations liaising with the IEC also participate in this preparation. IEC collaborates closely with the International Organization for Standardization (ISO) in accordance with conditions determined by agreement between the two organizations.
- 2) The formal decisions or agreements of IEC on technical matters express, as nearly as possible, an international consensus of opinion on the relevant subjects since each technical committee has representation from all interested IEC National Committees.
- 3) IEC Publications have the form of recommendations for international use and are accepted by IEC National Committees in that sense. While all reasonable efforts are made to ensure that the technical content of IEC Publications is accurate, IEC cannot be held responsible for the way in which they are used or for any misinterpretation by any end user.
- 4) In order to promote international uniformity, IEC National Committees undertake to apply IEC Publications transparently to the maximum extent possible in their national and regional publications. Any divergence between any IEC Publication and the corresponding national or regional publication shall be clearly indicated in the latter.
- 5) IEC itself does not provide any attestation of conformity. Independent certification bodies provide conformity assessment services and, in some areas, access to IEC marks of conformity. IEC is not responsible for any services carried out by independent certification bodies.
- 6) All users should ensure that they have the latest edition of this publication.
- 7) No liability shall attach to IEC or its directors, employees, servants or agents including individual experts and members of its technical committees and IEC National Committees for any personal injury, property damage or other damage of any nature whatsoever, whether direct or indirect, or for costs (including legal fees) and expenses arising out of the publication, use of, or reliance upon, this IEC Publication or any other IEC Publications.
- 8) Attention is drawn to the Normative references cited in this publication. Use of the referenced publications is indispensable for the correct application of this publication.
- 9) IEC draws attention to the possibility that the implementation of this document may involve the use of (a) patent(s). IEC takes no position concerning the evidence, validity or applicability of any claimed patent rights in respect thereof. As of the date of publication of this document, IEC had not received notice of (a) patent(s), which may be required to implement this document. However, implementers are cautioned that this may not represent the latest information, which may be obtained from the patent database available at <https://patents.iec.ch>. IEC shall not be held responsible for identifying any or all such patent rights.

IEC 60598-1 has been prepared by subcommittee 34D: Luminaires, of IEC technical committee 34: Lighting. It is an International Standard.

This tenth edition cancels and replaces the ninth edition published in 2020. This edition constitutes a technical revision.

This edition includes the following significant technical changes with respect to the previous edition:

- a) new structure to comply with the ISO/IEC Directives, Part 2;
- b) addition of a new Annex V for comparison with the previous edition;
- c) revision of 7.32 for SPDs and for SPCs;
- d) the terms "live part" and "active part" were reviewed and aligned with the definitions of "live part" and "hazardous live part" given in IEC 60050-195;

- e) revision of 7.14.2 for conductor mechanical stress;
- f) revision of 14.5.2, Item 4 to include controlgear;
- g) revision of 9.2.1 (Earthing) with the deletion of the word "permanently";
- h) revision of Annex N: earth continuity test time;
- i) revision of 7.11.4; 7.14.1; Table 22 (14.4.3): Introduction of requirements for suspension by magnets;
- j) addition of a new Annex W for luminaires using batteries;
- k) clarification of Clause 6 for marking requirements for nature of supply;
- l) addition of a new Subclause 7.31.5: Additional requirements for luminaires using controllable controlgear providing SELV output(s);
- m) revision of 6.4.16: Information to be provided for luminaire having protective earth current > 10 mA;
- n) revision of 6.3.23; 6.4.18; 6.4.24; 7.30 and 10.2.1 for serviceable, non-user serviceable and non-serviceable components;
- o) revision of Annex D: Draught-proof enclosure;
- p) revision of 8.2.1 and 13.2.1: Inconsistencies in the inclusion of the limits of voltage ranges;
- q) revision of 9.2.10 for looping-in;
- r) Revision of Clause 2 and 7.8: update of the reference to IEC 61058-1-1, IEC 61058-1-2 and IEC 61058-2-1. Update of temperature limits in Table 21 (14.4.3) for luminaires incorporating switches according to IEC 60669-1 or IEC 60669-2-1;
- s) revision of 6.3.22 and 7.24 for photobiological safety;
- t) addition of a new Subclause 6.3.27 for marking of mains socket outlet moved from information requirements.

The major changes which can affect certification are given in Annex O.

Annex O shows where a new text has been included which contains more serious or critical requirements requiring products to be re-tested.

The text of this International Standard is based on the following documents:

Draft	Report on voting
34D/1739/FDIS	34D/1751/RVD

Full information on the voting for its approval can be found in the report on voting indicated in the above table.

The language used for the development of this International Standard is English.

This document was drafted in accordance with ISO/IEC Directives, Part 2, and developed in accordance with ISO/IEC Directives, Part 1 and ISO/IEC Directives, IEC Supplement, available at www.iec.ch/members_experts/refdocs. The main document types developed by IEC are described in greater detail at www.iec.ch/publications.

When using this document with already published parts of the IEC 60598-2 series, Annex V of this document is to be used to update the cross-referencing of the relevant part of the IEC 60598-2 series to the new structure of this document. SC 34D projects to update the structure of the IEC 60598-2 series in line with the new structure of this document are to follow.

A list of all parts in the IEC 60598 series, published under the general title *Luminaires*, can be found on the IEC website.

NOTE In this document, the following print types are used:

- requirements: in roman type;
- *test specifications: in italic type;*
- notes: in small roman type.

The committee has decided that the contents of this document will remain unchanged until the stability date indicated on the IEC website under webstore.iec.ch in the data related to the specific document. At this date, the document will be

- reconfirmed,
- withdrawn, or
- revised.

IMPORTANT – The "colour inside" logo on the cover page of this document indicates that it contains colours which are considered to be useful for the correct understanding of its contents. Users should therefore print this document using a colour printer.

IECNORM.COM : Click to view the full PDF of IEC 60598-1:2024

INTRODUCTION

In general, this document covers safety requirements for luminaires. The object of this document is to provide a set of requirements and tests which are considered to be generally applicable to most types of luminaires and which can be called up as required by the detail specifications of the IEC 60598-2 series. This document is thus not regarded as a specification in itself for any type of luminaire, and its provisions apply only to particular types of luminaires to the extent determined by the appropriate part of the IEC 60598-2 series.

Each part of the IEC 60598-2 series details the requirements for a particular type of luminaire or group of luminaires. These parts of the IEC 60598-2 series are published separately for ease of revision and additional documents will be added as and when a need for them is recognized.

The IEC 60598-2 series comprises the following parts:

IEC 60598-2-1:	Fixed general purpose luminaires
IEC 60598-2-2:	Recessed luminaires and recessed air-handling luminaires
IEC 60598-2-3:	Luminaires for road and street lighting
IEC 60598-2-4:	Portable general purpose luminaires
IEC 60598-2-5:	Floodlights
IEC 60598-2-6:	Luminaires with built-in transformer for filament lamps (withdrawn)
IEC 60598-2-7:	Portable luminaires for garden use (withdrawn)
IEC 60598-2-8:	Handlamps
IEC 60598-2-9:	Photo and film luminaires (non-professional) (withdrawn)
IEC 60598-2-10:	Portable luminaires for children
IEC 60598-2-11:	Aquarium luminaires
IEC 60598-2-12:	Mains socket-outlet mounted nightlights
IEC 60598-2-13:	Ground recessed luminaires
IEC 60598-2-14:	Luminaires for cold cathode tubular discharge lamps (neon tubes) and similar equipment
IEC 60598-2-15:	Not used at present
IEC 60598-2-16:	Not used at present
IEC 60598-2-17:	Luminaires for stage lighting, television and film studios (outdoor and indoor)
IEC 60598-2-18:	Luminaires for swimming pools and similar applications
IEC 60598-2-19:	Air-handling luminaires (safety requirements) (withdrawn)
IEC 60598-2-20:	Lighting chains
IEC 60598-2-21:	Rope lights
IEC 60598-2-22:	Luminaires for emergency lighting
IEC 60598-2-23:	Extra-low-voltage lighting systems for filament lamps
IEC 60598-2-24:	Luminaires with limited surface temperatures
IEC 60598-2-25:	Luminaires for use in clinical areas of hospitals and health care buildings

LUMINAIRES –

Part 1: General requirements and tests

1 Scope

This part of IEC 60598 specifies general safety requirements for luminaires, incorporating electric light sources for operation from supply voltages up to 1 000 V.

Requirements for semi-luminaires are included in this document.

For explosion proof luminaires, as covered by the IEC 60079 series, the requirements of the IEC 60598 series (selecting the appropriate parts of the IEC 60598-2 series) are applied in addition to the requirements of the IEC 60079 series. In the event of any conflict between the IEC 60598 series and the IEC 60079 series, the requirements of the IEC 60079 series take priority.

This document does not cover performance. Performance of luminaires is covered by the IEC 62722 series.

2 Normative references

The following documents are referred to in the text in such a way that some or all of their content constitutes requirements of this document. For dated references, only the edition cited applies. For undated references, the latest edition of the referenced document (including any amendments) applies.

IEC 60061-2, *Lamp caps and holders together with gauges for the control of interchangeability and safety – Part 2: Lampholders*, available at <http://std.iec.ch/iec60061>

IEC 60061-3, *Lamp caps and holders together with gauges for the control of interchangeability and safety – Part 3: Gauges*, available at <http://std.iec.ch/iec60061>

IEC 60068-2-6, *Environmental testing – Part 2-6: Tests – Test Fc: Vibration (sinusoidal)*

IEC 60068-2-14:2023, *Environmental testing – Part 2-14: Tests – Test N: Change of temperature*

IEC 60068-2-31:2008, *Environmental testing – Part 2-31: Tests – Test Ec: Rough handling shocks, primarily for equipment-type specimens*

IEC 60068-2-75, *Environmental testing – Part 2-75: Tests – Test Eh: Hammer tests*

IEC TR 60083, *Plugs and socket-outlets for domestic and similar general use standardized in member countries of IEC*

IEC 60085, *Electrical insulation – Thermal evaluation and designation*

IEC 60112:2020, *Method for the determination of the proof and the comparative tracking indices of solid insulating materials*

IEC 60155, *Glow-starters for fluorescent lamps*

IEC 60227 (all parts), *Polyvinyl chloride insulated cables of rated voltages up to and including 450/750 V*

IEC 60238:2016, *Edison screw lampholders*

IEC 60245 (all parts), *Rubber insulated cables – Rated voltages up to and including 450/750 V*

IEC 60320 (all parts), *Appliance couplers for household and similar general purposes*

IEC 60335-1:2020, *Household and similar electrical appliances – Safety – Part 1: General requirements*

IEC 60360, *Standard method of measurement of lamp cap temperature rise*

IEC 60384-14, *Fixed capacitors for use in electronic equipment – Part 14: Sectional specification – Fixed capacitors for electromagnetic interference suppression and connection to the supply mains*

IEC 60417, *Graphical symbols for use on equipment*, available at <http://www.graphical-symbols.info/equipment>

IEC 60432-1:1999, *Incandescent lamps – Safety specifications – Part 1: Tungsten filament lamps for domestic and similar general lighting purposes*

IEC 60432-1:1999/AMD1:2005

IEC 60432-1:1999/AMD2:2011

IEC 60432-2:1999, *Incandescent lamps – Safety specifications – Part 2: Tungsten halogen lamps for domestic and similar general lighting purposes*

IEC 60432-2:1999/AMD1:2005

IEC 60432-2:1999/AMD2:2012

IEC 60529, *Degrees of protection provided by enclosures (IP Code)*

IEC 60570:2003, *Electrical supply track systems for luminaires*

IEC 60570:2003/AMD1:2017

IEC 60570:2003/AMD2:2019

IEC 60598-2 (all parts), *Luminaires – Part 2: Particular requirements*

IEC 60598-2-4:2017, *Luminaires – Part 2-4: Particular requirements – Portable general purpose luminaires*

IEC 60603 (all parts), *Connectors for frequencies below 3 MHz for use with printed boards*

IEC 60662, *High-pressure sodium vapour lamps – Performance specifications*

IEC 60664-4:2005, *Insulation coordination for equipment within low-voltage systems – Part 4: Consideration of high-frequency voltage stress*

IEC 60669-1, *Switches for household and similar fixed-electrical installations – Part 1: General requirements*

IEC 60669-2-1, *Switches for household and similar fixed electrical installations – Part 2-1: Particular requirements – Electronic control devices*

IEC 60684 (all parts), *Flexible insulating sleeving*

IEC 60695-2-11, *Fire hazard testing – Part 2-11: Glowing/hot-wire based test methods – Glow-wire flammability test method for end-products (GWEPT)*

IEC 60695-11-5, *Fire hazard testing – Part 11-5: Test flames – Needle-flame test method – Apparatus, confirmatory test arrangement and guidance*

IEC 60990, *Methods of measurement of touch current and protective conductor current*

IEC 60998-2-1, *Connecting devices for low-voltage circuits for household and similar purposes – Part 2-1: Particular requirements for connecting devices as separate entities with screw-type clamping units*

IEC 60998-2-2, *Connecting devices for low-voltage circuits for household and similar purposes – Part 2-2: Particular requirements for connecting devices as separate entities with screwless-type clamping units*

IEC 61032:1997, *Protection of persons and equipment by enclosures – Probes for verification*

IEC 61051-2:2021, *Varistors for use in electronic equipment – Part 2: Sectional specification for surge suppression varistors*

IEC 61058-1:2016, *Switches for appliances – Part 1: General requirements*

IEC 61058-1-1, *Switches for appliances – Part 1-1: Requirements for mechanical switches*

IEC 61058-1-2, *Switches for appliances – Part 1-2: Requirements for electronic switches*

IEC 61058-2-1, *Switches for appliances – Part 2-1: Particular requirements for cord switches*

IEC 61167, *Metal halide lamps – Performance specification*

IEC 61249 (all parts), *Materials for printed boards and other interconnecting structures*

IEC 61347 (all parts), *Lamp controlgear*

IEC 61347-1:2015, *Lamp controlgear – Part 1: General and safety requirements*
IEC 61347-1:2015/AMD1:2017

IEC 61535:2023, *Installation couplers intended for permanent connection in fixed installations*

IEC 61558 (all parts), *Safety of transformers, reactors, power supply units and combinations thereof*

IEC 61558-1:2017, *Safety of transformers, reactors, power supply units and combinations thereof – Part 1: General requirements and tests*

IEC 61643-11, *Low-voltage surge protective devices – Part 11: Surge protective devices connected to low-voltage power systems – Requirements and test methods*

IEC 61643-331:2020, *Components for low-voltage surge protection – Part 331: Performance requirements and test methods for metal oxide varistors (MOV)*

IEC 61984:2008, *Connectors – Safety requirements and tests*

IEC 62133-2, *Secondary cells and batteries containing alkaline or other non-acid electrolytes – Safety requirements for portable sealed secondary cells, and for batteries made from them, for use in portable applications – Part 2: Lithium systems*

IEC 62368-1:2018, *Audio/video, information and communication technology equipment – Part 1: Safety requirements*

IEC 62391-1, *Fixed electric double-layer capacitors for use in electric and electronic equipment – Part 1: Generic specification*

IEC 62391-2, *Fixed electric double-layer capacitors for use in electronic equipment – Part 2: Sectional specification – Electric double layer capacitors for power application*

IEC 62471-7:2023, *Photobiological safety of lamps and lamp systems – Part 7: Light sources and luminaires primarily emitting visible radiation*

IEC 62493:2015, *Assessment of lighting equipment related to human exposure to electromagnetic fields*
IEC 62493:2015/AMD1:2022

IEC 62680 (all parts), *Universal serial bus interfaces for data and power*

IEC TR 62778:2014¹, *Application of IEC 62471 for the assessment of blue light hazard to light sources and luminaires*

ISO 3864-1, *Graphical symbols – Safety colours and safety signs – Part 1: Design principles for safety signs and safety markings*

ISO 7000, *Graphical symbols for use on equipment – Registered symbols*, available at <https://www.graphical-symbols.info/equipment>

ISO 8124-1:2022, *Safety of toys – Part 1: Safety aspects related to mechanical and physical properties*

3 Terms and definitions

For the purposes of this document, the following terms and definitions apply.

ISO and IEC maintain terminology databases for use in standardization at the following addresses:

- IEC Electropedia: available at <https://www.electropedia.org/>
- ISO Online browsing platform: available at <https://www.iso.org/obp>

NOTE Other definitions related to light sources can be found in the relevant light source standards.

¹ Withdrawn.

3.1 luminaire

apparatus which distributes, filters or transforms the light transmitted from at least one source of optical radiation and which includes, except the sources themselves, all the parts necessary for fixing and protecting the sources, and where necessary, circuit auxiliaries together with the means for connecting them to the power supply

[SOURCE: IEC 60050-845:2020, 845-30-001]

3.2 main part

<of luminaire> part that is fixed to the mounting surface or is directly suspended from it or standing on it

Note 1 to entry: The main part can, or cannot, carry the lamps, lampholders and controlgear.

Note 2 to entry: In luminaires for tungsten filament lamps, the part carrying the lampholder is usually the main part.

3.3 ordinary luminaire

luminaire providing protection against accidental contact with hazardous live parts but without any other special protection against dust, solid objects or moisture

[SOURCE: IEC 60050-845:2020, 845-30-006, modified – "hazardous" has been added.]

3.4 general purpose luminaire

luminaire which is not designed for a special purpose

Note 1 to entry: Examples of general purpose luminaires include pendants, some spotlights and certain fixed luminaires for surface or recessed mounting. Examples of special purpose luminaires are those for rough usage, photo and film applications and swimming pools.

3.5 adjustable luminaire

luminaire whose main part can be turned or moved by means of joints, raising and lowering devices, telescopic tubes or similar devices

Note 1 to entry: An adjustable luminaire can be fixed or portable.

[SOURCE: IEC 60050-845:2020, 845-30-010]

3.6 basic luminaire

smallest number of assembled parts that can satisfy the requirements of any of the parts of the IEC 60598-2 series

3.7 combination luminaire

luminaire consisting of a basic luminaire in combination with one or more parts which may be replaced by other parts, or used in a different combination with other parts and changed either by hand or with the use of tools

3.8**fixed luminaire**

luminaire that cannot easily be moved from one place to another, either because the fixing is such that the luminaire can only be removed with the aid of a tool, or because it is intended for use out of arm's reach

Note 1 to entry: In general, fixed luminaires are designed for permanent connection to the power supply, but connection can also be made by means of a plug or similar device.

[SOURCE: IEC 60050-845:2020, 845-30-013]

3.9**portable luminaire**

luminaire that can easily be moved from one place to another even while connected to the power supply

Note 1 to entry: Luminaires for wall mounting provided with a supply cord for connection to a plug and luminaires which can be fixed to their support by means of a wing screw, a clip or a hook so that they can easily be removed from their support by hand, are considered to be portable luminaires.

[SOURCE: IEC 60050-845:2020, 845-30-011]

3.10**recessed luminaire**

luminaire intended by the manufacturer to be fully or partly recessed into a mounting surface

Note 1 to entry: The term applies both to luminaires for operation in enclosed cavities and to luminaires for mounting through a surface such as a suspended ceiling.

[SOURCE: IEC 60050-845:2020, 845-30-018]

3.11**rated voltage**

supply voltage or supply voltages assigned to the luminaire by the manufacturer

3.11.1**rated constant input voltage**

input voltage or input voltages assigned by the manufacturer for luminaires not equipped with controlgear

Note 1 to entry: The rated constant input voltage of the luminaire corresponds to the rated output voltage of the constant voltage controlgear.

3.12**supply current**

current at the supply terminals when the luminaire has stabilized in normal use at the rated voltage and frequency

Note 1 to entry: The supply current is typically expressed in ampere (A).

[SOURCE: IEC 60050-845:2020, 845-27-120, modified – "when the luminaire has stabilized in normal use at the rated voltage and frequency" has been added.]

3.12.1**rated constant input current**

input current or input currents assigned by the manufacturer for luminaires not equipped with controlgear

Note 1 to entry: The rated constant input current of the luminaire corresponds to the rated output current for constant current controlgear.

**3.13
rated power**

either the number and rated power of the lamps for which the luminaire is designed or the input power of the luminaire in case of other light sources

Note 1 to entry: Other light sources can be LED modules.

**3.14
supply cord**

external flexible cable or cord that is fixed to the luminaire for supply purposes

Note 1 to entry: Luminaires may be provided with the supply cord or designed for attachment of a supply cord e.g. type X or Y attachment.

Note 2 to entry: A supply cord can be termed a non-detachable flexible cable or cord.

**3.15
live part**

<electrical> conductive part intended to be energized under normal operating conditions, including the neutral conductor and mid-point conductor, but excluding the PEN conductor, PEM conductor and PEL conductor

Note 1 to entry: This concept does not necessarily imply a risk of electric shock.

Note 2 to entry: This definition is essentially equivalent to the term "active part" used in the ninth edition of this standard.

Note 3 to entry: For the definitions of PEN, PEM and PEL see IEC 60050-195.

[SOURCE: IEC 60050-195:2021, 195-02-19, modified – The Notes to entry have been added.]

**3.16
hazardous live part**

live part that, under certain conditions, can give a harmful electric shock

Note 1 to entry: The test to determine whether or not a conductive part is a live part which can cause an electric shock is given in Annex A.

Note 2 to entry: The neutral conductor is, however, regarded as a hazardous live part.

Note 3 to entry: This definition is essentially equivalent to the definition of "live part" in the ninth edition of this document.

[SOURCE: IEC 60050-195:2021, 195-06-05, modified – Note 1 to entry has been replaced by three new Notes to entry.]

**3.17
basic insulation**

insulation that provides basic protection

Note 1 to entry: This concept does not apply to insulation used exclusively for functional purposes.

[SOURCE: IEC 60050-195:2021, 195-06-06]

**3.18
basic protection**

protection against electric shock under normal conditions

[SOURCE: IEC 60050-195:2021, 195-06-01]

3.19**supplementary insulation**

independent insulation applied in addition to basic insulation, that provides fault protection

[SOURCE: IEC 60050-195:2021, 195-06-07]

3.20**fault protection**

protection against electric shock under single fault conditions

[SOURCE: IEC 60050-195:2021, 195-06-02]

3.21**double insulation**

insulation comprising both basic insulation and supplementary insulation

[SOURCE: IEC 60050-195:2021, 195-06-08]

3.22**reinforced insulation**

insulation that provides a degree of protection against electric shock equivalent to double insulation

Note 1 to entry: Reinforced insulation can comprise several layers that cannot be tested singly as basic insulation or supplementary insulation.

[SOURCE: IEC 60050-195:2021, 195-06-09]

3.23**protective impedance device**

component or assembly of components whose impedance and construction limit steady-state touch current and electric charge to non-hazardous levels

[SOURCE: IEC 60050-195:2021, 195-06-34]

3.24**class I luminaire**

luminaire in which protection against electric shock does not rely on basic insulation only, but which includes an additional safety precaution in such a way that means are provided for the connection of accessible conductive parts to the protective (earthing) conductor in the fixed wiring of the installation in such a way that accessible conductive parts cannot become a hazardous live part in the event of a failure of the basic insulation

Note 1 to entry: For a luminaire intended for use with a flexible cord or cable, this provision includes a protective conductor as part of the flexible cord or cable.

Note 2 to entry: Class I luminaires may have parts with double insulation or reinforced insulation.

Note 3 to entry: Class I luminaires may have parts in which protection against electric shock relies on operation at safety extra-low voltage (SELV) or protective extra-low voltage (PELV).

3.25

class II luminaire

luminaire in which protection against electric shock does not rely on basic insulation only, but in which additional safety precautions such as double insulation or reinforced insulation are provided, there being no provision for protective earthing or reliance upon installation conditions

Note 1 to entry: A class II luminaire can be one of the following types:

- a) A luminaire having a durable and substantially continuous enclosure of insulating material which envelops all metal parts with the exception of small parts such as nameplates, screws and rivets which are isolated from hazardous live parts by insulation at least equivalent to reinforced insulation. Such a luminaire is called an insulation encased class II luminaire.
- b) A luminaire having a substantially continuous enclosure of metal, insulated from hazardous live parts by insulation at least equivalent to double or reinforced insulation. Such a luminaire is called a metal-encased class II luminaire.
- c) A luminaire which is a combination of types a) and b) above.

Note 2 to entry: The enclosure of an insulation-encased class II luminaire can form a part or the whole of the supplementary insulation or the reinforced insulation.

Note 3 to entry: If functional earthing is provided to assist starting, or for EMC reasons, but is not connected to an accessible metal part, the luminaire may still be deemed to be of class II. Accessible metal parts in compliance with the appropriate IEC lamp specification and other metal parts not normally earthed and not normally accessible during normal use are not regarded to be conductive parts which can cause an electric shock unless the tests of Annex A show them to be hazardous live parts.

Note 4 to entry: If a luminaire with double insulation or reinforced insulation throughout, or both, has a protective earthing terminal or a protective earthing contact, it is a class I construction. However, a fixed class II luminaire can have an internal terminal or contact for maintaining the electrical continuity (e.g. for looping-in or through wiring) of a protective earthing conductor.

Note 5 to entry: Class II luminaires can have parts in which protection against electric shock relies on operation at safety extra-low voltage (SELV) or protective extra-low voltage (PELV).

3.26

class III luminaire

luminaire in which protection against electric shock relies on supply of safety extra-low voltage (SELV) or protective extra-low voltage (PELV) and in which voltages higher than those allowed for SELV or PELV are not generated

Note 1 to entry: An energy source ES1 power sourcing equipment (PSE) fulfilling the requirements of IEC 62368-3:2017 can be regarded as SELV.

3.27

rated maximum ambient temperature

t_a

temperature assigned to a luminaire by the manufacturer to indicate the highest sustained temperature in which the luminaire may be operated under normal conditions

Note 1 to entry: This does not preclude temporary operation at a temperature not exceeding $(t_a + 10)$ °C.

3.28

rated maximum operating temperature

t_c

<of a controlgear or capacitor> highest permissible temperature which can occur on the outer surface (at the indicated place if marked) of the component under normal operating conditions at the rated voltage or maximum of the rated voltage range

3.29 rated maximum operating temperature

 t_w

<of a controlgear winding> winding temperature assigned by the manufacturer as the highest temperature at which electromagnetic controlgear may be expected to have a service life of at least 10 years continuous operation

[SOURCE: IEC 61347-1:2015, 3.17, modified – "a 50 Hz/60 Hz lamp controlgear" has been replaced by "electromagnetic controlgear".]

3.30 ballast

unit inserted between the power supply and at least one discharge lamp that, by means of inductance, capacitance or resistance, single or in combination, serves mainly to limit the current of the discharge lamp(s) to the required value

Note 1 to entry: A ballast can also include means for transforming from the power supply voltage and arrangements which help to provide starting voltage and preheating current, to prevent cold starting, to reduce stroboscopic effect, to correct the power factor and to suppress radio interference.

[SOURCE: IEC 60050-845:2020, 845-28-044]

3.31 electronic step-down convertor

unit inserted between the supply and one or more tungsten-halogen or other filament lamps which serves to supply the lamp(s) with its (their) rated voltage, generally at high frequency

Note 1 to entry: The unit may consist of one or more separate components and may include means for dimming, correcting the power factor and suppressing radio interference.

[SOURCE: IEC 61347-2-2:2011, 3.1, modified – The second part of the definition has been included as a Note to entry.]

3.32 independent controlgear

controlgear consisting of one or more separate elements so designed that it can be mounted separately outside a luminaire, with protection according to the marking of the controlgear and without any additional enclosure

Note 1 to entry: This can consist of a built-in controlgear housed in a suitable enclosure which provides all the necessary protection according to its markings.

[SOURCE: IEC 60050-845:2020, 845-28-055, modified – "lamp controlgear" has been replaced by "controlgear".]

3.33 component

constituent part of a luminaire which cannot be physically divided into smaller parts without losing its function

EXAMPLE LED modules, starters, batteries, controlgear auxiliaries.

Note 1 to entry: Lamps are not considered to be components.

[SOURCE: IEC 60050-151:2001, 151-11-21, modified – "device" has been replaced by "luminaire", "particular" has been deleted, the examples and the Note to entry have been added.]

3.34**built-in component**

component, designed to be built into a luminaire, a box, an enclosure or the like and not intended to be mounted outside a luminaire

[SOURCE: IEC 60050-845:2020, 845-27-062, modified – "LED module" has been replaced by "component", and "form a replaceable part" has been deleted.]

3.35**serviceable component**

component of the luminaire that can be replaced by hand or by the use of common available tools, for the repair or upgrading of the luminaire, or component that is accessible in the luminaire for the adjustment of its operation

EXAMPLE Batteries, controlgear with a settable output characteristic, presence detection devices, fuses, replaceable starters.

Note 1 to entry: Light sources can also be considered to be serviceable components but under the scope of this document the replaceability requirements for light sources are currently covered separately. Lamps are normally always regarded as serviceable light sources.

3.36**non-serviceable component**

component which is a non-replaceable part of the luminaire either because it cannot be replaced or accessed for adjustment without breaking or destroying the luminaire or because it is enclosed under a cover fixed by a fixing means designed to be used only once and which cannot be opened

3.37**non-user serviceable component**

component which can only be replaced or accessed for adjustment by the manufacturer, their service agent, or a similarly skilled person

3.38**integral lampholder**

part of a luminaire which supports the electric lamp and provides electrical contact with it and which is designed as part of the luminaire

[SOURCE: IEC 60050-845:2020, 845-28-026]

3.39**translucent cover**

light-transmitting part of the luminaire which may also protect the lamps and other component parts including diffusers, lens panels and similar light-control elements

3.40**fixed wiring**

cable which is part of the fixed installation to which the luminaire is connected

Note 1 to entry: Fixed wiring can be brought into the luminaire and connected to terminals, including terminals of lampholders, switches and the like.

3.41**appliance coupler****appliance connector**

means enabling a flexible cable to be connected at will to the luminaire consisting of two parts: a connector provided with contact tubes which is the part integral with or designed to be attached to the flexible cable connected to the supply and an appliance inlet, provided with contact pins, which is the part incorporated in or fixed to the luminaire

3.42 external wiring

wiring generally outside the luminaire but delivered with it

Note 1 to entry: External wiring may be used for connecting the luminaire to the supply, to other luminaires, or to any external controlgear.

Note 2 to entry: External wiring is not necessarily outside the luminaire for its full length.

3.43 internal wiring

wiring generally inside the luminaire and delivered with it, which forms the connection between terminations for external wiring or supply cords and terminations of lampholders, switches and similar components

Note 1 to entry: Internal wiring is not necessarily inside the luminaire for its full length.

3.44 normally flammable material

material having an ignition temperature of at least 200 °C and which will not deform or weaken at this temperature

EXAMPLE Wood and materials based on wood of more than 2 mm thickness.

Note 1 to entry: The ignition temperature and the resistance of normally flammable materials to deformation or weakening are based on widely accepted values determined during a test period of 15 min.

3.45 readily flammable surface

surface material which cannot be classified as either normally flammable or non-combustible

EXAMPLE Wood fibre and materials based on wood of up to 2 mm thickness.

3.46 non-combustible surface

surface material incapable of supporting combustion

Note 1 to entry: For the purposes of this document, materials such as metal, plaster and concrete are regarded as non-combustible materials.

3.47 flammable material

material which does not comply with the glow-wire test requirements of 15.3.3

3.48 ELV extra-low voltage

voltage which does not exceed 50 V AC RMS or 120 V ripple free DC between conductors, or between any conductor and earth

Note 1 to entry: "Ripple free" is conventionally defined for sinusoidal ripple voltage as a ripple content of not more than 10 % RMS: the maximum peak value does not exceed 140 V for a nominal 120 V ripple-free DC system, respectively 70 V for a nominal 60 V ripple-free DC system, and 35 V for a nominal 30 V ripple-free system.

Note 2 to entry: For interrupted direct current, for frequencies between 10 Hz and 200 Hz, this document applies a maximum 50 V peak limit for ELV, this limit includes a possible ripple. For frequencies outside this frequency range, the limits of direct current apply. The requirements for the frequency range between 10 Hz and 200 Hz comes from a 1936 research paper, entitled "Electric Shock Effects of Frequency", authored by W.B. Kouwenhoven, D.R. Hooker and E.L. Lotz.

3.48.1**FELV circuit****functional extra-low-voltage circuit**

electric circuit with ELV voltage for functional reason and not fulfilling the requirements for a SELV circuit or PELV circuit

Note 1 to entry: In this document the term "FELV" is used when a FELV circuit is meant.

3.48.2**SELV circuit****safety extra-low-voltage circuit**

electric circuit in which the voltage cannot exceed the value of extra-low voltage

- under normal conditions and
- under single fault conditions, including earth faults in other electric circuits

Note 1 to entry: In this document the term "SELV" is used when a SELV circuit is meant.

Note 2 to entry: Maximum voltage lower than 50 V AC RMS or 120 V ripple free DC may be specified in particular requirements, especially when direct contact with current-carrying parts is allowed.

[SOURCE: IEC 60050-195:2021, 195-06-28, modified – "safety extra-low-voltage circuit" has been added as an admitted term, "system" has been replaced by "circuit" and Note 1 to entry has been replaced by two new Notes to entry.]

3.48.3**PELV circuit****protective extra-low-voltage circuit**

electric circuit in which the voltage cannot exceed the value of extra-low voltage

- under normal conditions and
- under single fault conditions, except earth faults in other electric circuits

Note 1 to entry: In this document the term "PELV" is used when a PELV circuit is meant.

[SOURCE: IEC 60050-195:2021, 195-06-29, modified – "protective extra-low-voltage circuit" has been added as an admitted term, "system" has been replaced by "circuit" and Note 1 to entry has been replaced by a new Note 1 to entry.]

3.49**working voltage**

highest RMS voltage which can occur across any insulation at rated supply conditions, transients being neglected, under normal and under abnormal conditions, including no-load

3.49.1**maximum working peak output voltage**

\hat{U}_{out}

maximum repetitive occurring peak working voltage between the output terminals or between the output terminals and earth, during normal or abnormal operating condition and with transients neglected

[SOURCE: IEC 61347-1:2015, 3.45]

3.49.2**ignition voltage**

peak voltage applied to ignite a discharge lamp

[SOURCE: IEC 61347-1:2015, 3.46]

3.49.3**ignition pulse voltage**

peak ignition voltage with a total duration of $\leq 750 \mu\text{s}$ (summation of all pulses durations) within 10 ms, with the duration time (width) of each pulse being measured at the level of 50 % of the maximum absolute peak value

Note 1 to entry: Ignition pulse waveforms, which are considered as ignition pulse voltage, should not contain any dominant frequency above 30 kHz or should be usually highly damped (after 20 μs the peak voltage level should be less than one half of the maximum peak voltage). For the assessment of the dominant frequency IEC 60664-4:2005, Annex E should be consulted.

[SOURCE: IEC 61347-1:2015, 3.46.1]

3.49.4**equivalent transformed peak voltage** U_p

transformed output peak voltage, which is converted for the worst case peak voltage with its related frequency into an ignition pulse voltage

Note 1 to entry: The value of the declared equivalent transformed output peak voltage is the essential parameter for selecting the associated components.

Note 2 to entry: See 3.49.3.

[SOURCE: IEC 61347-1:2015, 3.47, modified – Notes to entry 3 and 4 have been deleted.]

3.50**type test**

test or series of tests for the purpose of checking compliance of the design of a given product with the requirements of the relevant standard

3.51**type test sample**

sample consisting of one or more similar units being representative of the production and submitted by the manufacturer or the responsible vendor for the purpose of the type test

3.52**by hand**

not requiring the use of a tool

3.53**terminal**

that part of a luminaire or component which is necessary to make an electrical connection to a conductor

Note 1 to entry: See Clause 16 and Clause 17.

3.54**looping-in**

system of mains supply connection to two or more luminaires where each supply conductor is taken into and out of the same terminal

Note 1 to entry: A supply conductor can be cut to facilitate connections to a terminal (see Figure 1).

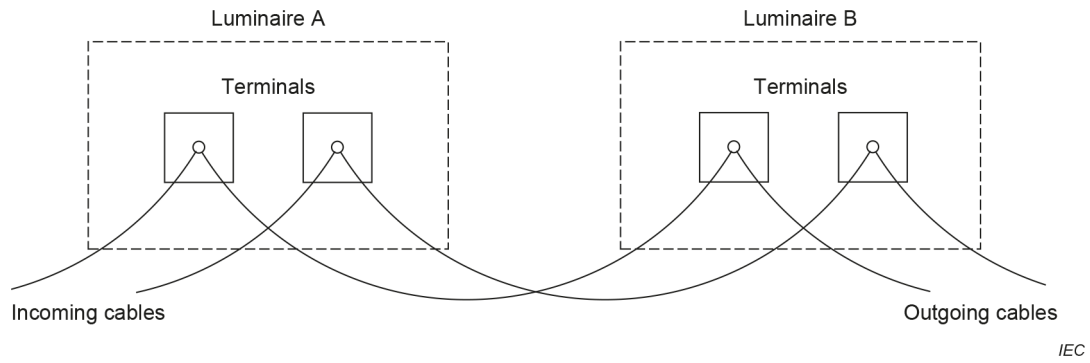

Figure 1 – Example of "looping-in" (feed through)

3.55 through wiring

wiring which passes through the luminaire intended for interconnection of a row of luminaires

Note 1 to entry: Some countries do not permit joints in through wiring.

Note 2 to entry: The luminaire can, or cannot, be electrically connected to the through wiring (see Figure 2).

Note 3 to entry: Through wiring can provide continuity of different types of wiring systems e.g. three phase system.

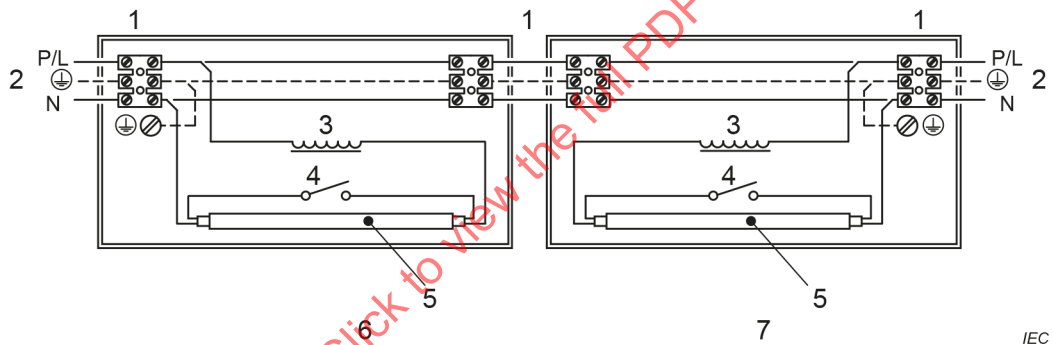

a) "through wiring" with internal wiring electrically connected to the through wiring

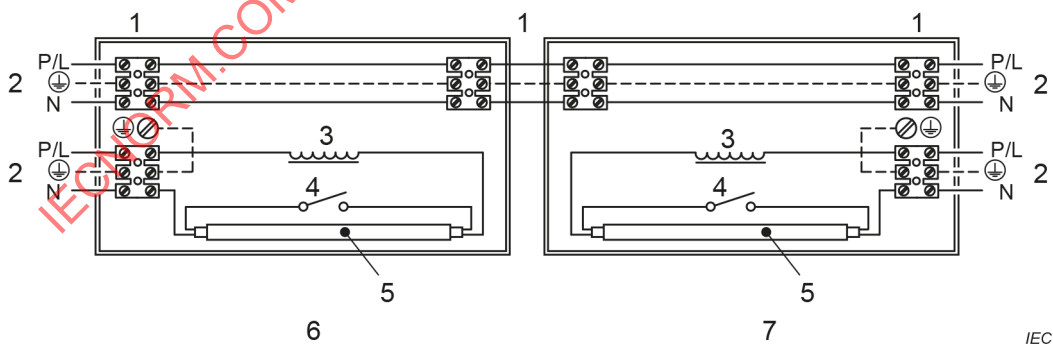

b) "through wiring" with internal wiring electrically separated from the through wiring

Key

- | | | | |
|---|-----------|---|-------------|
| 1 | terminals | 5 | lamp |
| 2 | supply | 6 | luminaire A |
| 3 | ballast | 7 | luminaire B |
| 4 | starter | | |

Figure 2 – Examples of "through wiring"

3.56
starting device

device designed to provide the appropriate electrical conditions to start a discharge lamp by itself or in combination with other components in the circuit

[SOURCE: IEC 60050-845:2020, 845-28-041]

3.57
starter

device, usually for fluorescent lamps, which is used for the purpose of starting the discharge lamp by providing the necessary preheating of the cathode and, in combination with the series inductance of the ballast, causes a voltage surge applied to the discharge lamp

Note 1 to entry: The starter element that releases the starting voltage pulse can be either triggered or non-triggered.

[SOURCE: IEC 60050-845:2020, 845-28-042]

3.58
ignitor

device intended, either by itself or in combination with other components, to generate voltage pulses to start a discharge lamp without providing for the preheating of the electrodes

Note 1 to entry: The element that releases the starting voltage pulse can be either triggered or non-triggered.

[SOURCE: IEC 60050-845:2020, 845-28-043]

3.59
terminal block

assembly of one or more terminals in or on a housing or body of insulating material to facilitate the interconnection between conductors

3.60
rough service luminaire

luminaire designed to withstand severe mechanical handling

Note 1 to entry: The luminaire can:

- be permanently fixed, or
- be temporarily fixed on a construction or stand, or
- incorporate an integral stand or handle.

Note 2 to entry: Rough service luminaires are for use where normally rough circumstances occur, or where temporary lighting is required, for example on building sites, in engineering workshops and for similar applications.

[SOURCE: IEC 60050-845:2020, 845-30-009]

3.61
electro-mechanical contact system

connection system within a luminaire by which the main part carrying the lampholder is electrically and mechanically connected to the base plate or suspension device

Note 1 to entry: Figure 3 describes an electro-mechanical contact system. As such the requirements of 7.11.6 and 9.2.1 apply. Because, in the situation described, the base and gear tray are unique and non-interchangeable, the base plate does not require marking with the rated current of the electrical connection, as specified in 6.2.

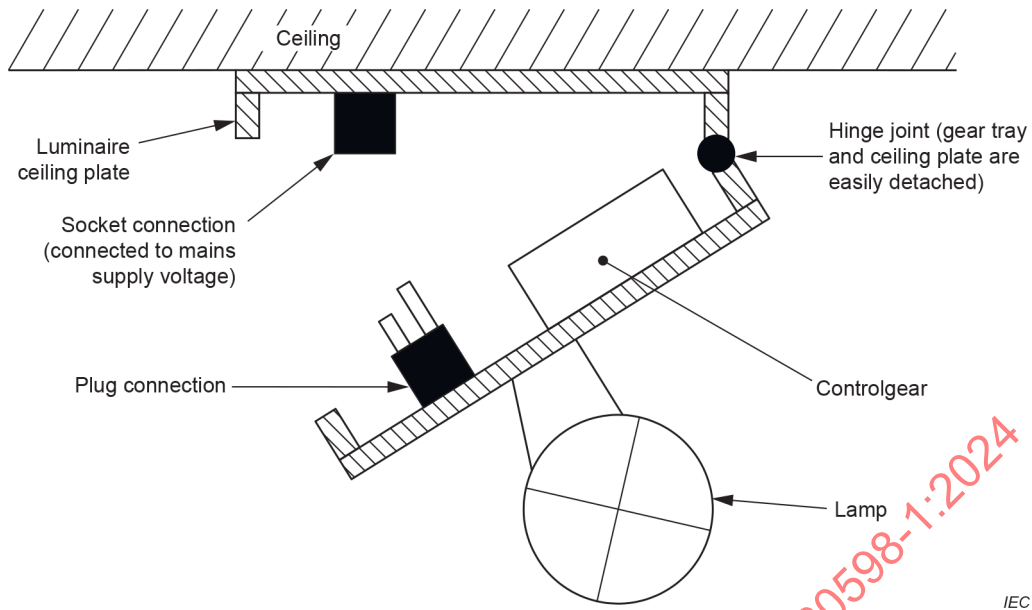

Figure 3 – Example of electro-mechanical contact system with plug or socket connection

Note 2 to entry: The system can incorporate an adjusting device.

Note 3 to entry: The system can be dedicated to a specific luminaire design or can provide for connection of a variety of luminaire types.

3.62 mounting surface

part of any building, furniture or other structure which a luminaire is attached to, suspended from, stood on or placed upon in normal use and which will or is intended to support the luminaire

Note 1 to entry: Lighting tracks, parts of luminaires, controlgear, mounting plates or other housings are not considered to be a mounting surface.

3.63 integral component

component which forms a non-replaceable part of a luminaire and which cannot be tested separately from the luminaire

3.64 integrated lamp self-ballasted lamp

electric lamp that cannot be dismantled without being permanently damaged, incorporating controlgear, and all additional elements necessary for starting and stable operation of the light source, designed for direct connection to the supply voltage

Note 1 to entry: The light source component of an integrated lamp is not replaceable.

Note 2 to entry: The ballast component is part of the integrated lamp; it is not part of the luminaire.

[SOURCE: IEC 60050-845:2020, 845-27-009, modified – The second preferred term "self-ballasted lamp" and the Notes to entry have been added.]

**3.65
semi-luminaire**

unit similar to an integrated lamp, but designed to utilize a replaceable light source and/or a replaceable starting device

Note 1 to entry: The ballast component is not replaceable and is not disposed of each time a light source is replaced.

Note 2 to entry: A lampholder is required for a supply connection.

[SOURCE: IEC 60050-845:2020, 845-30-002]

**3.66
plug-in independent controlgear**

independent controlgear provided with an integral plug as the means of connection to the electrical supply

**3.67
mains socket-outlet mounted luminaire**

luminaire provided with an integral plug as the means of both mounting and connection to the electrical supply

**3.68
clip-mounted luminaire**

integral assembly of a luminaire and resilient spring clip, securing the luminaire in position on its mounting surface by a single hand action

**3.69
lamp connector**

device consisting of electrical contacts, with insulation and mounted on flexible conductors, which provides for connection of the electric lamp to the power supply but does not support the electric lamp

[SOURCE: IEC 60050-845:2020, 845-28-035, modified – The first preferred term "connector" has been deleted.]

**3.70
mains socket-outlet**

accessory having socket-contacts designed to engage with the pins or blades of a mains plug and having terminals for the connection of cables or cords

**3.71
controlgear**

unit inserted between the power supply and at least one light source, which serves to supply the light source(s) with its (their) rated voltage or rated current, and which can consist of one or more separate components

Note 1 to entry: A controlgear can include means for igniting, dimming, correcting the power factor and suppressing radio interference, and further control functions.

Note 2 to entry: A controlgear can consist of a power supply and a control unit.

Note 3 to entry: A controlgear can be partly or totally integrated in the light source.

Note 4 to entry: The terms "control gear" and "controlgear" are interchangeable. In IEC standards, the term "controlgear" is commonly used.

[SOURCE: IEC 60050-845:2020, 845-28-048, modified – The first preferred term "control gear" has been deleted.]

3.72

dummy lamp

device incorporating a cap which is in compliance with the requirements of the IEC 60061 series where applicable

3.73

self-shielded lamp

tungsten-halogen lamp or metal halide lamp for which the luminaire needs no protective shield for protection against UV emission or lamp shattering

[SOURCE: IEC 60050-845:2020, 845-27-094]

3.74

external flexible cable

external flexible cord

flexible cable or cord for external connection to the input or output circuit, fixed to or assembled with the luminaire according to a type X, Y or Z method of attachment

3.74.1

type X attachment

method of attachment of the cable or cord such that it can be easily replaced

Note 1 to entry: The flexible cable or cord may be specially prepared and only available from the manufacturer or their service agent.

Note 2 to entry: A specially prepared cable or cord may also include a part of the luminaire.

3.74.2

type Y attachment

method of attachment of the cable or cord such that any replacement can only be made by the manufacturer, their service agent or a similarly skilled person

Note 1 to entry: Type Y attachment may be used either with an ordinary or a special flexible cable or cord.

3.74.3

type Z attachment

method of attachment of the cable or cord such that it cannot be replaced without breaking or destroying the luminaire

3.75

earthing

3.75.1

protective earthing

earthing for purposes of electrical safety

[SOURCE: IEC 60050-195:2021, 195-01-11, modified – The second preferred term "protective grounding, US" has been deleted.]

3.75.2

functional earthing

earthing for purposes other than electrical safety

Note 1 to entry: Functional earthing can be used to assist the starting of a lamp or to avoid radio interference.

[SOURCE: IEC 60050-195:2021, 195-01-13, modified – The second preferred term "functional grounding, US" has been deleted and Note 1 to entry has been added.]

3.76**interconnecting cable**

wiring or wiring assembly between two main parts of a luminaire as supplied by the luminaire manufacturer and which can be regarded as being part of the luminaire

Note 1 to entry: A wiring assembly can contain a combination of different wiring, e.g. to feed through the supply voltage, to provide earthing, to supply starting and working voltages and wiring providing functional connection. Examples of applications are: between a luminaire and a controlgear box, a mounting box or a connector fitting to a track system.

3.77**ferrule**

mechanical fixture, generally a rigid tube, used to confine the stripped end of a cable

3.78**overvoltage category****impulse withstand category**

numeral defining a transient overvoltage condition

Note 1 to entry: Overvoltage categories I, II, III and IV are used.

Note 2 to entry: The following explanation is taken from IEC 60364-4-443 (withdrawn).

a) Purpose of classification of impulse withstand categories

Impulse withstand categories are to distinguish different degrees of availability of equipment with regard to required expectations on continuity of service and on an acceptable risk of failure.

By selection of impulse withstand levels of equipment insulation, coordination can be achieved in the whole installation reducing the risk of failure to an acceptable level providing a basis for overvoltage control.

A higher characteristic numeral of an impulse withstand category indicates a higher specific impulse withstand of the equipment and offers a wider choice of methods for overvoltage control.

The concept of impulse withstand categories is used for equipment energized directly from the mains.

b) Description of impulse withstand categories

Equipment of impulse withstand category I is equipment which is intended to be connected to the fixed electrical installations of buildings. Protective means are taken outside the equipment – either in the fixed installation or between the fixed installation and the equipment – to limit transient overvoltages to the specific level.

Equipment of impulse withstand category II is equipment to be connected to the fixed electrical installations of buildings.

Equipment of impulse withstand category III is equipment which is part of the fixed electrical installations and other equipment where a higher degree of availability is expected.

Equipment of impulse withstand category IV is for use at or in the proximity of the origin of the electrical installations of buildings upstream of the main distribution board.

3.79**circuits and circuit characteristics****3.79.1****primary circuit**

circuit that is directly connected to the mains supply

Note 1 to entry: It includes, for example, the means for connection to the mains supply, the primary windings of transformers, motors and other loading devices.

[SOURCE: IEC 60950-1:2005, 1.2.8.4 (withdrawn), modified – "AC mains supply" has been replaced by "mains supply", the second part of the definition has been included as Note 1 to entry and the existing note has been deleted.]

3.79.2**secondary circuit**

circuit that has no direct connection to a primary circuit and derives its power from a transformer, converter or equivalent device, or from a battery

Note 1 to entry: In autotransformers, although having direct connection to a primary circuit, the tapped part of the transformer is also deemed to be a secondary circuit in the above sense.

Note 2 to entry: Mains transients in such a circuit are attenuated by the corresponding primary windings. Inductive ballasts also reduce the mains transient voltage height. Therefore, components located after a primary circuit or after an inductive ballast can be suited for an overvoltage category of one step lower, see Annex Q.

[SOURCE: IEC 60950-1:2005, 1.2.8.5 (withdrawn), modified – "equivalent isolation device" has been replaced by "equivalent device" and the note has been replaced by two new Notes to entry.]

3.80**touch current**

electric current passing through a human body or through livestock when it touches one or more accessible parts of an installation or of equipment

Note 1 to entry: In this document, the human body is represented by the networks in Figure G.2 or Figure G.3.

[SOURCE: IEC 60050-195:2021, 195-05-21, modified – The Note 1 to entry has been added.]

3.81**protective conductor current**

electric current appearing in a protective conductor, such as leakage current or electric current resulting from an insulation fault

Note 1 to entry: This current may have an influence on the operation of RCDs (residual current protection devices) connected in the same circuit.

[SOURCE: IEC 60050-195:2021, 195-05-22, modified – The Note 1 to entry has been added.]

3.82**electric burn**

burning of the skin or an organ caused by an electric current along its surface or through it

[SOURCE: IEC 60050-195:2021, 195-03-01]

3.83**means of adjustment**

part of a luminaire, which may be the lamp compartment, obviously intended to be manipulated by the user during use of the luminaire, for example to redirect the light beam

3.84**arm's reach**

zone of accessibility to touch extending from any point on a surface where persons usually stand or move about to the limits that a person can reach with the hand, in any direction, without assistance

Note 1 to entry: IEC 60364-4-41 incorporates a drawing representing the zone of accessibility. In general terms, the height is 2,5 m from the floor, and the width is 1,25 m in all horizontal directions from the location a person may be.

[SOURCE: IEC 60050-195:2021, 195.06.12, modified – The Note 1 to entry has been replaced by a new Note 1 to entry.]

3.85**terminal block with integrated screwless protective earthing contact**

terminal with earthing connection performed by means of an integrated contact or by means of an auxiliary contact without additional assembly actions (e.g. screwing) when fitted

3.86**tool**

screwdriver, coin or other object that may be used to operate a screw or similar fixing means

3.87**specially prepared cord**

flexible cable or cord the replacement of which with another non-special cable or cord would create a hazard or diminish safety

3.88**settable luminaire**

fixed luminaire, the main part of which can be turned or moved by means of joints, raising and lowering devices, telescopic tubes or similar devices, but which has a locking device (or devices) operated by a tool and is not intended to be adjusted during use

[SOURCE: IEC 60050-845:2020, 845-30-014]

3.89**light source**

surface or object emitting light

Note 1 to entry: A light source can be self-emitting (primary light source) or non-self-emitting (secondary light source).

Note 2 to entry: An electric light source can be an electric lamp, or LED module designed to be connected by terminals, connectors or similar devices.

[SOURCE: IEC 60050-845:2020, 845-27-001, modified – The Note 2 to entry has been replaced by a new Note 2 to entry.]

3.89.1**replaceable light source**

light source designed to be replaced by an ordinary person or a skilled person

Note 1 to entry: When incorporated into a luminaire, a replaceable light source can be classified as replaceable, non-user replaceable or non-replaceable depending on the luminaire design.

Note 2 to entry: All kinds of lamps provided with lamp caps are considered as replaceable light sources.

[SOURCE: IEC 60050-845:2020, 845-27-005, modified – "qualified" has been replaced by "skilled" and the Note 2 to entry has been added.]

3.89.2**non-replaceable light source**

light source designed to be a non-replaceable part of the luminaire

Note 1 to entry: An integral light source is always non-replaceable. A non-replaceable light source is not always an integral light source.

Note 2 to entry: The non-replaceability can be the result of the luminaire design.

[SOURCE: IEC 60050-845:2020, 845-27-006]

3.89.3**non-user replaceable light source**

replaceable light source intended by the manufacturer to be replaced only by a service agent, or a similarly skilled person

Note 1 to entry: When incorporated into a luminaire, a non-user replaceable light source can become classified as non-replaceable depending on the luminaire design.

[SOURCE: IEC 60050-845:2020, 845-27-007]

3.90**skilled person****electrically skilled person**

person with relevant education and experience to enable him or her to perceive risks and to avoid hazards that electricity can create

[SOURCE: IEC 60050-195:2021, 195-04-01]

3.91**ordinary person**

person who is neither a skilled person nor an instructed person

Note 1 to entry: The definition of an "instructed person or electrically instructed person" is: a person adequately advised or supervised by electrically skilled persons to enable him or her to perceive risks and to avoid hazards that electricity can create.

[SOURCE: IEC 60050-195:2021, 195-04-03, modified – The Note 1 to entry has been added.]

3.92**control terminal**

connections, other than power supply terminals to the electronic controlgear, which are used to exchange information with the controlgear

Note 1 to entry: The power supply terminals can also be used to exchange information with the controlgear.

3.93**mains**

AC or DC power distribution system (external to the luminaire) that supplies operating power to the luminaire and whose voltage corresponds to the low-voltage (LV) band excluding the extra-low-voltage (ELV) band

Note 1 to entry: The limits for LV and ELV voltage bands are specified in IEC 61140:2016, Table 1.

[SOURCE: IEC 60664-1:2020, 3.1.2, modified – "mains supply" has been replaced by "mains", "equipment" has been replaced by "luminaire", "and whose voltage corresponds to the low-voltage (LV) band excluding the extra-low-voltage (ELV) band has been added and the Note 1 to entry has been replaced with a new Note 1 to entry.]

3.94**connecting leads****tails**

internal wiring of luminaires intended to be connected to fixed wiring through separate terminals which will be enclosed inside the luminaire or connecting box

3.95**rated value**

value of a quantity used for specification purposes, established under standard test conditions as declared by the manufacturer or responsible vendor

[SOURCE: IEC 62504:2014, 3.33, modified – The Note 1 to entry has been deleted.]

3.96
input power

electrical power consumed by the luminaire

3.97
constant light output function

function where the current passing through a light source is gradually increased through life to compensate for the gradual light output degradation of the light source that can be expected to occur

Note 1 to entry: Constant light output functions can be controlled by a programmed software algorithm based on the expected gradual light output degradation or on feedback from a connected sensor such as a photocell.

3.98
interrupted DC voltage

DC signal changing between zero and a certain level with a certain frequency, where the time of the signal being at the certain level can vary within one period

3.99
PSE
power sourcing equipment

equipment generating power to supply other equipment through information technology communication cabling providing energy source ES1 according to the IEC 62368 series

3.100
PoE
power over Ethernet

powering of a device with a PSE according to IEC 62368-3, via twisted pair Ethernet cabling including the appropriate connectors

Note 1 to entry: Typical examples of cables are CAT 5 cables and CAT 7 cables.

3.101
USB
universal serial bus

communication interface including appropriate connectors for communication and powering devices, according to the IEC 62680 series

Note 1 to entry: A class III luminaire is an example of a device as given in the definition.

Note 2 to entry: Several versions exist (USB 1.0, 2.0, 3.0).

3.102
information technology communication cabling

any cable meant for data transfer, provided with a connector defined by an industry standard that permits DC power transfer between equipment, even if communication does not take place

EXAMPLE USB or Ethernet cables.

3.103
track-mounted luminaire

luminaire designed to be used on a track system, for which the electrical and mechanical connection is ensured either with an adaptor or by a luminaire supply connector together with a luminaire suspension device

Note 1 to entry: Class I and Class II luminaires may be used with Class I track systems or sectors, Class III luminaires can only be used with Class III track systems or sectors.

Note 2 to entry: Track-mounted luminaires can have control interface facilities.

**3.104
pillar terminal**

terminal in which the conductor is inserted in a hole or cavity, where it is clamped under the shank of the screw or screws

Note 1 to entry: The clamping pressure may be applied directly by the shank of the screw or through an intermediate clamping member to which pressure is applied by the shank of the screw.

Note 2 to entry: Examples of pillar terminals are shown in Figure 46.

**3.105
screw terminal**

terminal in which the conductor is clamped under the head of the screw

Note 1 to entry: The clamping pressure may be applied directly by the head of the screw or through an intermediate part, such as a washer, clamping plate or anti-spread device.

Note 2 to entry: Examples of screw terminals are shown in Figure 47.

**3.106
stud terminal**

terminal in which the conductor is clamped under a nut

Note 1 to entry: The clamping pressure may be applied directly by a suitably shaped nut or through an intermediate part, such as a washer, clamping plate or anti-spread device

Note 2 to entry: Examples of stud terminals are shown in Figure 47.

**3.107
saddle terminal**

terminal in which the conductor is clamped under a saddle by means of two or more screws or nuts

Note 1 to entry: Examples of saddle terminals are shown in Figure 48.

**3.108
lug terminal**

screw terminal or stud terminal designed for clamping a cable lug or bar by means of a screw or nut

Note 1 to entry: Examples of lug terminals are shown in Figure 49.

**3.109
mantle terminal**

terminal in which the conductor is clamped against the base of a slot by a suitably shaped washer under the nut, by a central peg if the nut is a cap nut, or by equally effective means for transmitting the pressure from the nut to the conductor within the slot

Note 1 to entry: Examples of mantle terminals are shown in Figure 50.

**3.110
screwless terminal**

part required to make connection in electrical circuits by mechanical means without screws

**3.111
permanent connection**

connection designed to be made only once with the same conductor

EXAMPLE Wire wrapping or crimping.

3.112**non-permanent connection**

connection which allows lead assemblies or conductors to be connected and disconnected several times

EXAMPLE Pin or tab and receptacle, or some spring-type terminals.

3.113**lead assembly**

conductor fitted with auxiliary parts, usually by permanent connection

3.114**non-prepared conductor**

conductor without special preparation or auxiliary parts

Note 1 to entry: Insulation may, however, be stripped to expose the conductor.

Note 2 to entry: The term "special preparation" covers the application of additional solder to the strands of the conductor, use of cable lugs, pins or tabs and receptacles, formation of eyelets, etc., but not the reshaping of the conductor for its introduction into the terminal or the twisting of a stranded conductor to consolidate the end.

The bonding together by heating of the tinned strands of a flexible conductor without the addition of solder is not considered to be special preparation.

3.115**test current**

current assigned to a terminal or connection by the manufacturer

Note 1 to entry: When terminals are part of a component, the test current shall be the rated current of the component.

3.116**battery/EDLC-operated luminaire**

luminaire powered by rechargeable or non-rechargeable batteries or electric double-layer capacitor (EDLC)

3.117**battery**

one or more cells fitted with devices necessary for use, for example case, terminals, marking and protective devices

[SOURCE: IEC 60050-482:2004, 482-01-04]

3.118**cell**

basic functional unit, consisting of an assembly of electrodes, electrolyte, container, terminals and usually separators, that is a source of electric energy obtained by direct conversion of chemical energy

Note 1 to entry: See primary cell and secondary cell.

[SOURCE: IEC 60050-482:2004, 482-01-01]

3.119**replaceable battery**

battery intended to be replaced by the user

3.120

non-replaceable battery/EDLC

battery or EDLC which is a non-replaceable part of the luminaire either because it cannot be replaced without breaking or destroying the luminaire or because it is enclosed under a cover fixed by screw or similar fixing means designed to be used only once and which cannot be opened

3.121

non-user replaceable battery/EDLC

battery or EDLC which can only be replaced by the manufacturer, their service agent, or a similarly skilled person

3.122

button battery

small round battery where the overall height is less than the diameter and having an electrochemical system that does not contain lithium

[SOURCE: IEC 60050-482:2004, 482-02-40, modified – The definition has been adapted to include batteries instead of cells and to differentiate between lithium and non-lithium batteries.]

3.123

coin battery

small round battery where the overall height is less than the diameter and having an electrochemical system that contains lithium

[SOURCE: IEC 60050-482:2004, 482-02-40, modified – The definition has been adapted to include batteries instead of cells and to differentiate between lithium and non-lithium batteries.]

3.124

EDLC

electric double-layer capacitor

capacitor used to perform the function of a battery

3.125

rated capacity

capacity value of a battery determined under specified conditions and declared by the manufacturer

[SOURCE IEC 60050-482:2004, 482-03-15]

3.126

battery/EDLC charger

device to charge batteries or EDLCs

3.127

charging system

circuitry intended to charge and which can balance or maintain the state of charge of the battery

Note 1 to entry: The functional elements of the charging system can be distributed between the charger, any detachable battery, and the luminaire itself.

3.128

detachable battery pack

battery which is contained in a separate enclosure from the battery luminaire and is intended to be removed from the luminaire for charging purposes

3.129**general purpose cell
general purpose battery**

battery and cell available from a variety of manufacturers, through a variety of outlets intended for a variety of different manufacturers' products

EXAMPLE 12-V lead acid automotive style batteries and non-rechargeable AA, C, and D alkaline batteries.

3.130**fully charged**

at the maximum state of charge

Note 1 to entry: For cells and batteries that are rechargeable, this is the maximum state of charge permitted by the charging system.

Note 2 to entry: The maximum state of charge for non-rechargeable batteries and batteries that are rechargeable is specified in the artificial source characteristics of Table W.1.

4 General requirements**4.1 General**

4.1.1 Luminaires shall be so designed and constructed that in normal use they function safely and cause no danger to persons or surroundings. In general, compliance is checked by carrying out all the tests specified.

4.1.2 A luminaire shall comply with a part of the IEC 60598-2 series. If, however, an appropriate part of the IEC 60598-2 series does not exist for a particular luminaire or group of luminaires, the nearest applicable part of the IEC 60598-2 series may be used as a guide to the requirements and tests.

Where the design of a luminaire is such that two or more parts of the IEC 60598-2 series are applicable, the luminaire shall comply with both or all of the appropriate parts.

The parts of the IEC 60598-2 series, in making reference to any of the clauses of this document, specify the extent to which that clause is applicable and the order in which the tests are performed; they also include additional requirements as necessary.

The order in which the clauses of this document are numbered has no particular significance as the order in which their provisions apply is determined for each type of luminaire or group of luminaires by the appropriate part of the IEC 60598-2 series. Each part of the IEC 60598-2 series is self-contained and therefore does not contain references to other parts of the IEC 60598-2 series.

Where the requirements of any of the clauses of this document are referred to in parts of the IEC 60598-2 series by the phrase "The provisions of Section X of Part 1 apply..." or the phrase "This Clause of Part 1 applies...", these phrases are interpreted as meaning that all the requirements of that clause of this document apply except those which are clearly inapplicable to the particular type of luminaire covered by that part of the IEC 60598-2 series.

4.1.3 Where the terms "voltage" and "current" are used, they imply the RMS values unless otherwise stated.

4.2 General test requirements and verification

4.2.1 Tests according to this document are type tests. For the definition of a "type test", see 3.50.

Guidance on conformity testing during manufacturing is given in Annex N.

The requirements and tolerances permitted by this document are related to testing of a type test sample submitted for that purpose. Compliance of the type test sample does not ensure compliance of the whole production of a manufacturer. Compliance for production is the responsibility of the manufacturer and can include routine tests and quality assurance in addition to type testing.

4.2.2 Luminaires shall be evaluated as delivered, and installed as for normal use, in an ambient temperature of between 10 °C and 30 °C, having regard to the manufacturer's installation instructions, except where otherwise specified in this document or the relevant part of the IEC 60598-2 series. Lamps and replaceable light sources are not included except where essential for the test. Non-replaceable light sources and non-user replaceable light sources are components which are essential to demonstrate the compliance with this document.

Requirements in this document are based on overvoltage category II which is considered appropriate for normal application of luminaires covered under the scope of the IEC 60598 series. Annex Q provides a recommendation that would allow luminaires to have a higher overvoltage capability according to overvoltage category III.

Luminaires cannot be regarded as meeting the requirements of this document unless all internal wiring is complete.

In general, the tests are made on a single sample luminaire or, where a range of similar luminaires is involved, on a single luminaire of each rated power in the range or on a representative selection from the range as agreed with the manufacturer (see Annex P). This selection shall include the luminaire, together with any attachments, which represents the most unfavourable combination from a testing point of view.

Each sample luminaire shall comply with all the relevant tests. To reduce the time of testing and to allow for any tests which can be destructive, the manufacturer may submit additional identical luminaires or parts of luminaires of the same materials. Where the test for compliance is shown as being "by inspection", this shall include any necessary handling.

For track-mounted luminaires the manufacturer shall provide, together with the luminaire, a sample of the appropriate track, connector and adaptors for the luminaire to be connected.

Combination luminaires are tested for safety requirements with that assemblage of parts which gives the most unfavourable result.

Certain parts of luminaires, such as joints, raising and lowering devices, may be tested separately provided that the design of these parts is such that their performance is not dependent upon the other parts of the luminaires.

Luminaires intended to be used with supply cords are tested with the flexible supply cord connected to the luminaire.

For luminaires intended to be used with a shade, but not normally supplied with a shade, the manufacturer shall provide a shade, typical of the type that can be used with the luminaire.

Luminaires containing batteries or EDLCs and their accessories (e.g. remote control) shall additionally comply with the requirements given in Annex W.

Annex W is not applicable for emergency lighting luminaires. All battery/EDLC related requirements for emergency lighting luminaires are given in IEC 60598-2-22.

4.2.3 With regard to the verification and tests, luminaires for testing to the requirements of this document can have earlier test reports updated in accordance with this document by submitting a new sample for test, together with the previous test reports.

Full type testing is not generally necessary and the product and the previous test results are reviewed only against any amended clauses listed in Annex O.

4.3 Components of luminaires

4.3.1 Components, other than integral components, shall comply with the requirements of the relevant IEC standards, if any. However, cells and batteries shall be considered in accordance with 4.3.4.

NOTE 1 Examples of components are lampholders, switches, transformers, controlgear, flexible cables and cords and plugs.

Components which comply with the requirements of the relevant IEC standard and marked with individual ratings are checked to establish that they suit the conditions which can occur in use. Aspects of use not covered by the respective standard shall require them to satisfy the additional relevant requirements of this document.

Compliance is checked by inspection and the relevant tests.

Integral components shall comply as far as is reasonable with the IEC component standards, as part of the luminaire.

NOTE 2 This does not imply that components are separately tested before approval of the luminaire.

NOTE 3 Guidance on the selection of components in different kinds of luminaires can be found in Annex J.

Internal wiring of a luminaire shall comply with the requirements in 8.3.

NOTE 4 This does not exclude the use of standardized cables.

4.3.2 Components complying with the requirements of their own standard and used in accordance with their intended use, shall only be tested to the requirements of this document where there are no requirements in the component standard (covering the requirement heading of this document).

A valid test report is considered adequate to show compliance.

For terminal blocks with integrated screwless protective earthing contacts for direct connection to the luminaire or to parts of the body, special requirements apply according to Annex R.

4.3.3 Components for which no appropriate IEC standard exists shall satisfy the relevant requirements of this document as part of the luminaire. Lampholders and starterholders shall additionally comply with the gauging and interchangeability requirements of the appropriate IEC component standard where applicable.

4.3.4 Batteries/EDLCs for luminaires shall comply with IEC standards as follows:

- Batteries comprising Li-ion cells are not required to comply with IEC 62133-2. They are tested as part of the luminaire according to this document.
- Li-ion cells are required to comply with IEC 62133-2.
- Cells and batteries of other technologies than Li-ion are not required to comply with IEC 62133-1 nor IEC 62133-2. They are tested as part of the luminaire according to this document.
- EDLCs are required to comply with IEC 62391-1 and IEC 62391-2.

4.4 Information for luminaire design in light sources and controlgear standards

4.4.1 In accordance with IEC guidelines, IEC standards are divided into those covering either safety or performance.

4.4.2 In light source and controlgear safety standards, "information for luminaire design" is given for the safe operation of light sources or controlgear; this shall be regarded as normative when testing luminaires in accordance with this document.

4.4.3 In light source and controlgear performance standards, "information for luminaire design" is given for the correct performance of light sources or controlgear; this shall be regarded as informative when testing luminaires in accordance with this document. Testing of light source or controlgear performance is not required as part of the type test approval for luminaires.

5 Classification of luminaires

5.1 General

Luminaires are classified according to the type of protection against electric shock, the degree of protection against ingress of dust, solid objects and moisture, the material of the mounting surface and the circumstances of use.

5.2 Classification according to the type of protection against electric shock

Luminaires shall be classified according to the type of protection against electric shock provided, as class I, class II or class III (see definitions 3.24, 3.25 and 3.26).

Luminaires shall have only a single classification. For instance, for a luminaire with a built-in component such as an extra-low-voltage transformer with provision for protective earthing, the luminaire shall be classified as class I and no part of the luminaire shall be classified as class III even though the lamp compartment is separated by a barrier from the transformer compartment.

Semi-luminaires shall comply with all relevant requirements for class II luminaires without being provided with the class II symbol.

NOTE 1 Unless a luminaire has been specifically designed for use with semi-luminaires, the luminaire manufacturer is not responsible for continued conformity with the IEC 60598 series in the situation where the user has replaced specified lamp types with semi-luminaires. The semi-luminaire manufacturer is responsible for providing information with respect to limitations of use.

NOTE 2 The class II symbol is omitted in order to avoid the symbol being applied to the complete luminaire in which the semi-luminaire is used.

5.3 Classification according to the degree of protection against ingress of dust, solid objects and moisture

Luminaires shall be classified in accordance with the "IP number" system of classification described in IEC 60529.

Tests for the degrees of protection are given in Clause 11.

NOTE Luminaires classified as watertight are not necessarily suitable for operation under water. Pressure watertight luminaires can be used for such applications.

5.4 Classification according to the material of the mounting surface for which the luminaire is designed

Luminaires shall be classified according to whether they are suitable for direct mounting on normally flammable surfaces or are only suitable for mounting on non-combustible surfaces as follows:

Classification	Symbol
– Luminaires suitable for direct mounting on normally flammable surfaces	No symbol required
– Luminaires not suitable for direct mounting on normally flammable surfaces (suitable only for mounting on non-combustible surfaces)	Relevant symbols (See Figure 9)

NOTE Readily flammable surfaces are not suitable for the direct mounting of luminaires. Requirements for luminaires classified as primarily intended for direct mounting on normally flammable surfaces are given in Clause 7 and related tests in Clause 14.

5.5 Classification according to the circumstances of use

Luminaires shall be classified according to whether they are intended for normal use or for rough service.

Classification	Symbol
– Luminaires for normal use	No symbol
– Luminaires for rough service	Symbol (See Figure 16)

6 Marking

6.1 General

Any written instructions related to safety shall be in a language which is acceptable in the country in which the equipment is to be installed.

6.2 Marking on luminaires

The following information shall be distinctly and durably marked on the luminaire (see Table 1). Each marking in Table 1 shall be read with the corresponding subclause as detailed in the table.

- a) Marking to be observed when replacing lamps or other replaceable components shall be visible on the outside of the luminaire (except the mounting side) or behind a cover which is removed during lamp or other component replacement and with the lamp removed.
- b) Marking to be observed during installation shall be visible during installation on the outside of the luminaire or behind a cover or part which is removed during installation.
- c) Marking to be observed after installation shall be visible with the luminaire assembled and installed as for normal use and with the lamp in place.

Marking may be on controlgear provided the conditions under a) or b) above, as appropriate, are fulfilled. See Table 1 for details.

Table 1 – Marking

Markings belonging to 6.2, item a)	Markings belonging to 6.2, item b)	Markings belonging to 6.2, item c)
6.3.8 a) and c) ^a Rated power	6.3.1 to 6.3.2 ^b	6.3.13 Lighted objects ^d
6.3.10 Special lamps	6.3.3 Ambient temperature	6.3.14 Rough service
6.3.11 Cool beam	6.3.4 to 6.3.5	6.3.20 Means of adjustment
6.3.15 Bowl mirror	6.3.6 IP number	6.3.22 Do not stare at light source ^e
6.3.16 Protective shield	6.3.7 Type reference	6.3.27 Rated current of the mains socket outlet
6.3.18 Ignition warning	6.3.8 b) Rated input power	
6.3.19 Self-shielded lamp	6.3.9 Symbols	
6.3.21 Internal replaceable fuse(s)	Relevant symbol for luminaires not suitable for direct mounting on normally flammable surfaces	
6.3.22 Do not stare at light source ^e	6.3.12 Termination	
6.3.23 Symbol for electric shock risk	6.3.17 ^c Interconnected luminaires	
6.3.26 Rated electrical output characteristics ^h	6.3.24 Rated input constant voltage ^f	
	6.3.25 Rated input constant current and value of U_{out} ^g	
	6.3.26 Rated electrical output characteristics ^h	

^a 6.3.8 c) Rated power. For luminaires for discharge lamps with remote controlgear, the marking may be replaced by the instruction: "For lamp designation, see controlgear".

^b 6.3.2 Rated voltage. For luminaires for discharge lamps, if the ballast is not built into the luminaire, the luminaire shall be marked with the working voltage instead of the mains voltage.

^c 6.3.17 Interconnected luminaires. For fixed luminaires, this information may alternatively be provided within the installation instructions.

^d 6.3.13 Lighted objects. Only the symbol shall be provided on the luminaire. The explanation of the symbol shall be provided in the instruction accompanying the luminaire, where not already provided on the luminaire.

^e 6.3.22 The different conditions of this marking for fixed, portable and handheld luminaires are given in 6.3.22.

^f 6.3.24 For constant voltage operation of the luminaire.

^g 6.3.25 For constant current operation of the luminaire.

^h 6.3.26 The different conditions of this marking for luminaires with built-in or external independent controlgear are given in 6.3.26.

The earthing symbol referred to in 6.3.12 may be marked on the controlgear, instead of the luminaire, if the controlgear is of a non-replaceable type. The height of graphical symbols shall not be less than 5 mm, except for symbols for class II and class III classification which may be reduced to a minimum of 3 mm where the space available for marking is restricted. The height of letters and numerals either shown separately or with or as part of symbols shall not be less than 2 mm.

For luminaires marketed as combination of different parts (e.g. light source enclosure and controlgear enclosure) where the type references or the rated inputs are different for different combinations, the main part and the alternative parts may be marked with a type reference or a rated input, as appropriate, provided that the type can be identified and the rated input of the complete unit may be established from a catalogue or a similar document.

For luminaires with electro-mechanical contact systems, the base plate shall be marked with the rated current of the electrical connection if the system can be used with a variety of different luminaire types.

6.3 Information to be marked on luminaires

6.3.1 Mark of origin (this may take the form of a trademark, the manufacturer's identification mark or the name of the responsible vendor).

6.3.2 Rated voltage(s) in volts and nature of supply

For the nature of supply, it shall be one of following markings:

- with the symbol for nature of supply (see Figure 4, Figure 5 or Figure 6),
- by the abbreviation DC or AC,
- by the marking of the rated frequency or rated frequencies, or
- as detailed in Table 3 for leads and terminations used for the connection to extra-low-voltage DC supplies.

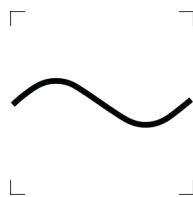

(IEC 60417-5032:2002-10)

Figure 4 – AC supply

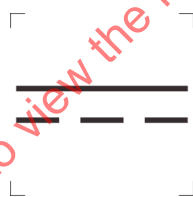

(IEC 60417-5031:2002-10)

Figure 5 – DC supply

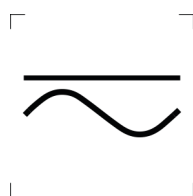

(IEC 60417-5033:2002-10)

Figure 6 – DC and AC supply

The marking for the nature of supply can be avoided where the supply can be both AC supply and DC supply, but if marked, Figure 6 shall be used.

Portable class III luminaires shall be marked with the rated voltage on the outside of the luminaire.

Luminaires with built-in transformers or convertors shall be marked with the nominal voltage or current of the light source, or both, to ensure correct replacement. This marking shall be positioned in accordance with 6.3.8.

Where marking is provided in accordance with 6.3.24 or 6.3.25, additional marking of the rated voltage is not required.

Luminaires supplied via an external PSE shall have a marked rated voltage, which is within the voltage range of the values given in Table U.2, for the chosen communication cables or connectors.

6.3.3 Rated maximum ambient temperature t_a , if other than 25 °C as follows:

$$t_{a...} \text{ °C}$$

6.3.4 Symbol for class II luminaires where applicable (see Figure 7).

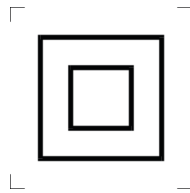

(IEC 60417-5172:2003-02)

Figure 7 – Class II

For portable luminaires provided with a supply cord, the symbol for class II construction, if applicable, shall be on the outside of the luminaire.

The class II symbol shall not be applied to semi-luminaires.

6.3.5 Symbol for class III luminaires where applicable (see Figure 8). This symbol is not required for class III battery/EDLC-operated luminaires supplied exclusively by batteries/EDLCs and which are not designed to be connected to any charger power supply.



(IEC 60417-5180:2003-02)

Figure 8 – Class III

6.3.6 Marking (if applicable) with IP numbers for the degree of protection against ingress of dust, solid objects and moisture (see Table 2 and Annex H). Where X is used in an IP number in Table 2, it indicates a missing numeral in the example, but both of the appropriate numerals shall be marked on the luminaire.

Table 2 – IP numbers for degree of protection against ingress of dust, solid objects and moisture

Ordinary	IP20
Drip-proof	IPX1
Drip-proof (15°)	IPX2
Rain-proof	IPX3
Splash-proof	IPX4
Jet-proof	IPX5
Powerful water jet-proof	IPX6
Watertight (immersible)	IPX7
Pressure-watertight (submersible)	IPX8 m (followed by an indication of the maximum depth of submersion in metres)
High pressure and temperature water jet-proof	IPX9 (80 °C)
High pressure and cold water jet-proof	IPX9 (15 °C)
Protected against solid objects greater than 2,5 mm	IP3X
Protected against solid objects greater than 1 mm	IP4X
Dust-proof	IP5X
Dust-tight	IP6X

In cases where different IP numbers apply to distinct parts of the luminaire, the lower number shall be marked on the type label on the luminaire, even if IP20, whereas the higher number shall be marked separately on the part concerned. In cases where shades or similar devices for upgrading are used, for example an IP20 luminaire to a higher IP rating when mounted, the IP20 marking shall be made invisible by the device in question without destroying the marking and the device shall visibly be provided with a new IP rating. The instruction sheet supplied with the luminaire shall include details of the IP numbers applying to the various parts of the luminaire. The use of different IP numbers on different parts of a luminaire or devices, to upgrade the IP rating, for example to a higher IP rating, is only applicable to fixed luminaires.

Marking of IP20 on ordinary luminaires is not required.

6.3.7 Maker's model number or type reference.

6.3.8 Luminaires shall be marked with information for the maximum rated light source power or maximum input power according to a), b), or c).

a) Luminaires for tungsten filament lamps shall be marked with the maximum rated power and number of lamps.

Marking of maximum rated power for luminaires for tungsten filament lamps with more than one lampholder may be in the form:

" $n \times \text{MAX... W}$ ", n being the number of lampholders.

b) Luminaires designed for non-replaceable or non-user replaceable light sources shall be marked with the rated input power of the luminaire.

Rated input power marking is not required for class III battery/EDLC-operated luminaires supplied exclusively by batteries/EDLCs and which are not designed to be connected to any charger power supply.

NOTE The intention of the marking with the rated input power is to give guidance to installers. This document does not specify a test for the input power.

c) For all other luminaires, rated power of the lamp or the designation as indicated on the lamp data sheet of the type or types of lamp for which the luminaire is designed. Where the lamp power alone is insufficient, the number of lamps and the type shall also be given.

6.3.9 Where applicable, symbol (see Figure 9) for luminaires not suitable for direct mounting on normally flammable surfaces. The symbol shall be explained on the luminaire or in the manufacturer's instructions provided with the luminaire. See Table L.1. The minimum size of the symbol shall be 25 mm for each side.



Figure 9 – Luminaire not suitable for direct mounting on normally flammable surfaces

6.3.10 Information concerning special lamps, if applicable.

In particular, this applies to the symbols (see Figure 10 and Figure 11) for luminaires for use with high-pressure sodium lamps having either an internal starting device or requiring an external ignitor where the lamp is required to be marked with the same symbol according to IEC 60662.



(SOURCE: IEC 60662)

Figure 10 – High-pressure sodium lamps that require an external ignitor (to the lamp)



(SOURCE: IEC 60662)

Figure 11 – High-pressure sodium lamps having an internal starting device

6.3.11 Symbol (see Figure 12), if applicable, for luminaires for lamps of similar shape to "cool beam" lamps but where the use of a dichroic reflectorized "cool beam" lamp can impair safety.

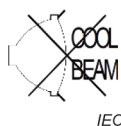
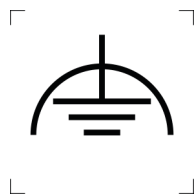

Figure 12 – Warning against the use of cool-beam lamps

6.3.12 Except for type Z attachments, terminations shall be marked to identify live, neutral and earth in case of connection of the luminaire to the supply mains to ensure safe and satisfactory operation.

Symbols, when applied, indicating mains supply terminations shall be according to IEC 60417.

The earthing termination shall be marked by the relevant symbol of IEC 60417 only (see Figure 13 and Figure 14).



(IEC 60417-5018:2011-07)

Figure 13 – Functional earthing

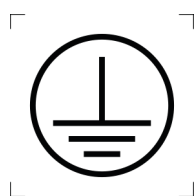

(IEC 60417-5019:2006-08)

Figure 14 – Protective earthing

Where terminals are provided in a Class II luminaire for the continuity or termination of a protective earth conductor, such terminals shall be marked with the letter E.

NOTE 1 Examples of such terminals are those used for looping or through wiring.

Leads (tails) and terminations used for the connection to extra-low voltage DC supplies shall indicate their intended connection choosing one of the below mentioned combination (see Table 3):

Table 3 – Identification of extra-low-voltage DC leads and terminations

Positive	Negative
"+"	"-"
Colour coded red ^a	Colour coded black ^a
^a Use of labels or sleeving fixed to the leads to give one of the above identification is acceptable.	

NOTE 2 Terminations can be found at leads (tails), connection or terminal blocks and terminals of another construction.

Luminaires with supply cords which are not fitted with a plug shall include with the manufacturer's instructions information necessary to ensure safe connection, for example deviations from the national standardized colour coding of the cores where this does not create the possibility of an unsafe situation during installation, use or maintenance.

NOTE 3 In some countries, luminaires with supply cords which are intended to be connected to the supply via a socket-outlet and which are not fitted with a plug are not permitted.

6.3.13 Symbol (see Figure 15) for minimum distance from lighted objects, if applicable, for luminaires which can otherwise overheat the lighted objects due to, for example, the applied lamp type, the shape of the reflector, the adjustability of the mounting means or the location of mounting as indicated in the installation instructions.

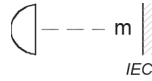

Figure 15 – Minimum distance from lighted objects (metres)

The minimum distance marked shall be determined by the temperature test described in 14.4.2, item j).

The distance is measured on the optical axis of the luminaire from that part of the luminaire or lamp which is nearest to the lighted object.

The symbol for minimum distance and explanation of its meaning shall also be given either on the luminaire or in the instructions with the luminaire.

6.3.14 Symbol (see Figure 16), if applicable, for rough service luminaires.

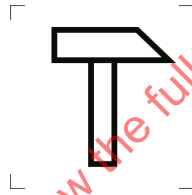

(IEC 60417-6034:2010-04)

Figure 16 – Rough service

6.3.15 Symbol (see Figure 17), if applicable, for luminaires which are designed for use with bowl mirror lamps.

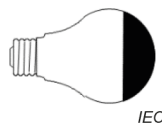

Figure 17 – Bowl mirror lamp

NOTE Separate bowls for attachment to GLS lamps without reference to luminaire testing are not within the scope of this document.

6.3.16 Luminaires incorporating a protective shield shall be marked either with:

- "Replace any cracked protective shield", or
- the relevant symbol (see Figure 18).

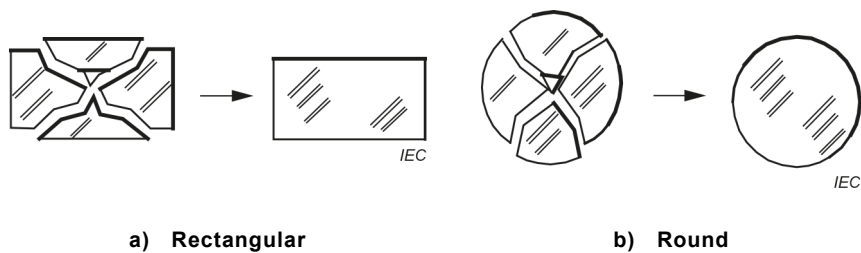
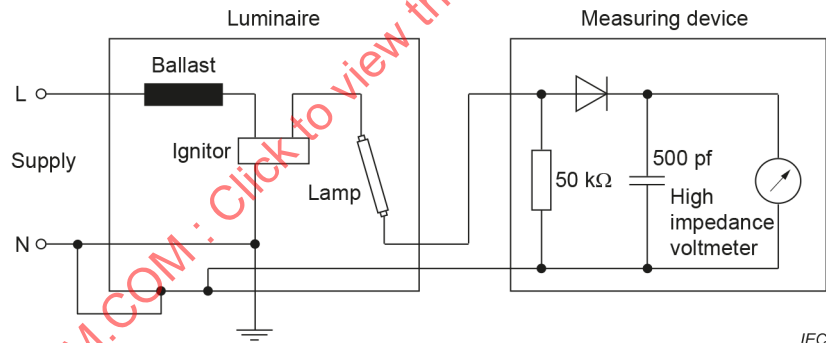

Figure 18 – Replace any cracked protective shield

6.3.17 The maximum number of luminaires that may be interconnected or the maximum total current that may be drawn by means of couplers provided for looping-in connection to the mains supply. For fixed luminaires, this information may alternatively be provided within the installation instructions.

6.3.18 A warning symbol or notice for luminaires with ignitors intended for use with double-ended high pressure discharge lamps and luminaires with double-capped Fa8 tubular lamps if the voltage measured according to Figure 19 exceeds 34 V peak:

- warning symbol in accordance with IEC 60417-5036:2002-10 visible during replacement of the lamp. The symbol shall be explained on the luminaire or in the manufacturer's instructions provided with the luminaire, or
- a warning notice near to the holder of a replaceable ignitor or replaceable switching element, if any: "Attention, remove replaceable device before replacement of lamp. After lamp replacement reinsert replaceable device".



After the first measurement, the polarity of the diode shall be reversed and the test repeated.

Figure 19 – Test circuit for safety during insertion

6.3.19 Symbol (see Figure 20) for luminaires which are designed to be used only with self-shielded tungsten-halogen lamps or self-shielded metal halide lamps.

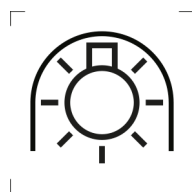

(IEC 60417-6030:2009-11)

Figure 20 – Self-shielded lamp

6.3.20 Where necessary, the means of adjustment, where not obvious, shall be identified.

NOTE Appropriate marking includes symbols (e.g. arrows) to indicate the direction of movement, descriptive text or colours.

6.3.21 Symbol (see Figure 21) if applicable, for luminaires with internal replaceable fuses. Such a luminaire shall, in addition, be provided with information regarding the rated current (in A or mA) of the fuse. Where the time-current characteristic of the fuse is important for safety, the rating and type of every fuse shall be marked on the holder or in the proximity of the fuse in accordance with what is stated in the relevant fuse standard.

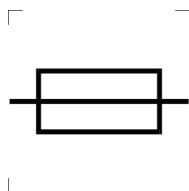

(IEC 60417-5016:2002-10)

Figure 21 – Luminaires with internal fuses

6.3.22 For blue light hazard, luminaires assessed according to IEC 62471-7:2023 shall comply with 6.3.22 a) and luminaires assessed according to IEC TR 62778:2014² shall comply with 6.3.22 b).

NOTE 1 It is the intention in the future edition of this document to remove 6.3.22 b) as IEC 62471-7 completely replaces IEC TR 62778. In the interim 6.3.22 a) or 6.3.22 b) can be used depending on how the luminaire has been assessed according to 7.24.3.

a) Information on the retinal blue light hazard of luminaires evaluated according to IEC 62471-7: 2023

For fixed luminaires with an increased assessment distance x according to 7.24.3.2, the manufacturer's instructions provided with the luminaire shall include the following text:

"The luminaire shall be positioned so that prolonged staring into the luminaire at a distance of less than x m is not expected".

NOTE 2 Prolonged staring is not expected due to the natural aversion response to bright light sources. Momentary exposure is not considered as prolonged staring.

b) Information on the retinal blue light hazard of luminaires evaluated according to IEC TR 62778:2014

Warning symbol "Do not stare at the operating light source" (see Figure 22) for portable and handheld luminaires that have been classified as having a threshold illuminance E_{thr} in accordance with IEC TR 62778. This marking shall be visible as detailed by condition "c" of 6.2 and Table 1. In addition, the symbol should be positioned so that it can be read without looking into the operating light source. This requirement is applicable only when E_{thr} is reached at a distance further than 200 mm from the luminaire.



Figure 22 – Do not stare at the operating light source

² Withdrawn.

For fixed luminaires that have been classified as having a threshold illuminance E_{thr} in accordance with IEC TR 62778, the manufacturer's instructions provided with the luminaire shall give the following text, where x m is the distance at which the threshold illuminance E_{thr} condition occurs. This requirement is applicable only when E_{thr} is reached at a distance further than 200 mm from the luminaire.

"The luminaire should be positioned so that prolonged staring into the luminaire at a distance closer than x m is not expected".

NOTE 3 According to IEC TR 62778, x m is the distance d_{thr} between the light source and the eyes of the viewer and it is calculated from the lighting distribution measurement of the luminaire.

NOTE 4 Prolonged staring is not expected due to the natural aversion response to bright light sources. Momentary exposure is not considered as prolonged staring.

NOTE 5 According to IEC 62471:2006, 6.1.3, "the philosophical basis for the Risk Group 2 (Moderate-Risk) classification is that the lamp does not pose a hazard due to the aversion response to very bright light sources (...)".

NOTE 6 The above marking requirements have been established following IEC TR 62471-2:2009³.

In addition, luminaires incorporating replaceable or non-user replaceable light sources that have been classified as having a threshold illuminance E_{thr} condition in accordance with IEC TR 62778 and which are directly visible during luminaire maintenance shall be marked with the warning symbol "Do not stare at the operating light source" (see Figure 22). This marking shall be visible as detailed by conditions "a" of 6.2 and Table 1.

6.3.23 Where required for protection against electric shock, covers fixed over non-user replaceable light sources and non-user serviceable components shall be marked with the "caution, risk of electric shock" symbol given in Figure 23. The minimum height of this symbol shall be 15 mm.

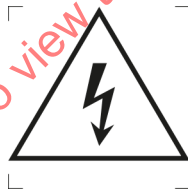

(IEC 60417-6042:2010-11)

Figure 23 – Caution, risk of electric shock

6.3.24 Rated constant input voltage when a luminaire is operated from a constant voltage controlgear not provided with the luminaire.

6.3.25 Rated constant input current when the luminaire is operated from a constant current controlgear not provided with the luminaire. Luminaires supplied with constant current shall also be marked with the highest allowed U_{out} value of the controlgear.

³ Withdrawn.

6.3.26 For luminaires operating a LED light source and containing built-in controlgear, the maximum rated electrical output characteristics from each controlgear (e.g. current for constant current controlgear), for which the luminaire has been designed, shall be marked as required in the first column of Table 1 belonging to item a). For luminaires using external independent controlgear delivered with the luminaire, this marking shall be visible according to the second column of Table 1 belonging to item b). This requirement does not apply:

- to luminaires operating a LED light source and having controlgear provided with the luminaire with fixed output value (single value) as such controlgear are already marked with the output value;
- to controlgear provided with the luminaire where there is no possibility for a change of the setting by the user.

NOTE In the case of a defect in the controlgear, a correct replacement is expected with the delivery from the luminaire manufacturer on request.

For luminaires incorporating a constant light output function, this marking shall indicate the maximum operating conditions for which the luminaire has been designed.

6.3.27 The rated current shall be marked close to the socket outlet for any mains socket-outlet incorporated in the luminaire, if less than the rated value of the socket outlet.

6.4 Additional information

6.4.1 In addition to the marking specified in 6.3, all details which are necessary to ensure proper installation, use and maintenance shall be given either on the luminaire, semi-luminaire or on built-in controlgear or in the manufacturer's instructions provided with the luminaire for instance.

NOTE The list of items provided in 6.4.2 to 6.4.24 is not an exhaustive list.

6.4.2 For combination luminaires, the permissible ambient temperature, the class of protection or the protection against ingress of dust, solid objects and moisture of an alternative part if not at least equal to that of the basic luminaire.

6.4.3 Rated frequency or rated frequencies in hertz.

6.4.4 Operating temperatures:

- a) The rated maximum operating temperature (of a winding) t_w in degrees Celsius.
- b) The rated maximum operating temperature (of a capacitor) t_c in degrees Celsius.
- c) The maximum temperature to which the insulation of supply cables and interconnecting cables will be subjected within the luminaire under the most unfavourable conditions of normal operation, if in excess of 90 °C (see footnote "c" to Table 22 relating to unsleeved fixed wiring). The symbol to indicate this requirement is given in Figure 24.

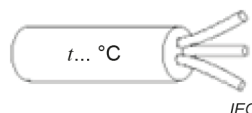

The number of cores shown is optional.

Figure 24 – Use of heat resistant supply cables, interconnecting cables or external wiring

- d) Spacing requirements to be observed during installation.

6.4.5 A wiring diagram, except where the luminaire is suitable for direct connection to the mains supply.

6.4.6 Special conditions for which the luminaire, including the controlgear, is suitable, for instance, whether or not the luminaire is intended for looping-in.

6.4.7 Luminaires provided with metal halide lamps requiring protective shield shall be provided with the following warning notice:

"The luminaire shall only be used complete with its protective shield".

6.4.8 The manufacturer of semi-luminaires shall supply information on the limitations of use of such devices, particularly where overheating can be caused by the position or thermal distribution of the replaceable light source being different from the light sources they will replace.

6.4.9 The manufacturer shall be prepared to supply information on the power factor and the supply current.

For connections suitable for both resistive and inductive loads, the rated current for the inductive load shall be indicated between brackets and shall immediately follow the rated current for the resistive load. The marking may accordingly be as follows:

3(1)A 250 V or 3(1)/250 or $\frac{3(1)}{250}$

The rated current values do not apply to circuits in general but only to the rating of the luminaire as a whole.

6.4.10 For luminaires using remote controlgear, the range of lamps for which the luminaire is designed.

6.4.11 For clip-mounted luminaires, a warning when the luminaire is not suitable for mounting on tubular material.

6.4.12 The manufacturer shall provide the specifications of all protective shields.

6.4.13 The information about rough service luminaires concerning:

- the connection to IPX4 rated socket-outlets;
- the correct mounting taking into account the temporary installation;
- the correct fixing to a stand, and also where the stand is not supplied with the luminaire, the maximum height of a possible stand, and its required stability by the indication of the number and minimum length of the legs.

6.4.14 For luminaires with types X, Y or Z attachments, the mounting instructions shall contain the substance of the following information.

- For type X attachments having a specially prepared cord:
if the external flexible cable or cord of this luminaire is damaged, it shall be replaced by a cord of the same type and having the same preparation.
- For type Y attachments:
if the external flexible cable or cord of this luminaire is damaged, it shall be replaced by the manufacturer or their service agent or a skilled person.
- For type Z attachments:
the external flexible cable or cord of this luminaire cannot be replaced; if the cord is damaged, the whole luminaire shall be replaced.

6.4.15 Luminaires which are other than ordinary, but suitable for indoor use only (e.g. if provided with a PVC supply cord), shall be provided with information about the intended use, i.e. "For indoor use only".

6.4.16 For Class I luminaires having a supply current > 20 A, and which generate a protective conductor current greater than 10 mA and intended for permanent connection, the following shall be clearly stated in the manufacturers' instructions:

- the value of the protective conductor current and
- an indication that the connection to earth shall be according to the wiring rules which can require reinforced protective conductors.

NOTE 1 The requirements for reinforced protective conductors in installation are provided in IEC 60364-5-54:2011, 543.7.

NOTE 2 In Australia and New Zealand there is no allowance for protective conductor current greater than 10 mA.

6.4.17 Wall-mounted, settable and adjustable luminaires not intended to be mounted within arm's reach shall be provided with information to advise their correct installation, i.e. "Only to be installed outside arm's reach".

6.4.18 For luminaires with non-replaceable and non-user replaceable light sources, the manufacturer's instructions shall contain the substance of the following information:

- For non-replaceable light sources:

"The light source of this luminaire is not replaceable; when the light source reaches its end of life the whole luminaire shall be replaced".

As an alternative to text, the pictogram in Figure 25 may be used for marking on the product or on the packaging and shall be explained in the manufacturer's instructions provided with the luminaire or via a link in the instructions to the location of this information in the manufacturer's website.

NOTE 1 The use of a QR code or similar link can be appropriate for this requirement.



NOTE This pictogram is based on the following symbols: ISO 7000-2795:2006-08 (modified) and IEC 60417-5012:2002-10.

Figure 25 – Pictogram for non-replaceable light source

- For non-user replaceable light sources:

"The light source contained in this luminaire shall only be replaced by the manufacturer or their service agent or a skilled person".

As an alternative to text, the pictogram in Figure 26 may be used for marking on the product or on the packaging and shall be explained in the manufacturer's instructions provided with the luminaire or via a link in the instructions to the location of this information in the manufacturer's website.

NOTE 2 The use of a QR code or similar link can be appropriate for this requirement.

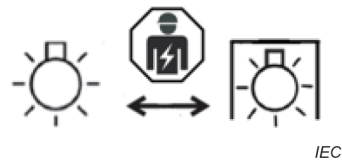

NOTE This pictogram is based on the following symbols: IEC 60417-6182:2013-09 and IEC 60417-5012:2002-10.

Figure 26 – Pictogram for non-user replaceable light source

- For replaceable light sources, the user replaceability of the light source can be indicated by using the pictogram in Figure 27.

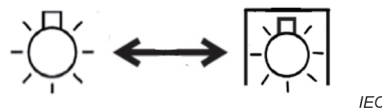

NOTE This pictogram is based on the following symbol: IEC 60417-5012:2002-10.

Figure 27 – Pictogram for replaceable light source

NOTE 3 The use of the pictograms for replaceable light sources is optional. There is no mandatory requirement given by this document for the provision of this particular information.

6.4.19 For luminaires having control terminals for the purpose of controlgear information exchange or setting of controlgear functions, the classification of insulation that has been maintained between mains supply and control conductors shall be provided (e.g. basic insulation, reinforced insulation).

NOTE Maintenance of the declared insulation barrier for the luminaire can also be dependent on other external components or products connected to the same control bus.

6.4.20 Luminaires delivered without controlgear shall be provided with the necessary information for the selection of the appropriate component (in particular the maximum wiring distance and size between controlgear and luminaire), together with the highest allowed U_{out} value of the controlgear and the maximum U_p or equivalent transformed peak voltage U_p where pulse voltages are used. In addition, the classification of insulation of the external controlgear that has been maintained between mains supply and secondary output shall be provided if there is a need for at least basic insulation.

- For luminaires that require no insulation between mains supply and output of the external controlgear no additional information is required.
- For luminaires that require basic insulation between the primary and secondary circuits of the controlgear, the substance of the following information is required:
"External controlgear shall provide at least basic insulation between mains supply and output."
- For luminaires that are not classified as Class III but require double or reinforced insulation between the primary and secondary circuits of the controlgear, the substance of the following information is required:
"External controlgear shall provide at least double or reinforced insulation between mains supply and output."
- For luminaires that are classified as Class III, an indication that the controlgear shall be SELV/PELV is required, except where exposed parts have a voltage higher than 12 V AC or 30 V DC, where an indication that the controlgear shall be SELV only is required.

6.4.21 Where the terminal block is not supplied with the luminaire, the packaging or the instruction sheet shall contain the following wording:

"Terminal block not included. Installation must be performed by a skilled person."

6.4.22 Luminaire manufacturers shall provide information about the protection for on-site mains wiring for luminaires employing light sources that emit UV on the mains wiring insulation. The information shall contain the substance of the following:

"For installation, the use of additional UV resistant sleeves is required for on-site mains supply cables which are not UV resistant (in particular some halogen-free low smoke cable)."

NOTE It is not expected that light sources for general lighting other than fluorescent, metal halide, high pressure mercury lamps will emit levels of UV that can damage the insulation of the cables.

6.4.23 For fixed wall-mounted and portable wall-mounted luminaires using an external flexible cable or cord longer than 30 cm, the manufacturer's instructions shall include the substance of the following wording: "To reduce the risk of strangulation the flexible wiring connected to this luminaire shall be effectively fixed to the wall if the wiring is within arm's reach".

6.4.24 Luminaires shall be provided with information regarding the manufacturer's instructions for the replacement or non-replacement of the controlgear of the luminaire and any associated servicing or operational adjustment of these parts.

Luminaires having controlgear shall be provided with the following information as applicable:

a) Non-serviceable controlgear:

For luminaires where the controlgear is a non-replaceable part the following information shall be given: "The controlgear of this luminaire is a non-replaceable component; when the controlgear reaches its end of life the whole luminaire shall be replaced."

As an alternative to text, the pictogram in Figure 28 may be used for marking on the product or on the packaging and shall be explained in the manufacturer's instructions provided with the luminaire or via a link in the instructions to the location of this information in the manufacturer's website.

NOTE 1 The use of a QR code or similar link can be appropriate for this requirement

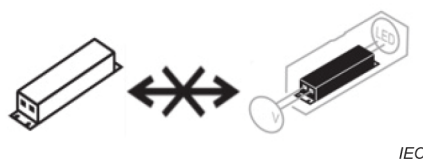

NOTE This pictogram is based on the following symbol: ISO 7000-2795:2006-08 (modified).

Figure 28 – Pictogram for non-replaceable controlgear

Additionally for luminaires where access to the controlgear (e.g. for adjustment of operating parameters) is to be prevented, the following information shall be given: "The controlgear of this luminaire is a non-serviceable component, do not attempt to gain access to the controlgear."

b) Non-user serviceable controlgear:

For luminaires where the controlgear is a non-user replaceable part the following information shall be given: "The servicing of the controlgear in this luminaire should only be undertaken by the manufacturer or their service agent or a similarly skilled person".

As an alternative to text, the pictogram in Figure 29 may be used for marking on the product or on the packaging and shall be explained in the manufacturer's instructions provided with the luminaire or via a link in the instructions to the location of this information in the manufacturer's website.

NOTE 2 The use of a QR code or similar link can be appropriate for this requirement.



IEC

NOTE This pictogram is based on the following symbol: IEC 60417-6182:2013-09.

Figure 29 – Pictogram for non-user replaceable controlgear

Additionally for luminaires where user access to the controlgear (e.g. for adjustment of operating parameters) is to be prevented, the following information shall be given: "The controlgear of this luminaire is a non-user serviceable component, access to the controlgear is only to be undertaken by the manufacturer or their service agent or a similarly skilled person".

c) Serviceable controlgear:

For luminaires where the controlgear is a replaceable part that may be replaced by the user of the luminaire the following information shall be given: "The controlgear in this luminaire may be replaced in accordance with the recommendations given by the luminaire manufacturer".

NOTE 3 The luminaire manufacturer can include, on request, the type reference of the components that are suitable for servicing the luminaire.

As an alternative to text, the pictogram in Figure 30 may be used for marking on the product or on the packaging and shall be explained in the manufacturer's instructions provided with the luminaire or via a link in the instructions to the location of this information in the manufacturer's website.

NOTE 4 The use of a QR code or similar link can be appropriate for this requirement.



IEC

Figure 30 – Pictogram for replaceable controlgear

Additionally for luminaires where user access to the controlgear (e.g. for adjustment of operating parameters) is permitted, instructions for the setting or adjustment of the controlgear shall be provided.

6.5 Test of marking

Compliance with the requirements of 6.2, 6.3 and 6.4 is checked by inspection and by the following test.

The durability of the marking is checked by trying to remove it by rubbing lightly for 15 s with a piece of cloth soaked with water and, after drying, for a further 15 s with a piece of cloth soaked with petroleum spirit and by inspection after the tests detailed in Clause 14 have been completed.

After the test, the marking shall be legible, marking labels shall not be easily removable and they shall show no curling.

NOTE The petroleum spirit used typically consists of a solvent hexane with a content of aromatics of maximum 0,1 % by volume, a value of 29 % for kauri-butanol, an initial boiling-point of approximately 65 °C, a dry-point of approximately 69 °C and a density of approximately 0,68 g/cm³.

7 Construction

7.1 General

Clause 7 specifies general constructional requirements for luminaires. See also Annex J.

7.2 Replaceable components

Luminaires incorporating components or parts intended to be replaceable or serviceable shall be so designed that there is sufficient space to permit replacement or service of such components or parts without difficulty and without impairing safety.

Compliance is checked by inspection and by the replacement of the components.

NOTE Sealed-in components and riveted parts are not replaceable components.

7.3 Wireways

Wireways shall be smooth and free from sharp edges, burrs, flashes and the like, which can cause abrasion of the insulation of the wiring. Parts such as metal set screws shall not protrude into wireways.

Compliance is checked by inspection and, if necessary, by dismantling and reassembling the luminaire.

7.4 Lampholders

7.4.1 The requirements for electrical safety of integral lampholders shall be those applicable to the luminaire as a whole with the lampholder and lamp in fully assembled position, as for normal use.

In addition, integral lampholders shall, when mounted in the luminaire, comply with the requirements concerning safety during insertion of the lamp as specified in the appropriate lampholder standard.

7.4.2 Connection of wiring to integral lampholder contacts may be made by any method giving reliable electrical contact over the service life of the lampholder.

7.4.3 Luminaires for tubular fluorescent lamps designed for end-to-end mounting shall be so designed that the lamp may be changed in the middle luminaire of a row without adjusting any other luminaire. In multi-lamp luminaires for tubular fluorescent lamps, the changing of any one lamp shall not impair the security of the other lamps.

Compliance with the requirements of 7.4.1 to 7.4.3 is checked by inspection.

7.4.4 Lampholders which are put into position by the user shall be capable of easy and correct positioning.

The distance between the pair of fixed lampholders for a fluorescent lamp intended to be set in a fixed position shall comply with the relevant standard sheet of IEC 60061-2 or (if IEC 60061-2 does not apply), the lampholder manufacturer's mounting instructions. Lampholders for tungsten filament lamps and lampholders for single-capped fluorescent lamps shall be adequately fixed to the body of the luminaire. The fixing device of lampholders shall have adequate mechanical strength so as to withstand such rough handling as can be expected in normal use. These requirements apply both to lampholders put in position by the user and to lampholders put in position by the luminaire manufacturer.

Compliance is checked by inspection, measuring and, if applicable, by the following mechanical tests.

- a) *Lampholders for a fluorescent lamp, with a test cap in position, are subjected, for 1 min, to a pressure applied to the centre of the cap in the direction of its axis of:*
- 15 N for G5 lampholders;
 - 30 N for G13 lampholders;
 - 30 N for lampholders for single-capped fluorescent lamps (G23, G10q, GR8, etc.). Values for other lampholders are under consideration.

NOTE For these tests, caps from standardized lamps can be used as the test caps.

After the test, the distance between the holders shall comply with the relevant standard sheet of IEC 60061-2 and the lampholder shall show no damage. The test cap for this test shall comply with the following standard sheets in IEC 60061-3:

- 7006-47C for G5 lampholders;
- 7006-60C for G13 lampholders;
- test caps for other lampholders are under consideration.

After the test on lampholders for single-capped fluorescent lamps, the lampholder shall not have moved from its position and the fixing device shall show no permanent deformation, so that the lamp, when reinserted, will come in its intended position.

- b) *Mounting brackets for Edison screw or bayonet-capped lampholders are subjected to testing for 1 min, to the following bending moments:*
- for E14 and B15 lampholders 1,2 Nm;
 - for E26, E27 and B22 lampholders 2,0 Nm;
 - for E39 and E40 lampholders 4,0 Nm.

After the test, the lampholder shall not have moved from its position and the fixing device shall show no permanent deformation, so that the lamp, when reinserted, shall be in its intended position.

7.4.5 For luminaires with ignitors, the peak pulse voltage occurring across contacts in lampholders which are part of the pulse voltage circuit shall not be greater than the pulse voltage marked on the lampholder or, in the absence of such marking, shall not be greater than:

- for 250 V rated lampholders 2,5 kV;
- for 500 V rated Edison screw lampholders 4 kV;
- for 750 V rated Edison screw lampholders 5 kV.

Compliance is checked by measurement of the voltage occurring across the lampholder contacts during the pulse test of 12.2.3 for luminaires with ignitors.

7.4.6 For luminaires with ignitors incorporating Edison screw lampholders, the centre contact of the lampholder shall be connected to the lead which supplies the pulse voltage.

Compliance is checked by inspection.

7.4.7 The insulating parts of lampholders and plugs incorporated in rough service luminaires shall be of a material resistant to tracking.

Compliance is checked by the test of 15.4.

7.4.8 Lamp connectors shall comply with all the requirements for lampholders other than those related to retaining the lamp in position. Means for retaining the lamp shall be provided by other parts of the luminaire.

Compliance is checked by inspection and test as required by 7.4.1 to 7.4.7.

NOTE The difference between lamp connectors and lampholders is clearly identified on the relevant data sheets of the IEC 60061 series.

7.4.9 Caps or bases originally developed for single-capped ELV lamps shall not be used in luminaires intended for use with general purpose tungsten-halogen lamps with rated voltages higher than 50 V.

NOTE Examples of such ELV fits are: G4, GU4, GY4, GX5.3, GU5.3, G6.35, GY6.35, GU7 and G53.

Luminaires intended for use with GU10 lamps only (with aluminized reflector) shall be provided with GU10 lampholders only.

Compliance is checked by inspection.

7.4.10 The use of a light source or light sources, designed to be connected by a lampholder or connector according to the IEC 60061 series, but used without the relevant lampholder or connector and with the electrical connections made in another way (e.g. with the wire soldered directly to the pins), is not allowed.

Compliance is checked by inspection.

7.5 Starterholders

Starterholders in luminaires other than class II shall accept starters which comply with IEC 60155.

For class II luminaires where the starter can be touched with the standard test finger (test probe B according to IEC 61032:1997, Figure 2) when the luminaire is fully assembled for use or open for the replacement of lamps or starters, the starterholder shall be one accepting only starters complying with the requirements for starters for class II luminaires given in IEC 60155.

Compliance is checked by inspection.

7.6 Terminal blocks

If luminaires are provided with connecting leads (tails) requiring a separate terminal block for the connection to the fixed wiring, adequate space for this terminal block shall be provided within the luminaire, or within a box delivered with the luminaire, or specified by the manufacturer.

This requirement applies to terminal blocks for connecting leads (tails) with conductor nominal cross-sectional areas not exceeding 2,5 mm².

Compliance is checked by measurement and by an installation test, using one terminal block for each two conductors to be connected together, as shown in Figure 31, and fixed wiring having a length of approximately 80 mm. The dimensions of the terminal blocks are those specified by the manufacturer or, in the absence of such a specification, 10 mm × 20 mm × 25 mm.

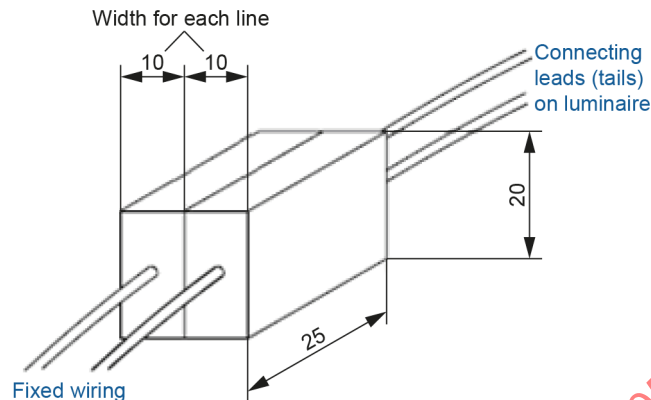

Figure 31 – Terminal block arrangement for installation test for luminaires with connecting leads (tails)

Unsecured terminal blocks are permitted when they are designed and insulated such that creepage distances and clearances in accordance with Clause 13 are always maintained for any position of the terminal block, and that damage to internal wiring is prevented.

7.7 Terminals and supply connections

7.7.1 In portable luminaires of class I and class II and in fixed luminaires of class I and class II that are frequently adjusted, adequate precautions shall be taken to prevent metal parts from becoming hazardous live parts due to a detached wire or screw. This requirement applies to all terminals (including supply terminals).

NOTE The requirement can be met by securing the wires adjacent to their entry to the terminals, by suitable dimensioning of the enclosure for the terminals, by the use of an enclosure of insulating material or by the provision of an insulating lining in the enclosure.

Examples of methods deemed efficient to prevent a wire from becoming detached are:

- wires are retained by a cord anchorage adjacent to the terminals;
- the conductor is clamped by a spring type screwless terminal;
- the wire conductor is anchored before soldering;
- wires are twisted together in a reliable manner;
- wires are fastened together by insulation tape, sleeves, or the like;
- the wire conductor is inserted into a hole in a printed board, bent and soldered, the hole having a diameter slightly greater than the conductor;
- the wire conductor is securely wrapped around the terminal by means of a special tool (see Figure 53);
- the wire conductor is crimped to the terminal by means of a special tool (see Figure 53).

The methods a) to h) apply to internal wiring and the methods a) and b) to rewirable external flexible cords.

Compliance is checked by inspection based upon the assumption that only one conductor can become detached at the same time.

7.7.2 Supply terminals shall be located or shielded in such a way that, if a wire of a stranded conductor escapes from a terminal when the conductors are fitted, there is no risk of contact between hazardous live parts and metal parts which can be touched with the standard test finger (test probe B according to IEC 61032:1997, Figure 2) when the luminaire is fully assembled for use or open for the replacement of replaceable light sources or starters.

Compliance is checked by inspection and by the following test.

An 8 mm length of insulation is removed from the end of a flexible conductor having the largest cross-sectional area specified in Clause 8. One wire of the stranded conductor is left free and the remainder are fully inserted and clamped in the terminal. The free wire is bent, without tearing the insulation back, in every possible direction, but without making sharp bends around barriers.

The free wire of a conductor connected to a hazardous live terminal shall not touch any metal part which is accessible or connected to an accessible metal part, and the free wire of a conductor connected to an earthing terminal shall not touch any hazardous live part.

This test does not apply to lampholders which have been separately approved in accordance with an appropriate IEC standard and to terminals of components where the construction method justifies a shorter length of free wire.

7.7.3 Terminals for supply cords shall be suitable for connection to be made by means of screws, nuts or equally effective devices.

Connecting leads (tails) shall comply with the requirements of 8.3.

NOTE 1 For luminaires designed to be connected by means of rigid (solid or stranded) conductors, screwless terminals of the spring type are effective devices, including the earth connection. No requirements are specified at present for using such terminals for the connection of supply cords.

NOTE 2 For luminaires designed to be connected by means of a supply cord and having a rated current not exceeding 3 A, soldered, welded, crimped and similar connections, including snap-on connectors, are effective devices, including an earth connection. Other similar connections include screwless terminals, insulation piercing or insulation displacement clamping terminals.

NOTE 3 For luminaires having a rated current exceeding 3 A, snap-on connectors are suitable if the connection can also be made without making use of the receptacle, for example, by means of a screwed connection for which a threaded hole is provided in the tab.

7.7.4 Welding method and material: The conductor shall be stranded or a solid wire of copper material. For thin wires, a ferrule may be used.

The welding method shall be spot welding only.

Welded connections can be used in types Y and Z attachments only.

Welded connections shall withstand the mechanical, electrical and heat test in normal use.

Compliance is checked by inspection and by the following tests.

a) Mechanical test

Apply the test of 17.5.2.

If the wire is fixed by a cord anchorage, the mechanical test is not applicable.

b) Electrical test

Apply the tests of 17.5.3.

c) Heat test

Apply the tests of 17.5.3.3.4 and 17.5.3.3.5.

7.7.5 Terminals, other than those for supply connection, which are not covered by separate standards for components, shall comply with the requirements of Clause 16 and Clause 17.

Terminals of lampholders, switches and similar parts used for multiple connection of internal wiring shall have dimensions adequate for the purpose and shall not be used for the connection of external wiring.

Compliance is checked by inspection and by the tests of Clause 16 and Clause 17.

7.7.6 If the external wiring or supply cord is unsuitable for the temperatures reached inside the luminaire, either a connection shall be provided at the point of entry of the external wiring into the luminaire for the use of heat-resistant wiring after this point, or heat-resisting parts shall be supplied with the luminaire to cover the part of the wiring placed inside it, which exceeds the wiring temperature limit.

Compliance is checked by inspection.

7.7.7 If during the installation or maintenance of a luminaire, electrical connections are made by a multi-pole plug and socket, unsafe connections shall be prevented.

Compliance is checked by inspection and by trying to make unsafe connections, for example by shifting the plug positions. The force applied to the plug during compliance checks shall take into account forces up to 30 N in any direction.

7.8 Switches

Switches shall be adequately rated and so fixed that they are secured against rotation and cannot be removed by hand.

Switches in flexible cables or cords and switched lampholders shall not be used in luminaires which are other than ordinary, unless the degree of protection against dust, solid objects or moisture of the switch is in accordance with the classification of the luminaire.

For luminaires intended for use on a polarized supply and where the luminaire has a single-pole on/off switch, the switch shall be wired into the live side of the supply or the side other than that identified as the neutral side.

Mechanical switches, when incorporated in or supplied with the luminaire, shall comply with the requirements of IEC 61058-1-1 for switches for appliances or IEC 60669-1 for switches for household and similar fixed electrical installations.

For switches complying with IEC 61058-1-1, the minimum number of operating cycles shall be 10 000.

Electronic switches, when incorporated in or supplied with the luminaire, shall comply with the requirements of IEC 61058-1-2 for switches for appliances or IEC 60669-2-1 for switches for household and similar fixed electrical installations.

Switches in flexible cables (cord switches) shall comply with the requirements of IEC 61058-2-1.

The above requirements are not applicable in the case of switches operating in ELV circuits with power lower than 15 W and a current lower than 0,5 A.

NOTE The 15 W limit is derived from IEC TS 60695-1-14.

Compliance is checked by measurement and by inspection.

7.9 Insulating linings and sleeves

7.9.1 Insulating linings and sleeves shall be so designed that they are reliably retained in position when switches, lampholders, terminals, wires or similar parts have been mounted.

NOTE Self-hardening resins, such as epoxy resins, can be used to fix linings.

Compliance is checked by inspection and by manual test.

7.9.2 Insulated linings, sleeves and similar parts shall have adequate mechanical, electrical and thermal strength.

Compliance is checked by inspection, by manual test and by the electric strength test in accordance with Clause 12. The thermal properties of wires and sleeves are checked in accordance with Clause 14. Heat resistant sleeves used as covering for wires attaining a temperature exceeding the values given in Table 22 shall comply with the requirements of the IEC 60684 series, taking into account the temperature measured on the wire in question. The sleeve shall be resistant to a temperature exceeding the temperature measured on the wire by 20 °C or withstand the following test.

- a) *Three test specimens of the sleeve, about 15 cm in length, are subjected to the humidity test of 11.3 and subsequently to the insulation resistance and electric strength tests according to Clause 12. A suitable uninsulated copper conductor or metal rod is passed through the specimens, and the outside is covered by a metal foil in such a way that no flashover at the ends of the samples can occur. The measurement of the insulation resistance and the electric strength test is then made between the copper conductor or metal rod and the metal foil.*
- b) *After the copper conductors or metal rods and metal foils have been removed, the specimens are placed in a heating cabinet for 240 h at a temperature of $T + 20$ °C, T being the measured temperature of the wire.*
- c) *The specimens are allowed to cool to room temperature and are then prepared as indicated in item a) above.*

Measurement of the insulation resistance and electric strength is then made between the copper conductor or metal rod and the metal foil.

Compliance is checked by the insulation resistance values and the test voltages specified in Table 15 and Table 16.

7.10 Double and reinforced insulation

7.10.1 For metal encased class II luminaires, contact between:

- mounting surfaces and parts with basic insulation only, and
- accessible metal parts and basic insulation,

shall be effectively prevented.

NOTE 1 This does not exclude the use of bare conductors if adequate protection is provided.

The wiring to be considered includes internal and external wiring of the luminaire, and fixed wiring of the installation.

Class II fixed luminaires shall be so designed that the required degree of protection against electric shock is not impaired as a result of the installation of the luminaire, for example by contact with metal conduits or metal sheaths of cables.

Capacitors shall not be connected between the live parts and the housing of metal-enclosed luminaires of protection class II, with the exception of type Y-interference suppression capacitors according to Table 4. If switches are used, they shall meet the requirements of 7.8.

NOTE 2 Contact between accessible metal parts and the basic insulation of internal wiring can be prevented by sleeves or similar parts which comply with the requirements for supplementary insulation.

Compliance is checked by inspection.

7.10.2 Any assembly gap with a width greater than 0,3 mm in supplementary insulation shall not be coincidental with any such gap in basic insulation, nor shall any such gap in reinforced insulation give straight access to hazardous live parts.

Openings larger than 0,3 mm in double or in reinforced insulation shall be designed so that hazardous live parts cannot be touched with the conical pin of test probe 13 shown in IEC 61032:1997, Figure 9.

NOTE In order to ensure effective forced ventilation or water draining in luminaires, it can be necessary to provide openings in the double or reinforced insulation.

In addition, compliance shall be ensured with the required degree of protection against electric shock in accordance with the IP classification of the luminaire.

Compliance is checked by inspection and measurement using the relevant probe(s) in accordance with the required degree of protection against electric shock.

7.10.3 Parts of class II luminaires which serve as supplementary insulation or reinforced insulation, shall either:

- be fixed so that they cannot be removed without being seriously damaged; or
- be unable to be replaced in an incorrect position.

Where sleeving is used as supplementary insulation on internal wiring, and where insulated linings are used in lampholders as supplementary insulation on external or internal wiring, the sleeving and lining shall be retained in position by positive means.

A sleeve is considered to be fixed by positive means if it can only be removed by breaking or cutting or if it is clamped at both ends or its movement on internal wiring is restricted by neighbouring components. A lining is considered to be fixed by positive means if it can only be removed by breaking or cutting or by dismantling the lampholder.

Parts, such as a tube of insulating material provided with a shoulder and used as a liner inside the nipple of a lampholder, are considered to provide supplementary insulation on external or internal wiring if they can be removed only by dismantling the lampholder.

Compliance is checked by inspection and by manual test.

Lining metal enclosures with a coating of lacquer or with any other material in the form of a coating which can be easily removed by scraping is not considered to meet this requirement.

7.10.4 Protective impedance device: Parts separated by insulation (e.g where basic, supplementary or double or reinforced insulation is required), may be bridged (conductive bridge) by resistors. For basic or supplementary insulation, it may consist of one single resistor, for each insulation layer. For double or reinforced insulation, they shall consist of at least two separate resistors connected in series of the same rated resistance, each one rated for the total working voltage so that their impedance is unlikely to change significantly during the individual lifetime of the luminaire.

They shall comply with the requirements of IEC 62368-1:2018, Clause G.10.

Parts separated by insulation (e.g. where basic, supplementary or double or reinforced insulation is required), may be bridged by a number of Y capacitors in series according to Table 4.

Y1, Y2 and Y4 capacitors shall comply with the relevant requirements of IEC 60384-14.

Table 4 – Overview of required Y capacitors

AC mains voltage RMS ^a	Overvoltage category	Bridged insulation	Capacitor type	Required number of capacitors
$U \leq 150 \text{ V}$	II	B or S	Y4	1
$U \leq 150 \text{ V}$	II	B or S	Y2	1
$U \leq 150 \text{ V}$	II	B or S	Y1	1
$U \leq 150 \text{ V}$	II	D or R	Y4	2
$U \leq 150 \text{ V}$	II	D or R	Y2	2
$U \leq 150 \text{ V}$	II	D or R	Y1	1
$150 \text{ V} < U \leq 300 \text{ V}$	II	B or S	Y2	1
$150 \text{ V} < U \leq 300 \text{ V}$	II	B or S	Y1	1
$150 \text{ V} < U \leq 300 \text{ V}$	II	D or R	Y2	2
$150 \text{ V} < U \leq 300 \text{ V}$	II	D or R	Y1	1
$300 \text{ V} < U \leq 500 \text{ V}$	II	B or S	Y2	1
$300 \text{ V} < U \leq 500 \text{ V}$	II	B or S	Y1	1
$300 \text{ V} < U \leq 500 \text{ V}$	II	D or R	Y2	2
$300 \text{ V} < U \leq 500 \text{ V}$	II	D or R	Y1	1

Key
 B basic insulation
 S supplementary insulation
 R reinforced insulation
 D double insulation

^a In the case of capacitors connected between live parts of circuits insulated from the mains and accessible parts, the voltage to be considered is the voltage indicated in Table T.1.

7.11 Electrical connections and current-carrying parts

7.11.1 Electrical connections shall be so designed that contact pressure is not transmitted through insulating material other than ceramic, pure mica or other material with characteristics which are at least equivalent, unless there is sufficient resilience in the metallic parts to compensate for any possible shrinkage of the insulating material.

Compliance is checked by inspection.

7.11.2 Self-tapping screws shall not be used for the connection of current-carrying parts, unless they clamp these parts directly in contact with each other, and are provided with a suitable means of locking.

Thread-cutting screws and self-tapping screws shall not be used for the interconnection of current-carrying parts of metal which is soft or liable to creep, such as zinc or aluminium.

Self-tapping screws may be used to provide protective earthing continuity, if it is not necessary to disturb the connection in normal use.

Compliance is checked by inspection.

EXAMPLE See Figure 32.

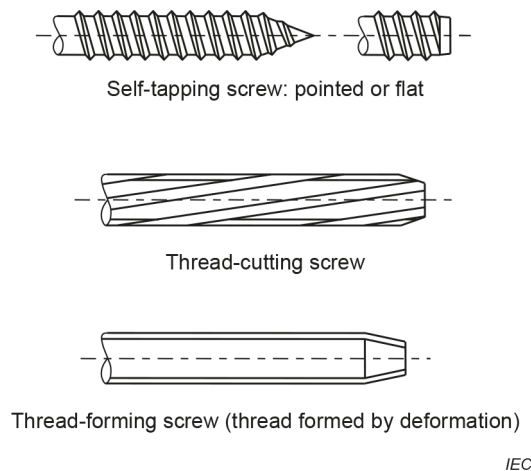

Figure 32 – Examples of self-tapping, thread-cutting and thread-forming screws

7.11.3 Screws and rivets which serve as electrical as well as mechanical connections shall be locked against loosening. Spring washers may provide satisfactory locking. For rivets, a non-circular shank or an appropriate notch may be sufficient.

Sealing compound which softens on heating provides satisfactory locking only for screw connections not subject to torsion in normal use.

Compliance is checked by inspection and manual test.

7.11.4 Current-carrying parts shall be of copper, an alloy containing at least 50 % copper, or a material having at least equivalent characteristics. This requirement is not applicable to current carrying parts of FELV, SELV or PELV supplying circuits where:

- the power of the load is lower than 15 W under normal operating conditions and
- the current in any load conditions (including short-circuit) shall not be higher than 2 A.

NOTE 1 Aluminium conductors can be accepted as having at least equivalent characteristics subject to an assessment of suitability being made in each individual case.

NOTE 2 The 15 W limit is derived from IEC TS 60695-1-14.

This requirement does not apply to screws which do not essentially carry current, such as terminal screws.

Current-carrying parts shall be resistant to, or adequately protected against, corrosion.

Copper and copper alloys containing at least 50 % copper are considered to meet this requirement.

NOTE 3 More information for use of permanent magnets as current-carrying parts is given in J.11 g).

Compliance is checked by inspection and, if necessary, by chemical analysis.

7.11.5 Current-carrying parts shall not be in direct contact with the mounting surface or wood.

Compliance is checked by inspection.

7.11.6 Electro-mechanical contact systems shall withstand the electrical stresses occurring in normal use.

Compliance is checked by subjecting the electro-mechanical contact systems to 100 operations at a speed which corresponds to practical usage (an operation is either making or breaking the contact). The test is made with alternating current at rated voltage, and the test current shall be 1,25 times the rated current of the electrical contact system. The power factor of the load shall be approximately 0,6, unless a different rated current is marked for resistive loads, in which case the load power factor shall be unity.

Where a luminaire is marked for both resistive and inductive loads, it shall be subjected to tests at power factors of both unity and 0,6.

Before and after the tests, the electro-mechanical contact systems shall be loaded with 1,5 times the rated current, and the voltage drop across each contact shall not exceed 50 mV.

Following completion of these tests, the electro-mechanical contact system shall withstand an electric strength test made in accordance with 12.2.

After the test, the samples shall show:

- no wear impairing their further use;*
- no deterioration of enclosures or barriers;*
- no loosening of electrical or mechanical connections.*

For electro-mechanical contact systems, the mechanical test of 7.14.3 is carried out simultaneously with this electrical test.

7.12 Screws, connections (mechanical) and glands

7.12.1 Screws and mechanical connections, the failure of which can cause the luminaire to become unsafe, shall withstand the mechanical stresses occurring in normal use.

Screws shall not be made of a material which is soft or liable to creep.

NOTE 1 Examples of such material are zinc, some grades of aluminium and several thermoplastics.

Screws which are operated for maintenance purposes shall not be of insulating material if their replacement by a metal screw can impair supplementary or reinforced insulation.

Screws used to provide protective earthing continuity, for example fixing screws for controlgear and other components, shall comply with the requirement in the first paragraph of 7.12.1. At least one screw retaining the controlgear has a mechanical and electrical function.

NOTE 2 Changing the screw retaining the controlgear is not considered to be maintenance.

Screws of insulating material used in cord anchorages and bearing directly on the cable or cord can be accepted.

NOTE 3 The replacement of such screws is not regarded as maintenance.

Compliance is checked by inspection, and screws and nuts transmitting contact pressure or which are likely to be tightened by the user shall be tightened and loosened five times. Screws and nuts of insulating material shall be removed completely during each operation of loosening of the screws. During the test, no damage impairing the further use of the fixing or screwed connection shall occur. After the test, it shall still be possible to introduce the screw or nut made of insulation material in the intended manner.

The test is made by means of a suitable test screwdriver or spanner, applying a torque as specified in Table 5, except that for screws of insulating material used in cord anchorage and bearing directly on the cable or cord, the torque is 0,5 Nm.

Table 5 – Torque tests on screws

Nominal outer thread diameter of screw mm	Torque Nm		
	1	2	3
Up to and including 2,8	0,20	0,40	0,40
Over 2,8 up to and including 3,0	0,25	0,50	0,50
Over 3,0 up to and including 3,2	0,30	0,60	0,50
Over 3,2 up to and including 3,6	0,40	0,80	0,60
Over 3,6 up to and including 4,1	0,70	1,20	0,60
Over 4,1 up to and including 4,7	0,80	1,80	0,90
Over 4,7 up to and including 5,3	0,80	2,00	1,00
Over 5,3 up to and including 6,0	–	2,50	1,25
Over 6,0 up to and including 8,0	–	8,00	4,00
Over 8,0 up to and including 10,0	–	17,00	8,50
Over 10,0 up to and including 12,0	–	29,00	14,50
Over 12,0 up to and including 14,0	–	48,00	24,00
Over 14,0 up to and including 16,0	–	114,00	57,00

The shape of the blade of the screwdriver shall suit the head of the screw to be tested. The screws shall not be tightened in jerks. Damage to covers is neglected.

Column 1 of Table 5 applies to metal screws without heads if the tightened screw does not protrude from the hole.

Column 2 applies to:

- other metal screws and nuts;
- screws of insulating material
 - having a hexagonal head with the dimensions across flats exceeding the overall thread diameter;
 - having a cylindrical head and a key socket with a cross-corner dimension exceeding the overall thread diameter;
 - having a head with a slot or cross slots, the length of which exceeds 1,5 times the overall thread diameter.

Column 3 applies to other screws of insulating material.

The values given in Table 5 for screws over 6,0 mm diameter apply to steel screws and the like, which are used mainly in the mounting of the luminaire.

The values given in Table 5 for screws over 6,0 mm diameter do not apply to nipple threads of lampholders, the requirements for which are specified in IEC 60238:2016, Clause 16.

The requirements of 7.12.1 do not apply to metal nuts used as means of fixing for push-button switches.

7.12.2 Screws transmitting contact pressure and screws which are operated when mounting or connecting the luminaires and having a nominal diameter less than 3 mm shall screw into metal.

Screws or nuts which are operated when mounting the luminaire or replacing lamps include screws or nuts for fixing covers, lids, etc. Connections for screwed conduits, screws for mounting the luminaire to its mounting surface, hand-operated fixing screws or nuts of glass covers and screwed lids are excluded.

Compliance is checked by inspection and for screws which are operated when mounting the luminaire or when replacing the lamps, by the test described in 7.12.1.

7.12.3 Screwed and other fixed connections between different parts of luminaires shall be made in such a way that they do not work loose through such torsion, bending stresses, vibration, etc., as can occur in normal use. Fixed arms and suspension tubes shall be securely attached.

NOTE Examples of means of preventing the loosening of connections are soldering, welding, lock nuts and set screws.

Compliance is checked by inspection and by attempting to loosen locked connections with a torque not exceeding:

- 2,5 Nm for thread size $\leq M 10$ or corresponding diameters;
- 5,0 Nm for thread size $> M 10$ or corresponding diameters.

For lampholders which are exposed to a rotary action during lamp replacement, compliance shall be checked by inspection and by attempting to loosen locked screwed mechanical connections. The test is not applied to lampholders retained in the luminaire by more than one fixing means (e.g. two fixing screws). The test torque shall be applied for 1 min in a clockwise and anti-clockwise direction with a torque not exceeding:

- 4,0 Nm for E40 lampholders;
- 2,0 Nm for E26, E27 and B22 lampholders;
- 1,2 Nm for E14 and B15 lampholders (except candle type);
- 0,5 Nm for E14 and B15 candle lampholders;
- 0,5 Nm for E10 lampholders.

For other lampholders exposed to a rotary action, a torque equal to two times the maximum withdrawal torque as specified in the lampholder requirements of IEC 60061-2 shall be applied for 1 min in a clockwise and anti-clockwise direction, but with a minimum of 1,2 Nm.

For push-button switches, the means of fixing are subjected to a torque not exceeding 0,8 Nm.

During the test, such screwed connections shall not loosen.

7.12.4 Screwed glands shall comply with the following test.

Screwed glands shall be fitted with a cylindrical metal rod having a diameter equal to the nearest whole number of millimetres below the internal diameter of the packing. The glands shall then be tightened by means of a suitable spanner, the moment given in Table 6 being applied to the spanner for 1 min.

Table 6 – Torque tests on cable glands

Diameter of test rod	Moment	
	Metal cable glands	Moulded plastic cable glands
mm	Nm	Nm
Up to 7	4,00	2,5
Over 7 up to 14	6,25	3,25
Over 14 up to 20	7,50	5
Over 20	10	7,50

After the test, the luminaire and the glands shall show no damage.

7.13 Mechanical strength

7.13.1 Luminaires shall have adequate mechanical strength and be so constructed as to be safe after such rough handling as can be expected in normal use.

Compliance is checked by applying blows to the sample by means of the spring-operated impact test apparatus specified in IEC 60068-2-75 or by other suitable means giving equivalent results.

NOTE 1 Equivalent impact energies obtained by different methods do not necessarily give the same test result.

The hammer spring shall be such that the product of the compression, in millimetres, and the force exerted, in newtons, equals 1 000, the compression being approximately 20 mm. The spring shall be adjustable so as to cause the hammer to strike with an impact energy and spring compression as given in Table 7.

IECNORM.COM : Click to view the full PDF of IEC 60598-1:2024

Table 7 – Impact energy and spring compression

Impact level	Impact energy J		Compression mm	
	Fragile parts	Other parts	Fragile parts	Other parts
Level 1 (Low impact energy): applicable to luminaires that are normally subjected to a low mechanical impact because of their installation on a wall or on a ceiling ^a	0,2	0,35	13	17
Level 2 (medium impact energy): applicable to luminaires where a higher mechanical strength is required because of their mobility or because they are easily accessible in normal use ^b	0,35	0,50	17	20
Level 3 (high impact energy): applicable to luminaires where a higher mechanical strength is required because of their installation without any additional protection or because they are subject to frequent handling ^c	0,5	0,70	20	24
Rough service luminaires, handlamps, ground recessed luminaires, air-handling luminaires, lighting chains, rope lights, luminaires for emergency lighting and handheld luminaires for use in clinical areas of hospitals (and health care buildings)	Other testing methods as specified in this document or in the specific parts of the IEC 60598-2 series.			
<p>Lampholders and other components are retested only insofar as they protrude beyond the projection of the outline of the luminaire. The front of the lampholders is never retested since in normal operation, this part is covered by the lamp.</p> <p>Fragile parts are parts such as glass and translucent covers providing only protection against dust, solid objects, moisture or UV. Fixing or closing mechanisms are not regarded as fragile parts.</p> <p>Protective shields required on account of 7.21 are regarded as fragile parts.</p> <p>^a Luminaires requiring Level 1 impact energy are: recessed luminaires, fixed general purpose luminaires, portable luminaires for wall mounting (for indoor use), and extra-low-voltage lighting systems.</p> <p>^b Luminaires requiring Level 2 impact energy are: portable floor and table luminaires for indoor use, photo and film luminaires and aquarium luminaires.</p> <p>^c Luminaires requiring Level 3 impact energy are: floodlights, road and street lighting luminaires, swimming pool luminaires, portable luminaires for outdoor use, portable luminaires for children, mains socket-outlet mounted nightlights and luminaires for stage lighting, television and film studios (outdoor and indoor).</p>				

NOTE 2 The level of impacts has been described for testing purposes only and are not considered as a product rating.

Translucent covers, neither providing protection against electric shock or UV, nor forming part of the protection against dust, solid objects, moisture and lamps, are not tested.

The sample is mounted or supported as in normal use on a rigid wooden board, cable entries being left open, knockouts opened, and cover-fixing and similar screws tightened with a torque equal to two-thirds of that specified in Table 5.

Three blows shall be applied to the point which is likely to be the weakest, paying special attention to insulating material enclosing hazardous live parts and to bushings of insulating material, if any. Additional samples can be necessary to find the weakest point; in case of doubt, the test shall be repeated on a fresh sample to which three blows only are applied.

After the test, the sample shall show no damage, in particular:

- a) hazardous live parts shall not have become accessible;*
- b) the effectiveness of insulating linings and barriers shall not have been impaired;*
- c) the sample shall continue to afford the degree of protection against ingress of dust, solid objects and moisture, in accordance with its classification;*

d) *it shall be possible to remove and to replace external covers without these covers or their insulating linings breaking.*

Breakage of an enclosure is, however, allowed if its removal does not impair safety.

In case of doubt, supplementary insulation or reinforced insulation is subjected to an electric strength test as specified in Clause 12.

Damage to the finish, small dents which do not reduce creepage distances or clearances below the value specified in Clause 13, and small chips which do not adversely affect the protection against electric shock, dust or moisture are neglected.

7.13.2 Metal parts enclosing hazardous live parts shall have adequate mechanical strength.

Compliance is checked by the appropriate tests of 7.13.3 and 7.20.2.

7.13.3 A straight unjointed test finger (test probe 11 according to IEC 61032:1997, Figure 7) is used. The finger is pressed against the surface with a force of 30 N.

During the test, metal parts shall not touch hazardous live parts.

After the test, covers shall not be excessively deformed and the luminaire shall continue to meet the requirements of Clause 13.

7.13.4 Plug-in independent controlgear and mains socket-outlet mounted luminaires shall have adequate mechanical strength.

Compliance is checked by the following test, which is made in a tumbling barrel in accordance with IEC 60068-2-31:2008, 5.3 (free fall repeated – procedure 2), according to the following details:

Height of the falls: 500 mm;

- 100 falls if the mass of the sample does not exceed 100 g;*
- 50 falls if the mass of the sample is > 100 g and ≤ 250 g;*
- 25 falls if the mass of the sample exceeds 250 g.*

Socket-outlet mounted luminaires shall be equipped with the appropriate light source.

NOTE 1 The number of falls is not that considered in the conformity criteria of IEC 60068-2-31:2008.

After the test, the sample shall continue to comply with the requirements of this document, but it is not necessary for the sample to be operative and any damage to the light source in the mains socket-outlet mounted luminaires shall be ignored. Provided that the protection against electric shock is not affected, small pieces which can have broken off the sample shall be ignored.

Distortion of pins and damage to the finish and small dents which do not reduce the creepage distances or clearances below the values specified in Clause 13 shall be ignored.

NOTE 2 In Australia and New Zealand there are specific and different requirements for socket-mounted controlgear and luminaires.

7.14 Suspensions, fixings and means of adjustment

7.14.1 Mechanical suspensions, including permanent magnet element(s), fixings and connections shall have adequate factors of safety.

Magnets shall not be used as the primary fixing of a fixed luminaire to the mounting surface.

NOTE 1 If a steel plate is provided by a luminaire manufacturer as part of the luminaire to be fixed by screws on a wall or ceiling, the steel plate is considered the primary fixing and not the permanent magnet used to fix the luminaire on this steel plate.

Compliance is checked by the appropriate tests from the following.

Test A: The fixings of the luminaire to the installation mounting surface and the fixings of other external parts held by the luminaire shall be securely kept in place. This test is applicable to:

- *suspended, fixed luminaire or track-mounted luminaire (ceiling – wall) – tested with four times the weight of the complete luminaire in addition to its weight;*
- *external parts fixed to the luminaire (e.g. diffuser, glass, reflector, louvre) – tested with four times the weight of the part being held, in addition to its weight. It is not necessary to test all external parts if compliance with the requirement of 7.14.1 is obvious from available information and by visual inspection, for example parts fixed by several screws.*

A constant, evenly distributed load equal to four times the weight either of the luminaire, or of the relevant part, as applicable, shall be added to their fixings in the normal direction of the load for a period of 1 h. There shall be no appreciable deformation of the components of the suspension and fixing system at the end of this period. Where alternative means of fixing or suspension are provided, each shall be tested separately.

Test B: For rigid suspension luminaires: A torque of 2,5 Nm is applied to the luminaires for a period of 1 min, first in a clockwise and then in an anticlockwise direction. For this test, it shall not be possible to rotate the luminaire relative to the fixed part by more than one revolution in either direction.

Test C: For rigid suspension brackets: Details of the test for rigid suspension brackets are as follows.

- a) *For heavy-duty brackets (e.g. workshop brackets), a force of 40 N shall be applied for 1 min, in various directions at the free end, with the bracket arm fixed as in normal use. The bending moment resulting from this test shall be not less than 2,5 Nm. When the test force has been removed, the bracket arm shall not be permanently displaced or deformed so as to endanger safety.*
- b) *For light-duty brackets (e.g. domestic brackets), a similar test to item a) shall be applied for 1 min, but with a force of 10 N, and the bending moment resulting from this test shall be not less than 1,0 Nm.*

Test D: For track-mounted luminaires: The mass of the luminaire shall be measured and shall not exceed the value as specified for the luminaire suspension devices or track adaptor.

Test E: For clip-mounted luminaires: A pull is applied to the cable without jerk for 1 min in the most unfavourable direction in normal use. During the test, the clip is mounted on standard test "shelves" made of ordinary window glass, one with a nominal thickness of 10 mm and one with the maximum thickness onto which the clip can be mounted. For this test, the thickness of the test shelf is increased by multiples of 10 mm. The clip shall not fall off the glass at a pull of 20 N.

Clip-mounted luminaires shall, in addition, be tested on the metal rod having a polished chromium plated finish and a nominal diameter of 20 mm. The luminaire shall not rotate under its own weight and shall not fall off the rod when a pull of 20 N is applied on the cable. The test on a polished metal rod is not applied to luminaires marked "not suitable for mounting on tubular material".

NOTE 2 The increase in the thickness of the test sheet, by 10 mm steps for the maximum thickness limits the possibility of forcing the clip onto the test shelf.

NOTE 3 The test shelf for a maximum thickness test can comprise layers of glass and wood, provided that the surfaces that are gripped by the clip of the luminaire are of glass.

Provided guidance or means are given by the manufacturer for the safe installation and use of a fixed luminaire or independent controlgear without fixing devices (holes, brackets, etc.), (see 6.4), this equipment can be regarded as complying with the requirements of this document.

It is not the intention of 7.14.1 to check the mechanical strength of the installation mounting surface. Any damage to the mounting surface is not a failure.

7.14.2 The mass of the luminaire suspended by flexible cables or cords shall not exceed 5 kg per flexible cable or cord. The total nominal cross-sectional area of the conductors of flexible cables or cords suspending pendants shall be such that the stress in the conductors does not exceed 15 N/mm^2 . When more than one flexible cable or cord is used, the mounting instructions shall state all necessary information to prevent any overloading of any cable or cord and ensure the even distribution of the load.

For the calculation of the stress, only the conductors are considered.

When the mass of the luminaire suspended by flexible cables or cords exceeds 5 kg per flexible cable or cord, or the maximum load allowed by the size of the conductor, the design of the luminaire or of the flexible cable or cord shall be such as to prevent any tension being applied to the conductors.

EXAMPLE A cable which incorporates suitable load-carrying cores.

In the case of special cable or cord with additional metallic wire or non-metallic fibres twisted together or included in the cable construction, and where the size of the conductors do not fulfil the maximum stress as above, it is not possible to prevent any stress on the conductors. The construction is considered acceptable if the cable including its fixing devices on both sides, can withstand a pull test applied for a period of 1 h with a force of 15 times the force normally applied to the cable in normal use. During the test all electrical connections shall be disconnected.

Following the test there shall be:

- no breakage of the cable,
- no degradation of the electrical insulation by performing the test in 12.2.3,
- no unsafe deformation of the fixing devices

For the semi-luminaires intended for connection to Edison screw or bayonet lampholders, the mass and effective bending moment shall not exceed the maximum value given in Table 8. The bending moment is relative to the point of contact, in the fully inserted position, of the semi-luminaire contact(s) with the centre contact of an Edison screw lampholder or the plungers of a bayonet lampholder.

Table 8 – Test on semi-luminaires

Lampholders	Luminaires	
	Maximum mass	Maximum bending moment
E14 and B15	1,8 kg	0,9 Nm
E27 and B22	2,0 kg	1,8 Nm
NOTE These values are lower than those to which a lampholder would normally be tested to provide a safety margin.		

Compliance is checked by inspection, by measurements, by calculation or by the pull test in 7.14.2 above.

7.14.3 Requirements for adjusting devices are given below.

- a) Adjusting devices and means of adjustment, for example joints, hoisting devices, adjusting brackets or telescopic tubes, shall be so constructed that cords or cables are not pressed, clamped, damaged or twisted along the longitudinal axis by more than 360° during operation.

If a luminaire has more than one joint, the 360° limit applies to each joint if they are not too close together. Each case shall be judged on its own merits.

Compliance is checked by the following test and inspection:

The adjusting device, equipped with the appropriate cable or cord shall be operated in accordance with Table 9. A cycle of operation is a movement from one extreme of the range to the other and back to the starting position. The rate of movement shall not cause the device to heat appreciably and shall not exceed 600 cycles per hour.

For electro-mechanical contact systems, this test is conducted simultaneously with the electrical connection test of 7.11.6.

During the test the values according to Table 13 shall not be exceeded.

After the test, not more than 50 % of the strands in a conductor shall be broken nor shall there be any serious damage to the insulation, if any, of the flexible cord. The cord or cable shall be subjected to, and shall satisfy, the insulation resistance and electric strength tests specified in 12.2.

Ball-joints and the like, where the clamping means can be adjusted, are tested with the joints only lightly clamped to avoid excessive friction. If necessary, the clamping areas are readjusted during the test.

For adjusting devices that consist of a flexible tube, the range of adjustment for this test is normally 135° in both directions from the vertical. However, where this adjustment cannot be achieved without using unreasonable force, the flexible tube is bent only to the positions where it will remain by itself.

- b) Luminaires with a means of adjustment intended to be installed within arm's reach, shall allow the operation of its intended function without impairing the stability of the luminaire or causing deformation of any part of the construction, nor cause injury due to temperatures above those specified in Table 21.

Compliance is checked by manipulating or handling the luminaire, by the means of adjustment as expected to represent normal use and by measurement of the temperatures during the test of 14.4.

- c) For luminaires intended to be mounted within arm's reach, the space surrounding any means of adjustment, except the light beam aperture, up to 5 cm away from the means of adjustment in any direction, shall comply with the temperature limits for the means of adjustment, as specified in Table 21. The same temperature limits apply also to any means of adjustment which are lit after the positioning of the luminaire light beam aperture.

Compliance is checked by positioning the luminaire light beam aperture and by measurement of the temperatures during the test of 14.4.

Table 9 – Test on adjusting devices

Type of luminaire	Number of cycles of operation
Luminaires intended to be frequently adjusted, for example drawing board luminaires	1 500
Luminaires intended to be occasionally adjusted, for example shop-window spotlights	150
Settable luminaires	45

- 7.14.4** Cords or cables passing through telescopic tubes shall not be fixed to the outer tube. Means shall be provided for avoiding strain on the conductors at the terminals.

Compliance is checked by inspection.

- 7.14.5** Guide pulleys for flexible cords shall be dimensioned to prevent damage to the cords by excessive bending. Grooves in the pulleys shall be well rounded, the diameter of the pulley at the bottom of the groove being at least three times the diameter of the cord. With the exception of SELV or PELV supplied luminaires, accessible metal pulleys shall be connected to a protective earth.

Compliance is checked by inspection.

- 7.14.6** Plug-in independent controlgear and mains socket-outlet mounted luminaires shall not impose undue strain on socket-outlets.

Compliance is checked by the following test. The plug-in independent controlgear or mains socket-outlet mounted luminaire is inserted, as in normal use, into a fixed socket-outlet pivoted about a horizontal axis through the centre lines of the contact tubes at a distance of 8 mm behind the engagement face of the socket-outlet. During this test, the plug-in independent controlgear shall be provided with 1 m of the cable supplying the luminaire in question or a cable specified by the manufacturer. The cable shall be free hanging during the test.

The additional torque applied to the socket-outlet to maintain the engagement face in the vertical plane shall not exceed 0,25 Nm.

For settable and adjustable mains socket-outlet mounted luminaires, the total torque transmitted to the socket-outlet during adjustment shall not exceed 0,5 Nm.

The socket-outlet used for the test shall have the earth contact (if any) removed unless the socket has shuttered pin receptacles that are uncovered by the action of inserting the earth pin.

7.15 Flammable materials

- 7.15.1** Covers, shades and similar parts not having an insulation function and which do not withstand the 650 °C glow-wire test of 15.3 shall be adequately spaced from any heated part of the luminaire (e.g. batteries, lamps, transformers) which can raise the material to its ignition temperature. These parts made of flammable material shall have suitable fastenings or supporting devices to maintain this spacing.

The spacing from heated parts mentioned above shall be at least 30 mm, unless the material is protected by a screen spaced at least 3 mm from the heated parts. This screen shall comply with the needle-flame test of 15.3.2, shall have no holes, and shall have a height and a length at least equal to the corresponding dimensions of the heated parts. A screen is not required in cases where the luminaire provides an effective barrier to burning drops.

NOTE The requirements of 7.15.1 are illustrated in Figure 33.

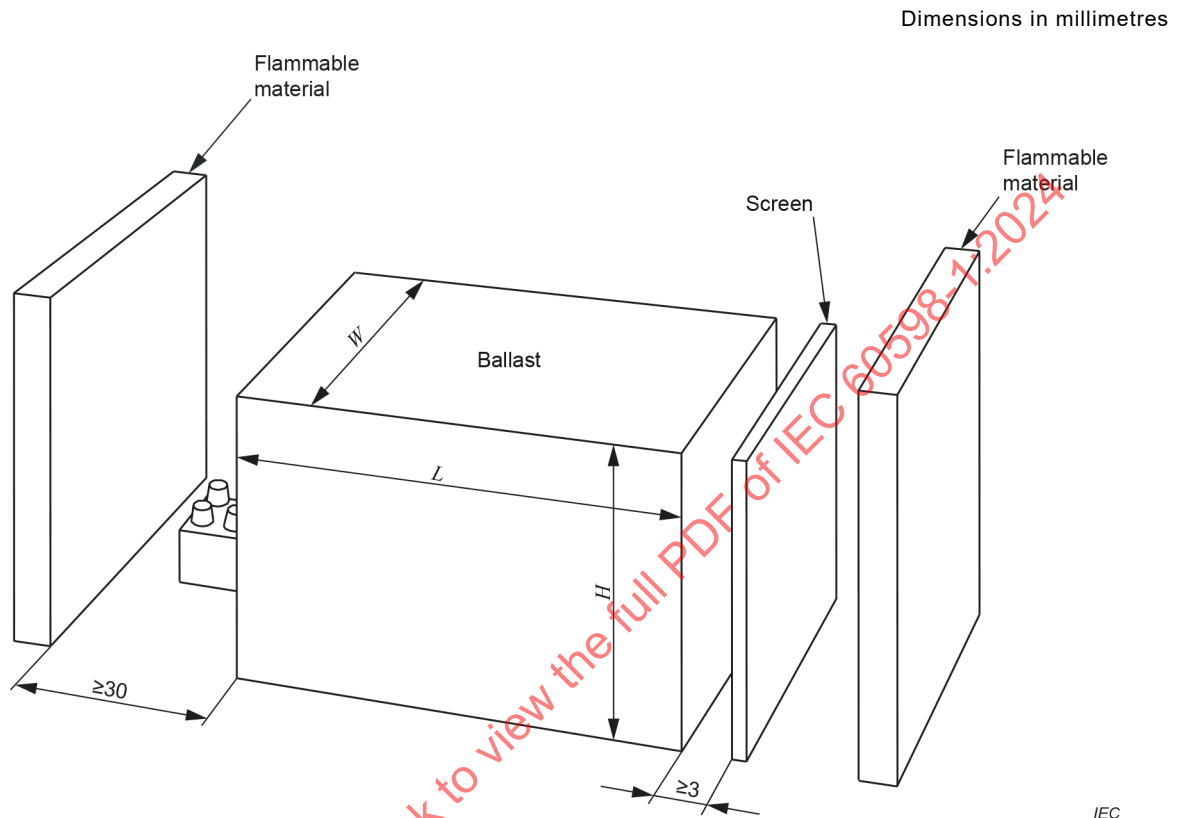

Figure 33 – Illustration of the requirements of 7.15.1

Materials which burn fiercely, such as celluloid, shall not be used.

The requirements of 7.15.1 do not apply to small parts such as wiring clips and resin-bonded paper parts used inside the luminaire.

Spacing is not required from electronic circuits if, under abnormal conditions, the operating current does not exceed normal conditions current by more than 10 %.

Spacing is not required from parts of luminaires incorporating a temperature sensing control which provides protection against overheating of the covers, shades or similar parts.

The requirements of 7.15.1 do not apply to a transformer supplied within an enclosure of its own, that is IP20 or higher, complying with the relevant part of the IEC 61558 series.

Compliance is checked by inspection, by measurement and by operating the luminaire in the abnormal condition with a slowly and steadily increasing current through the windings of the ballast or transformer, until the temperature sensing control operates. During and after this test, covers, shades and similar parts shall not catch fire and accessible parts shall not become hazardous live parts.

To check whether accessible parts have become hazardous live parts, a test in accordance with Annex A is made.

7.15.2 Luminaires made of thermoplastic materials shall withstand temperature rises due to fault conditions in ballasts or transformers and electronic devices, so that no danger occurs when mounted as in normal use.

This requirement shall be met by one of the following measures.

- a) Constructive measures ensuring that:
- during failure conditions, the components are kept in place, for example by mechanical temperature-independent supports;
 - luminaire parts cannot be overheated in such a way that hazardous live parts can become accessible.

Compliance is checked by inspection and by the test of 14.7.

- b) The use of a temperature sensing control to limit the temperature of the ballast or transformer and electronic device fixation points and exposed parts of the luminaire to a safe value. The temperature sensing control may be either an auto-reset thermal cut-out, a manual-reset thermal cut-out, or a thermal link.

Compliance is checked by the test of 14.7.

- c) The thermoplastic materials used for the luminaires shall be suitable for the maximum surface temperature permitted by the use of thermally protected controlgear complying with the relevant controlgear standard.

Compliance is checked by the test of 14.7.

7.16 Luminaires for mounting on normally flammable surfaces

7.16.1 Luminaires classified as suitable for mounting on a normally flammable surface shall comply with one of the following requirements of 7.16.2, 7.16.3 or 7.16.4.

NOTE 1 Annex L gives guidance on when to use the symbols and warnings.

The requirements of 7.16 are not applicable to a transformer supplied within an enclosure of its own, i.e. IP20 or higher complying with the IEC 61558 series. For shaver transformers or shaver supply units incorporated in a luminaire and complying with IEC 61558-2-5, the requirements of 7.16.2 apply. Electronic controlgear and small wound devices that may be incorporated into these components are exempt from the requirements of 7.16.

NOTE 2 Examples of small wound devices are windings having ferrite or non-laminated cores, these being normally mounted on a printed circuit board.

For luminaires incorporating controlgear, compliance with this requirement shall be met by spacing the controlgear from the mounting surface in accordance with 7.16.2, or by the use of thermal protection in accordance with 7.16.3, or by compliance with 7.16.4.

For luminaires that do not contain controlgear, the requirements are met by compliance with Clause 14.

Because of their application, luminaires which are provided with an adaptor for mounting on a track shall meet the requirements for direct mounting on normally flammable surfaces.

7.16.2 The controlgear shall be spaced from the mounting surface by a minimum distance of either:

- a) 10 mm, including the thickness of the luminaire case material when the spacing includes a minimum of 3 mm air space between the outer surface of the luminaire case and the mounting surface of the luminaire in the region of the controlgear, and a minimum of 3 mm air space between the controlgear case and the inner surface of the luminaire case. If there is no controlgear case, the distance of 10 mm shall apply from the active part, for example the core or windings of the controlgear.

The luminaire case should be continuous in the projected area of the controlgear to prevent a direct path of less than 35 mm between an active part of the controlgear and the mounting surface, otherwise the requirement of item b) applies;

or

- b) 35 mm.

NOTE The spacing of 35 mm is primarily to take into account stirrup-mounted luminaires where the controlgear to the mounting surface distance is often much greater than 10 mm.

In both instances, the luminaire shall be so designed that any necessary air space is automatically obtained when it is mounted as in normal use.



Compliance is checked by inspection and by measurements.

7.16.3 The luminaire shall incorporate a temperature sensing control to limit the temperature of the mounting surface of the luminaire to a safe value. This temperature sensing control may be either external to the controlgear or be part of a thermally protected controlgear in accordance with the relevant controlgear standard.

The temperature sensing control may be either a self-resetting thermal cut-out, a manual reset thermal cut-out or a thermal link (a thermal cut-out which operates only once and then requires replacement).

A temperature sensing control external to the controlgear shall not be of the plug-in type or an otherwise easily replaceable type. It shall be kept in a fixed position with regard to the controlgear or transformer.

Compliance is checked by inspection and by the test of 14.6.

The requirements of 7.16.3 are deemed to be complied with for luminaires incorporating "class P" thermally protected ballast or transformer, marked with the symbol , and temperature declared thermally protected controlgear or transformer, marked with the symbol  with a marked value equal to or below 130 °C, in accordance with the relevant auxiliary standard, without any further tests.

Luminaires incorporating controlgear or transformer without a symbol for thermally protected controlgear or with a marked value above 130 °C shall comply with the requirements of 7.16.2 or 7.16.4.

7.16.4 If the luminaire does not comply with the spacing requirements of 7.16.2, and does not incorporate thermal cut-outs in accordance with 7.16.3, it shall be so designed that it satisfies the test of 14.6.

NOTE This requirement and its test are based on the assumption that, during failure of the ballast or transformer, for instance owing to short-circuited windings or a short-circuit to the case, the ballast or transformer winding will not exceed 350 °C for a duration of more than 15 min and therefore that the temperature of the mounting surface will not exceed 180 °C for a duration of more than 15 min.

7.17 Drain holes

Drip-proof, rain-proof, splash-proof and jet-proof luminaires shall be so designed that if water accumulates in the luminaire it can drain out effectively, for example by opening one or more drain holes. Watertight luminaires shall have no provision for draining.

Compliance is checked by inspection and by the tests of Clause 11.

NOTE A drain hole in the back of a luminaire for surface mounting is effective only if the design ensures a clearance of at least 5 mm from the mounting surface, for example, by means of projections from the back.

7.18 Resistance to corrosion

NOTE Since the tests of 7.18 and Annex F can be destructive, they can be carried out on separate samples in accordance with 4.2.2.

7.18.1 Ferrous parts of luminaires with IP classification IPX1 and higher, the rusting of which can cause the luminaire to become unsafe, shall be adequately protected against rusting.

Compliance is to be checked by the following test.

All grease is removed from the parts to be tested. The parts are then immersed for 10 min in a 10 % solution of ammonium chloride in water at a temperature of $20\text{ °C} \pm 5\text{ °C}$. Without drying, but after shaking off any drops, the parts are placed for 10 min in a box containing air saturated with moisture at a temperature of $20\text{ °C} \pm 5\text{ °C}$.

After the parts have been dried for 10 min in a heating cabinet at a temperature of $100\text{ °C} \pm 5\text{ °C}$, their surfaces shall show no signs of rust. Traces of rust on sharp edges and any yellowish film removable by rubbing are ignored.

For small helical springs and the like, and for inaccessible parts exposed to abrasion, a layer of grease may provide sufficient protection against rusting. Such parts are subjected to the test only if there is doubt about the effectiveness of the grease film, and the test is then made without previous removal of the grease.

7.18.2 Contacts and other parts made of rolled copper or copper alloy sheet, the failure of which can cause the luminaire to become unsafe, shall be free from stress corrosion.

Compliance is checked by the test given in Annex F which shall be made on samples not subjected to any other test.

7.18.3 Parts of aluminium or aluminium alloy in drip-proof, rain-proof, splash-proof, jet-proof, watertight and pressure-watertight luminaires, shall be resistant to corrosion, if the luminaire can otherwise become unsafe.

NOTE Guidance on resistance to corrosion is given in Annex J.

7.19 Ignitors

Ignitors used in luminaires shall be electrically compatible with the associated ballast in the luminaire.

Compliance is checked by inspection.

7.20 Rough service luminaires

7.20.1 Rough service luminaires shall have adequate resistance to vibrations.

Compliance is checked by the following vibration test, as specified in IEC 60068-2-6.

The luminaire is fastened in its most onerous but normal position of installation to a vibration generator.

The direction of vibration is in the most onerous direction and the severity is:

duration: 30 min,
 amplitude: 0,35 mm,
 frequency range: 10 Hz, 55 Hz, 10 Hz,
 sweep rate: approximately one octave per minute.

After the test, the luminaire shall have no loosened parts which can impair safety.

7.20.2 Rough service luminaires shall have protection against ingress of solid objects and moisture of at least IP54.

Compliance is checked by inspection and the appropriate test of 11.2.

Rough service luminaires shall have adequate mechanical strength and shall not overturn under circumstances that can be expected during normal use. In addition, the fixation means of the stand to which the luminaire is connected shall have adequate mechanical strength.

Compliance is checked by tests a) to d) below.

a) Fixed rough service luminaires and portable rough service luminaires (not handheld)

Each of three samples of the luminaire shall be subjected to three single impacts, at points likely to be the weakest, on any surface normally exposed. The sample without lamp (or lamps) is mounted as in normal use on a rigid supporting surface.

The impacts are produced by dropping a steel sphere 50 mm in diameter weighing 0,51 kg from a height H (1,3 m) as shown in Figure 34, to produce an impact energy of 6,5 Nm.

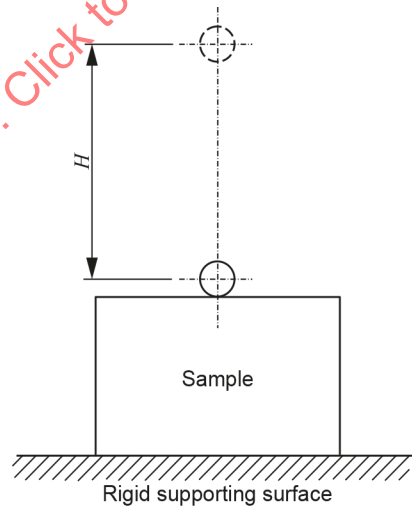

IEC

The rigid supporting surface should be arranged vertically for a side impact test.

Figure 34 – Apparatus for ball impact tests

Each of the three samples of a luminaire intended for outdoor use shall additionally be cooled to a temperature of $-5\text{ °C} \pm 2\text{ °C}$ and maintained at that temperature for 3 h.

Whilst the samples are at this temperature, they shall be subjected to the impact test specified above.

b) *Handheld luminaires*

The luminaire is caused to fall four times from a height of 1 m onto a rigid supporting surface. The falls are made from four different horizontal starting positions, the luminaire being turned through 90° around its axis between each fall. Lamps are removed, but protective glasses, if any, are not removed for this test.

NOTE A concrete floor is an example of a rigid supporting surface.

After the test of 7.20.2 a) or 7.20.2 b), the luminaire shall show no damage impairing safety and its further use. The parts protecting the lamp against damage shall not have loosened. Damage to the finish, deformation and dents which do not impair safety are neglected. Breakage of a protective glass or translucent cover is ignored if the glass or cover is not the sole means of protecting the lamp against damage.

c) *Luminaires delivered with a stand*

Any lamp(s) are removed before the tests.

The luminaire and stand shall not overturn at an angle of 6° from the vertical.

The luminaire shall withstand the impacts resulting from overturning four times from an angle up to 15° from the vertical.

The fixation means of the stand shall withstand a force of four times the weight of the luminaire in the most onerous direction.

If the luminaire overturns during the test on the plane inclined at an angle of 15° from the vertical, the test of 14.5 is made with the luminaire on a horizontal surface, in the most unfavourable of the overturned positions that can reasonably be expected in practice.

d) *Luminaires for temporary installations and suitable for mounting on a stand*

The luminaire shall withstand four impacts resulting from the following test.

Any lamp(s) are removed before the test.

The luminaire is suspended by an aluminium rod along a concrete or brick wall. The length of the rod is that of the stand as indicated for a possible stand in the mounting instruction.

The luminaire is lifted until the rod is in the horizontal plane and then allowed to fall freely against the wall.

After the test, there shall be no impairment of safety.

7.21 Protective shield

7.21.1 Because of the possible risk of lamp shattering, luminaires designed for tungsten-halogen lamps and luminaires designed for metal halide lamps shall be fitted with a protective shield. For tungsten-halogen lamps, the shield shall be of glass.

Luminaires designed to be used with self-shielded lamps only are exempt from this requirement, but shall be marked with the appropriate symbol.

NOTE 1 Lamps requiring a protective shield as part of the luminaire construction are supplied with an appropriate cautionary notice or their packaging is marked with the symbol shown hereafter:



[SOURCE: IEC 60417-6071:2011-09 – Caution, unprotected lamp]

NOTE 2 For lamps not requiring a protective shield as part of the luminaire construction (self-shielded lamps) their packaging is marked with the symbol shown hereafter:

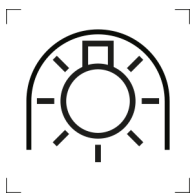

[SOURCE: IEC 60417-6030:2009-11 – Self-shielded lamp, general]

7.21.2 Parts of the lamp compartment shall be so designed that particles from a shattering lamp cannot impair safety.

7.21.3 All openings in the luminaire shall be such that no parts of a shattered lamp can leave the luminaire by a direct path (direct line of sight), including the rear of recessed luminaires.

7.21.4 Compliance with 7.21.1 to 7.21.3 is checked by inspection and by the following tests:

- the protective shield shall comply with the impact test of 7.13.1 with the impact energy of Table 7 for fragile parts. In case the mounting means of the glass shield is solely designed to withstand impacts from the inside, the test of 7.13.1 should be performed in that direction if possible;
- parts of the lamp compartment, if of insulating material, shall comply with the resistance to flame and ignition test of 15.3.

NOTE 1 This is intended to improve safety by eliminating the hazards due to chance failure of a lamp or incorrect application. Existing open luminaires not fitted with a protective shield do not necessarily present a hazard.

NOTE 2 The impact test of 7.13.1, which is performed from the outside, is regarded to be more severe than the impacts of glass particles. A specific test simulating the latter is therefore not necessary.

7.22 Attachments to lamps

Luminaires shall not incorporate attachments to lamps which can cause overheating or damage to the lamps, lamp caps or holders, luminaires or attachments.

Attachments to fluorescent lamps are only allowed if supplied or approved by the luminaire manufacturer. The total weight of the lamp plus attachment shall not exceed:

- 200 g for lamps with cap G5, and
- 500 g for lamps with cap G13.

Compliance is checked by inspection, by weighing and by thermal measurements, if appropriate.

NOTE Examples of attachments to incandescent lamps where there is a possibility that they will not comply with these requirements are bowl mirror reflectors, reflectors around lamps. Examples which can be permitted are springs for attachment of lightweight shades to lamps and similar devices.

7.23 Semi-luminaires

Semi-luminaires shall comply with all the relevant requirements for class II luminaires.

NOTE The class II symbol is omitted to avoid it being considered as applying to the complete luminaire in which the semi-luminaire is used.

7.24 Photobiological hazards

7.24.1 Actinic UV hazards for skin and eye (200 nm to 400 nm)

Luminaires shall not emit excessive UV radiation when used with light sources.

Compliance is checked by assessing the luminaire according to IEC 62471-7:2023, 5.3.

Luminaires designed to be used with self-shielded lamps only or luminaires with light sources having a UV emission limit $\leq 2 \text{ mW} \cdot \text{klm}^{-1}$, are in compliance with IEC 62471-7:2023, 5.3.

Luminaires with light sources emitting $\leq 6 \text{ mW} \cdot \text{klm}^{-1}$ and having a glass cover that covers all the light sources, are in compliance with IEC 62471-7:2023, 5.3.

NOTE 1 See IEC 60432-3 and IEC 62035 for lamp marking.

Luminaire with light sources emitting $> 6 \text{ mW} \cdot \text{klm}^{-1}$, Annex M describes methods to provide adequate shielding for UV radiation.

NOTE 2 See Annex M, procedure A or procedure B for the method of calculation to provide effective radiation shielding.

7.24.2 UV-A hazard for the eye lens (315 nm to 400 nm)

Luminaires shall not emit excessive UV-A radiation when used with light sources.

Compliance is checked by assessing the luminaire according to IEC 62471-7:2023, Clause 6.

NOTE According to IEC 62471-7:2023, 6.2, the UV-A exposure limit is not exceeded in luminaires, and no tests are necessary if no UV-A is intentionally added to the visible light.

7.24.3 Retinal blue light hazard

7.24.3.1 General

Luminaires shall comply with either 7.24.3.2 (assessment according to IEC 62471-7) or 7.24.3.3 (assessment according to IEC TR 62778).

NOTE It is the intention in the future edition of this document to remove 7.24.3.3 as IEC 62471-7 completely replaces IEC TR 62778. In the interim 7.24.3.2 or 7.24.3.3 can be used.

7.24.3.2 Luminaire assessment according to IEC 62471-7:2023

Luminaires with light sources, where the light source safety standard does not exclude the light source from the retinal blue light hazard assessment, shall be assessed according to IEC 62471-7:2023, 7.3.

NOTE 1 At the present time, the only light source types where it is important to consider blue light hazard are: LED, metal halide and some specialist tungsten-halogen types.

Luminaires shall not exceed the blue light radiance emission limits at the assessment distances for luminaires according to IEC 62471-7:2023, Table 2.

For fixed luminaires the assessment distance according to IEC 62471-7:2023, Table 2 may be increased where this is appropriate to the application of the specific luminaire. In this case, information for the used assessment distance x in metres shall be provided according to 6.3.22 a) of this document. If the luminaire fulfils the requirements in IEC 62471-7:2023, Table 2, no additional marking is required.

According to IEC 62471-7:2023 the data from the light source on blue light hazard can be transferred to the luminaire without additional test on the luminaire, provided that the light source has been classified into an application group according to the procedure of IEC 62471-7:2023, 7.2. If no light source assessment according to IEC 62471-7:2023, 7.2 is available, the full luminaire shall be assessed.

7.24.3.3 Luminaire assessment according to IEC TR 62778:2014⁴

Luminaires with light sources, where the safety standard does not exclude the light source from retinal blue light hazard assessment, shall be assessed according to IEC TR 62778.

Light sources with a blue light risk group rating greater than RG2 will require more onerous requirements protections to manage the blue light hazard

NOTE 1 At the present time, the only light source types where it is important to consider blue light hazard are: LED, metal halide and some specialist tungsten-halogen types.

NOTE 2 Requirements for luminaires using RG3 light sources are not yet developed because these products are not generally available on the market. Further requirements will be developed if needed in the future.

For luminaires using light sources not exceeding RG1 unlimited rating in accordance with IEC TR 62778, and for luminaires fully assembled for use which have been assessed as not exceeding RG1, under the same conditions, no requirements for retinal blue light hazard apply.

For luminaires having a threshold illuminance E_{thr} assessed in accordance with IEC TR 62778 the following requirements apply.

- a) For fixed mounted luminaires, an additional assessment in accordance with IEC TR 62778 shall be made to find the distance x m between the luminaire and the borderline between RG2 and RG1. The luminaire shall be marked and have instructions in accordance with 6.3.22 of this document. The manufacturers' declared photometric data for the luminaire can be used as the basis for the assessment.
- b) Portable and handheld luminaires exceeding RG1 at 200 mm assessed in accordance with IEC TR 62778 are required to be marked in accordance with 6.3.22 of this document.

NOTE 3 Where applicable, blue light hazard information is provided for the light source as required by the light source safety standard.

NOTE 4 In some luminaire designs, e.g. luminaires with integral light sources, it can be necessary for the complete luminaire to be tested.

Portable luminaires for children covered by IEC 60598-2-10, and mains socket-outlet nightlights, covered by IEC 60598-2-12, shall not exceed RG1 at 200 mm, in accordance with IEC TR 62778.

NOTE 5 Future amendments specific to IEC 60598-2-10 and IEC 60598-2-12 in this respect will follow.

7.24.4 Retinal thermal hazard (380 nm to 1 400 nm)

Luminaires with light sources, where the light source safety standard does not exclude the retinal thermal hazard, shall be assessed according to IEC 62471-7:2023, Clause 8.

NOTE With the present technology only arc-lamps (xenon or mercury high intensity discharge lamps), high current LED light sources or laser-based light sources have the potential to exceed the L_R limit of $280\,000\text{ W} \cdot \text{m}^{-2} \cdot \text{sr}^{-1}$.

Only for white light sources with a blue light hazard radiance L_B higher than $100\,000\text{ W} \cdot \text{m}^{-2} \cdot \text{sr}^{-1}$ the retinal thermal hazard shall be considered.

Luminaires shall not exceed the retinal thermal radiance limits as given in IEC 62471-7:2023.

⁴ Withdrawn.

7.24.5 Infrared hazard for the eye (780 nm to 3 000 nm)

Luminaires with light sources, where the light source safety standard does not exclude the infrared hazard assessment for the eye, shall be assessed according to IEC 62471-7:2023, Clause 9.

Light sources do not have sufficient E_{IR} radiation to exceed the limit in the application. Only applications where IR radiation is intentionally added to the visible light shall be evaluated.

7.24.6 Thermal hazard for the skin (380 nm to 3 000 nm)

According to IEC 62471-7:2023, Clause 10, the exposure limit is not exceeded and no tests are necessary.

7.25 Mechanical hazard

Luminaires shall have no sharp points or edges that can, during installation, normal use, or maintenance, create a hazard for the user.

Compliance is checked by inspection.

7.26 Short-circuit protection

7.26.1 Means shall be provided to prevent the impairing of safety due to unintended short-circuiting of uninsulated accessible SELV or PELV parts of opposite polarity. Class III luminaires supplied from a separate unspecified SELV or PELV supply can have one conductor insulated. Where insulation is not provided, the luminaire manufacturer can declare the maximum VA output and type reference of the SELV or PELV source, and the test in 7.26.1 can be conducted with this transformer or converter.

Compliance is checked by the following test.

A type test sample is operated at 0,9 to 1,1 times its rated voltage with its nominal load. In case the supply source is an ES1 PSE, no short-circuit test is required. A test chain as specified in 7.26.2 is hung over accessible uninsulated SELV or PELV parts. The test chain shall form the shortest possible path by being loaded at each end, subject to a maximum of 250 g with a weight equal to:

$$m = a \times n$$

where

m is the mass of the load of the test chain in grams (g);

a is the empirical factor 15;

n is the distance in cm between conductors in the unloaded state.

The test chain shall not melt through, nor shall any part of the type test sample reach a temperature exceeding the values of Table 21 and Table 22.

7.26.2 The test chain is a chain of sufficient length of an uncoated metal, having links in accordance with Figure 35 and made of 63 % Cu/37 % Zn. The chain shall have a resistance value of 2,5 Ω /m with a tolerance of ± 20 % when stretched with a load of 200 g/m. The resistance value of the test chain should be checked before each measurement.

Dimensions in millimetres

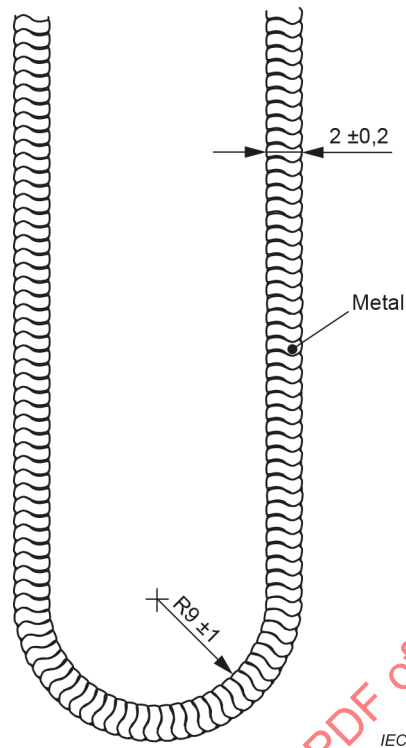

Figure 35 – Test chain

7.27 Terminal blocks with integrated screwless protective earthing contacts

Terminal blocks with integrated screwless protective earthing contacts shall be mounted in accordance with the requirements specified by the manufacturer with reference to Annex R.

Compliance is checked by inspection.

7.28 Fixing of thermal sensing controls

Any temperature sensing control external to the controlgear shall not be of the plug-in or an otherwise easily replaceable type. It shall be reliably kept in its specified position with regard to the controlgear.

The adhesive fixing of temperature sensing controls shall not be used where UV radiation emitted from a light source can degrade the reliability of the fixing due to photo-degradation during the life of the luminaire. Temperature sensing controls shall not be mounted outside of the luminaire enclosure.

Compliance is checked by inspection and, for temperature sensing controls with adhesive fixing, according to the following test.

The temperature sensing control, together with the controlgear or transformer to which it is fixed, is subjected to the temperature change test in accordance with IEC 60068-2-14:2023, test Na, according to the following details.

The specimen shall be subjected to 100 cycles between the minimum and the maximum values as given below.

The maximum temperature is the temperature measured on the adhesive material when the controlgear or transformer is loaded by a current equal to 0,95 times the value of the lowest current that causes the protective device to operate in steady state conditions.

The minimum test temperature is 0 °C.

The duration of exposure of the two temperatures is 30 min each.

As specified in IEC 60068-2-14:2023, the standard transfer time is between 2 min and 3 min. A transfer time (t_2) of less than 30 s is allowed, if an automatic test system is used.

During the test the temperature sensing control shall not undergo any change in fixing impairing its further use, especially with respect to its operating temperature. After the test, the temperature sensing control shall not be detached or moved from its designed position.

Transformers complying with the IEC 61558 series are not subjected to this test.

7.29 Luminaires with non-replaceable light sources

It shall not be possible to replace light sources or to give access to hazardous live parts without breaking the luminaire or its parts.

Compliance is checked by the following test.

Parts of the luminaire giving access to the light source which can be opened by hand or by using a tool shall be opened or removed.

Parts of the luminaire which are sealed, or glued, or fixed by screws which are designed and shaped to be used only once, or permanently embedded barriers, are not opened.

After removing all parts as detailed above, it shall not be possible to access hazardous live parts as checked with the test probe and test method according to Clause 10.

7.30 Luminaires with non-user replaceable light sources and non-user serviceable components

Where a protective cover is used over a non-user replaceable light source or a non-user serviceable component to provide protection against electric shock, and the cover is marked with the 'caution, electric shock risk' symbol detailed in 6.3.23, the cover shall be left in place during the tests and inspections detailed in Clause 9 and Clause 10. The cover shall be held securely in position by at least one fixing means requiring the use of a tool for its removal.

7.31 Insulation between circuits

7.31.1 General

Luminaires incorporating transformers or controlgear providing insulation between circuits and luminaires using circuits insulated from mains supply, shall provide suitable insulation between circuits and between these circuits and the external accessible conductive parts.

The same requirements apply to the circuits connected to the control terminals of a controllable luminaire where it is required to maintain the same level of insulation for all components. On the evaluation of the type of circuit to be considered, the information given by the controlgear manufacturer (see IEC 61347-1:2015, 7.1 k) shall be taken into account.

NOTE At present, on the market, the following types of control systems are available:

- FELV control signal, basic insulated from mains supply (e.g. Digital Addressable Lighting Interface and 1–10 V DC controls);
- SELV/PELV control signal, (e.g. DMX);
- control signal, not insulated from mains supply (e.g. push button control, phase cut, step dim).

Compliance is checked by the following requirements.

7.31.2 SELV or PELV circuits

The following sources may be used to supply SELV or PELV circuits:

- a safety isolating transformer in accordance with IEC 61558-2-6 or an equivalent part of the IEC 61558-2 series;
- a controlgear providing SELV or PELV in accordance with the IEC 61347 series;
- an electrochemical source (e.g. a battery) or another source independent of a higher voltage circuit;
- a PSE providing ES1 in accordance with IEC 62368-1, fulfilling the requirements of IEC 62368-3.

NOTE By using connectors in accordance with the IEC 62680 series or the IEC 60603 series the system will fulfil the requirements of SELV by default.

PELV circuits shall have one pole connected to earth for functional purposes. Functional earth of the PELV circuit can be connected to the protective earth circuit. Up to the point where the PELV circuit is connected to the protective earth or protective earth conductor, the earth connection of the PELV circuit shall fulfil the requirement for functional earth.

The voltage in the circuits shall not be higher than the limits defined for ELV.

SELV or PELV circuits shall be insulated from the mains supply by double or reinforced insulation (based upon a working voltage equal to mains supply voltage).

SELV or PELV circuits shall be insulated from other non SELV or PELV circuits (excluding FELV) by double or reinforced insulation (based upon a working voltage equal to the highest voltage in the circuits).

SELV or PELV circuits shall be insulated from FELV circuits by supplementary insulation (based upon a working voltage equal to the mains supply voltage).

SELV or PELV circuits shall be insulated from other SELV or PELV circuits by basic insulation (based upon a working voltage equal to the highest voltage in the circuits).

SELV or PELV circuits shall be insulated from accessible conductive parts by an insulation according to Table T.1.

In the case of controlgear in accordance with the IEC 61347 series, the SELV or PELV voltage to be considered for insulating purposes is the maximum output voltage indicated on the controlgear as "U-OUT".

Compliance is checked by inspection and by the test required in Clause 10, Clause 12 and Clause 13.

Plugs and socket-outlets in SELV or PELV systems shall comply with the following requirements:

- plugs shall not be able to make any electrical contact with socket-outlets of other voltage systems;
- socket-outlets shall not admit plugs of other voltage systems;
- plugs and socket-outlets in SELV circuits shall not have a protective conductor contact.

Compliance is checked by inspection and test.

7.31.3 FELV circuits

The following sources may be used to supply FELV circuits:

- a separating transformer in accordance with IEC 61558-2-1 or an equivalent part of the IEC 61558-2 series;
- a separating controlgear providing basic insulation between input and output circuits in accordance with the IEC 61347 series;
- an electrochemical source (e.g. a battery) or another source in a circuit separated by the mains supply by basic insulation only.

The voltage in the circuits shall not be higher than the limits defined for ELV.

FELV circuits shall be insulated from the mains supply by at least basic insulation (based upon a working voltage equal to the mains supply voltage).

It is not required that FELV circuits are insulated from the protective earth circuit except for functional purposes.

FELV circuits shall be insulated from accessible conductive parts by an insulation according to Table T.1.

Compliance is checked by inspection and by the tests required in Clause 10, Clause 12 and Clause 13.

Plugs and socket-outlets for FELV systems shall comply with the following requirements:

- plugs shall not be able to make any electrical contact with socket-outlets of other voltage systems;
- socket-outlets shall not admit plugs of other voltage systems;
- socket-outlets shall have a protective conductor contact.

Compliance is checked by inspection and test.

7.31.4 Other circuits

The insulation between circuits other than SELV, PELV or FELV and accessible conductive parts shall be in accordance with the requirements in Table T.1.

In class II construction, where equipotential bonding is used for the protection against indirect contacts with hazardous live parts (see Table T.1), the following requirements are applicable.

- All conductive parts are connected together so that two failures of the insulation result in a short-circuit.
- To check whether the conductive parts are reliably connected together, the test in 9.2.3 (earth continuity test with 10 A) shall be carried out.

- In the case of an insulation fault between hazardous live parts and accessible conductive parts, the conductive part shall not become a part that can cause an electric shock according to Annex A.
- For applications where one or more luminaires are supplied by another (the controlgear is mounted in the supplying luminaire) an equipotential bonding between the luminaires shall be used to prevent dangerous voltages between accessible luminaires. For this reason the supplying luminaire shall be provided with a terminal to connect the accessible conductive parts of the other luminaires and the other luminaires shall be constructed as class I luminaires.

Compliance is checked by applying the requirements of this document to check the insulation required in Annex T.

NOTE Examples of this kind of circuits are:

- output circuits of controlgear in accordance with the IEC 61347 series;
- circuits supplied by an isolating transformer in accordance with IEC 61558-2-4 or an equivalent part of the IEC 61558-2 series;
- circuits supplied by separating transformers in accordance with IEC 61558-2-1 which do not fulfil the requirements for FELV;
- circuits supplied by separating controlgear (other than FELV) and isolating controlgear in accordance with the IEC 61347 series.

7.31.5 Additional requirements for luminaires using controllable controlgear providing SELV output(s)

Luminaires with external control ports (i.e. controlled by an external wired circuit), and with controllable controlgear providing SELV output(s), shall use controlgear with insulation between the SELV output(s) and the SELV control port (e.g. terminals). The insulation between the SELV output(s) of the controlgear and its control port shall meet the requirements of IEC 61347-1 for interconnected controlgear.

NOTE 1 This is to reduce the risk of an unsafe accumulation of touch current due to the summation of individual touch currents from other luminaires in the same installation.

NOTE 2 The above mentioned requirement can be fulfilled by other components (e.g. external optocouplers or similar devices) in the luminaire that provide the same level of insulation between the two circuits.

NOTE 3 Information about the insulation between the output circuit and control port of the controlgear can be found in the manufacturer's data sheet.

NOTE 4 For luminaires without control ports for external connection, it is not necessary to use controlgear with insulation between the SELV output and the SELV control port (e.g. terminal), because touch current limitation is covered when applying Clause 10 and 12.3.

Compliance is checked by inspection and by the associated test required in this document.

7.32 Overvoltage protective devices external to controlgear

7.32.1 General

To limit the effects of lightning surges and other transient overvoltages, overvoltage protective devices may be used in luminaires and they can be either surge protective devices (SPDs) or surge protective components (SPCs). SPDs and SPCs in luminaires shall comply with the requirements given in 7.32.2 and 7.32.3 respectively.

SPDs or SPCs requiring connection to earth, shall be used only in fixed luminaires and connected to protective earth (Class I luminaires).

NOTE 1 Examples of SPCs are varistors (MOVs) and gas discharge tubes (GDTs). SPDs will utilize SPCs and are a complete assembly.

NOTE 2 The requirements in 7.32.2 and 7.32.3 are applicable to SPDs and SPCs external to the controlgear. These components used inside a controlgear are already tested according to the controlgear standard covering all possible working conditions including faults.

7.32.2 Surge protective devices (SPDs)

SPDs shall comply with IEC 61643-11 and with the following additional requirements:

The rated ambient temperature of the SPD shall be suitable for the condition inside the luminaire. This is verified according to the test in 14.4 of this document.

7.32.3 Surge protective components (SPCs)

7.32.3.1 General

SPCs covered by 7.32.3 are those connected across the mains (L to L or L to N). SPCs shall not be connected to earth or to other conductive parts of the luminaire.

NOTE Requirements for SPCs connected to earth are under consideration.

SPCs which are external to the controlgear shall comply with IEC 61051-2:2021 or IEC 61643-331:2020 and shall comply with the additional requirements as listed in 7.32.3.2 to 7.32.3.6.

7.32.3.2 Climatic conditions

For the selection of the device, SPCs shall comply with one of the following climatic conditions according to options A or B:

Option A – Climatic categories (see IEC 61051-2:2021, 4.1):

- the maximum SPC ambient temperature shall be suitable for the condition inside the luminaire. This is verified according to the test in 14.4 of this document;
- duration of damp heat, steady state test: 21 days.

or

Option B -Operating and storage temperature ranges (see IEC 61643-331:2020, 4.1):

- the maximum SPC ambient temperature shall be suitable for the condition inside the luminaire. This is verified according to the test in 14.4 of this document.

NOTE The ambient temperature is the micro ambient temperature inside the luminaire, measured close to the device.

7.32.3.3 Maximum continuous voltage

The maximum continuous voltage rating of the SPC device shall be:

- at least 1,25 times the rated voltage of the luminaire, or
- at least 1,25 times the upper voltage of the rated voltage range of the luminaire.

7.32.3.4 Surge capability

The SPC shall be suitable for the nominal discharge current (used in the combination wave test) as found in Table 10.

Table 10 – Nominal discharge current (used in the combination wave test)

Mains supply voltage	Combination pulse (open circuit voltage short-circuit current)
≤ 300 V	2,5 kV
	1,25 kA
> 300 V and ≤ 600 V	4 kV
	2 kA
> 600 V and ≤ 1 000 V	6 kV
	3 kA

7.32.3.5 SPC resistance to fire

The body of SPC shall comply with the needle flame test according to IEC 60695-11-5, with the following test severities:

- duration of application of the test flame: 10 s;
- flame duration after removal: 5 s.

Any burning drop from the sample shall not ignite the tissue paper as described by IEC 60695-11-5.

Compliance is checked by performing the above needle flame test on the SPCs and by fulfilling the test severity.

As the body of the SPC can become hot during operation, the requirements in 7.15.1 of this document shall be applied considering the body of the SPC as a heated part that can bring materials to their ignition temperature.

7.32.3.6 SPC overload test

This test shall be performed in the luminaire by disconnecting all other circuits leaving only the SPC connected in series with a test resistor. If the SPC complies with IEC 61643-331 as a thermally protected SPC, this test is not required.

The following test is conducted on an SPC connected across the mains (L to L or L to N) and is provided to simulate the overheating of the SPC during operation to avoid any damage of the component and the surrounding part of the luminaire.

The following test simulation circuit shall be used:

- *voltage is the AC source of $2 \times U_r$;*
- *current is the current resulting from a test resistor (resistance R_x) connected in series with the AC source;*
- *U_r is the rated voltage or the upper voltage of the rated voltage range of the luminaire.*

The test shall be performed with an initial test resistance $R_1 = (16 \times U_r) \Omega$.

If the circuit does not open immediately during the initial application of the test current, the test shall be continued until temperature stability.

Subsequently, the test shall be repeated with new values of R_x (R_2, R_3, R_4 , etc.) until the circuit opens.

- $R_2 = (8 \times U_r) \Omega$
- $R_3 = (4 \times U_r) \Omega$
- $R_4 = (2 \times U_r) \Omega$
- $R_x = (0,5 \times R_{(x-1)}) \Omega$

During the test, there shall be no emission of flames or molten material or production of flammable gases. Following the test, the creepage and clearance distance shall not be reduced and no part of the luminaire shall have deformation impairing safety.

To check whether gases liberated from component parts are flammable or not, a test with a high-frequency spark generator shall be made.

During the test, the circuit can open due to the operation of a protective device such as a fuse or a thermal fuse.

NOTE This test covers the end of life behaviour of an SPC and no extra protection is necessary in the circuit.

7.33 Luminaire powered via information technology communication cabling

A luminaire powered via information technology communication cabling shall fulfil the requirements for class III.

The rated voltage of the luminaire shall not exceed the maximum voltage related to the used connector.

NOTE 1 Indoor use is expected to be the main application for luminaires powered via information technology communication cabling, however when used in other applications, additional requirements for outdoors and IP rating could be necessary.

The luminaire shall be designed to be in line with the limits of the electrical parameters of a PSE. Information regarding the limits of a PSE is given in Annex U.

The luminaire shall not create any hazard when supplied with

- 130 % of the rated input voltage of the luminaire at the relevant input port for circuits greater than 5 V DC, with a minimum of 7,5 V DC and
- 150 % of the rated input voltage of the luminaire at the relevant input port for circuits less than or equal to 5 V DC.

Any consequential failure of components in the luminaire shall not create a hazard.

NOTE 2 This fault condition in the PSE is an abnormal condition for the luminaire.

Compliance is checked by the tests in Clause 14.

7.34 Electromagnetic fields (EMF)

Luminaires shall not produce harmful electromagnetic fields.

Compliance is checked according to IEC 62493:2015 and IEC 62493:2015/AMD1:2022.

NOTE IEC 62493:2015, 4.2.2 details common types of luminaire constructions that are deemed to comply with the requirements of this EMF standard without the need for testing.

7.35 Protection against moving fan blades

Motor driven fan blades for active cooling of luminaires shall not be accessible when the luminaire has been installed and wired as in normal use, and when it is opened as necessary for replacing replaceable light sources or (replaceable) components. The test is carried out with a standard test finger (test probe B according to IEC 61032:1997, Figure 2), when inserted into openings with a force of 30 N. For portable luminaires test probe 19 according to IEC 61032:1997, Figure 13 shall be used for this test. This test is not carried out for fans that have leading edges and tips rounded with a radius of not less than 0,5 mm and:

- if they have a hardness less than D60 Shore, or
- if they have a peripheral speed less than 15 m/s when supplied at rated voltage, or
- if the fan has an input power not exceeding 2 W when supplied at rated voltage.

NOTE D60 is referenced in ISO 48-4:2018.

Compliance with this requirement is checked by inspection and if necessary by testing with the relevant test probe. The test probe shall be applied in every possible position with the specified force. No contact to the fan blade shall be made.

7.36 Track-mounted luminaires

Additionally, track-mounted luminaires shall be tested in accordance with IEC 60570:2003/AMD2:2019, Annex A.

8 External and internal wiring

8.1 General

Clause 8 specifies general requirements for the electrical connections to a supply and for the internal wiring of luminaires.

8.2 Supply connection and other external wiring

8.2.1 Luminaires shall be provided with one of the following means of connection to the supply:

a) fixed luminaires:

- devices for the connection of luminaires;
- terminals, plugs for engagement with socket-outlets;
- connecting leads (tails);

Where the luminaire is delivered with connecting leads (tails) and without a means of connection to the supply, the manufacturer of the luminaire shall specify which terminal block may be used which shall conform to IEC 60998-2-1 or IEC 60998-2-2; either the terminal block to be used shall be specified or the following shall be defined:

- the type of terminal (screw or screwless);
- number of terminals;
- rated voltage;
- rated connecting capacity;
- any necessary preparation of the ends of conductors;
- any fixing method;

The requirements of 7.6, 7.7.1, 7.7.2, 7.10.1, 13.2, Clause 14 and 15.2 shall apply.

- supply cords;
- adapters for engagement with supply tracks;

- appliance inlets;
 - installation couplers;
 - class III luminaires where the power supplied via information technology communication cabling having the appropriate connectors, for instance plugs described in the IEC 60603 series and the IEC 62680 series;
- b) portable luminaires
- supply cords; with plugs; appliance inlets;
 - class III luminaires where the power supplied via information technology communication cabling having the appropriate connectors, for instance plugs described in the IEC 60603 series and the IEC 62680 series;
- c) track-mounted luminaires
- adaptors or connectors;
- d) semi-luminaires
- Edison screw or bayonet cap.

Portable luminaires intended for wall mounting and incorporating a junction box and cord anchorage may be delivered without a supply cord, if instructions for mounting are enclosed with the luminaire.

Luminaires declared by the manufacturer to be suitable for use outdoors shall not have PVC-insulated external wiring. This requirement is not applicable to Class III or SELV or PELV circuits in luminaires (up to and including 25 V AC or 60 V DC or 25 V peak interrupted DC voltage with a frequency between 10 Hz and 200 Hz) and to external wiring that is protected from the outdoor environment by other means, for example wiring between the lamp compartment and the connection to the incoming main supply inside (in its whole length) a lighting column.

NOTE 1 In Australia, Austria and Japan, PVC insulated cables are acceptable for outdoor use.

NOTE 2 A wall-mounted luminaire can be portable if it is fixed to its support by means of a wing screw, a clip or a hook (see 3.9).

NOTE 3 In some countries, luminaires intended to be connected to the supply via a socket-outlet need to be fitted with the supply cord and appropriate plug.

8.2.2 Supply cords used as a means of connection to the supply, when supplied by the luminaire manufacturer, shall be at least equal in their mechanical and electrical properties to those specified in the IEC 60227 series and the IEC 60245 series, as indicated in Table 11, and shall be capable of withstanding, without deterioration, the highest temperature to which they may be exposed under normal conditions of use.

Materials other than polyvinyl chloride and rubber are suitable if the above requirements are met, but in such cases, the particular specifications of IEC 60227-2 and IEC 60245-2 do not apply.

Unsheathed basic insulated conductors shall be subjected to the electric strength test specified in Clause 12 for SELV or PELV (500 V).

Table 11 – Supply cord

Luminaire	Rubber	PVC	No insulation
Ordinary class I luminaires	60245 IEC 89 ^c	60227 IEC 52 ^c	
Ordinary class II luminaires	60245 IEC 53 ^c	60227 IEC 52 ^c	
Luminaires other than ordinary class I and class II	60245 IEC 57 ^c	60227 IEC 52 ^{a c}	
Portable rough service luminaires	60245 IEC 66 ^c		
Class III or with SELV or PELV circuits luminaires AC: $U \leq 25\text{ V}$ DC: $U \leq 60\text{ V}$ Interrupted DC voltage for frequencies between 10 Hz and 200 Hz: $\leq 25\text{ V peak}$			Uninsulated conductor ^b
Class III or with SELV or PELV circuits luminaires AC: $25\text{ V} < U \leq 50\text{ V}$ DC: $60\text{ V} < U \leq 120\text{ V}$	Unsheathed basic insulated conductor		
^a For indoor use only. ^b In accordance with the IEC 60364 series, uninsulated conductors are not allowed in certain special installations and locations, e.g. locations containing a bath or shower (IEC 60364-7-701). ^c For supply voltages greater than 250 V, higher voltage grade cables and cords than those given in this table can be necessary.			

To provide adequate mechanical strength, the nominal cross-sectional area of the conductors of external wiring, for example supply cord and interconnecting cables, shall be not less than specified in Table 12.

IECNORM.COM : Click to view the full PDF of IEC 60598-1:2024

Table 12 – Wiring dimension

Condition	Minimum nominal conductor cross-section ⁱ	
	mm ²	
	Ordinary luminaire	Other than ordinary luminaire
General	0,75	1,0
Declared to be "For indoor use only", in accordance with 6.4.15.	0,75	0,75
When the luminaire is provided with a 10/16 A socket-outlet.	1,5	1,5
Class III luminaires or SELV or PELV circuits connections between parts of other luminaire types, with 2 A maximum rated current.	0,4 ^{a c}	0,4 ^{a c}
Class III luminaires or SELV or PELV circuits connections between parts of other luminaire types, with 2 A maximum rated current, consisting of cables with two or more conductors.	0,2 ^{a b c}	0,2 ^{a b c}
Conductors connected to SELV or PELV controlgear that limits output current to maximum 2 A.	< 0,2 (No minimum) ^{d e g h}	< 0,2 (No minimum) ^{d f g h}
<p>^a Provided that current-carrying capacity and mechanical properties are adequate.</p> <p>^b Able to withstand the normal and short-circuit current provided by the associated controlgear.</p> <p>^c Compliance is checked by inspection and by the test in 8.2.10.</p> <p>^d Selected in relation to the maximum available current, compliance is checked by the test in 8.4.</p> <p>^e Controlgear output voltage under load does not exceed 25 V RMS or 60 V ripple free DC and no-load voltage does not exceed 35 V peak or 60 V ripple free DC.</p> <p>^f Controlgear output voltage not exceeding 12 V RMS or 30 V ripple free DC.</p> <p>^g To check mechanical properties, the conductor assembly, fixed to the luminaire, shall be subjected to the test in 8.2.10.4.</p> <p>^h The minimum insulation thickness shall be selected to withstand the voltage stress occurring, see Table T.1.</p> <p>ⁱ IEC 60228 specifies that the requirement associated with the nominal conductor cross-section is a maximum resistance value, not a physical measure of the area. For nominal sizes of 0,5 mm² and above, these values are listed in IEC 60228. For lower cross-sections the resistance value is calculated accordingly.</p>		

8.2.3 Where the supply cord is provided with the luminaire, it shall be connected to the luminaire by one of the following methods:

- type X attachment;
- type Y attachment;
- type Z attachment.

8.2.4 *Compliance with the requirements of 8.2.1 to 8.2.3 is checked by inspection and, if necessary, by fitting the appropriate flexible cable or cord.*

8.2.5 Terminations within luminaires utilizing a type Z attachment shall not be made by means of screwed connections.

8.2.6 Cable entries shall be suitable for the introduction of the conduit or the protective covering of the cable or flexible cord so that the cores are completely protected, and they shall provide the degree of protection against dust or moisture in accordance with the classification of the luminaire, when the conduit, cable or flexible cord is fitted.

8.2.7 Cable entries through rigid materials for external flexible cables and cords shall have smoothly rounded edges of a minimum radius of 0,5 mm.

Compliance with the requirements of 8.2.5 to 8.2.7 is checked by inspection and by manual tests.

8.2.8 If, in class II luminaires, in settable and adjustable luminaires or in portable luminaires other than those for wall mounting, a flexible cable or cord where entering or leaving the luminaire passes through accessible metal parts or through metal parts in contact with accessible metal parts, the opening shall be provided with a tough bushing of insulating material having smoothly rounded edges, so fixed that it cannot easily be removed. Bushings of material likely to deteriorate with age shall not be used in openings with sharp edges.

NOTE 1 The term "easily removable bushing" is used to describe a bushing which can be pulled out of its mounting by movement of the luminaire during its life or by inadvertent handling of the luminaire. Examples of accepted fixings include use of lock-nut, appropriate adhesive such as self-hardening resin, or properly sized push-fits.

NOTE 2 An example of materials known for deterioration with age is natural rubber.

If tubes or other guards are provided for the protection of flexible cables or cords at the entry to the luminaire, they shall be of insulating material.

Helical metal springs and similar components, even when covered with insulated material, are not guards.

Compliance is checked by inspection.

8.2.9 Bushings which screw into the luminaire shall be locked in position. If bushings are fixed with an adhesive, it shall be of the self-hardening resin type.

Compliance is checked by inspection.

8.2.10 Cord anchorages shall be in accordance with the requirements of 8.2.10.1 to 8.2.10.5.

8.2.10.1 Unless meeting the requirements of 8.2.10.5, luminaires provided with or designed for use with a supply cord or other external flexible cable or cord shall have a cord anchorage such that the conductors are relieved from strain, including twisting, where they are connected to the terminals, and such that their covering is protected from abrasion. It shall be clear how the relief from strain and the prevention of twisting is intended to be effected. For luminaires supplied without a cable or cord, suitable test cables or cords of the largest and smallest sizes recommended by the luminaire manufacturer shall be used for the tests.

It shall not be possible to push the flexible cable or cord into the luminaire to such an extent that the cable or cord is subjected to undue mechanical or thermal stress. Methods such as tying the cable or cord into a knot or tying the ends with string shall not be used.

Cord anchorages shall be of insulating material or be provided with a fixed insulating lining if an insulation fault on the cable or cord can make accessible metal parts live.

8.2.10.2 Cord anchorages for a type X attachment cord shall be constructed and located such that:

a) at least one part is fixed to, or is integral with, the luminaire;

NOTE A cord anchorage is described as fixed to or held by the luminaire if this is actually the case when the wiring is inserted and the luminaire is completely assembled.

b) they are suitable for the different types of supply cord that are appropriate for connecting to the luminaire, except where the luminaire allows only one type of cable or cord to be fitted;

c) they do not damage the supply cord and they are unlikely to be damaged when they are tightened or loosened in normal use;

d) the whole supply cord with its covering, if any, is capable of being mounted into the cord anchorage;

- e) the supply cord does not touch clamping screws of the cord anchorage if these screws are of metal and are accessible or electrically connected to accessible metal parts;
- f) the supply cord is not clamped by a metal screw which bears directly on the cable or supply cord;
- g) replacement of the supply cord does not require the use of a tool specially designed for the purpose.

Glands shall not be used as cord anchorages in portable, settable or adjustable luminaires, unless they have provision for clamping all types and sizes of cables and cords which can be used for the supply connection. Anchorages of labyrinth type may be used if it is evident from the design or by means of suitable marking how the flexible cable or cord is to be mounted.

Compliance is checked by the test of 8.2.10.4.

8.2.10.3 For types Y and Z attachments, cord anchorages shall be adequate.

Compliance is checked by the test of 8.2.10.4. The test is carried out on the cable or cord supplied with the luminaire.

8.2.10.4 *Compliance is checked by inspection and by the following tests which are made with the cable or cord which is fitted to the luminaire as delivered.*

The conductors are introduced into the terminals and the terminal screws, if any, are tightened just sufficiently so as to prevent the conductors from easily changing their position.

The cord anchorage is used in the normal manner, clamping screws, if any, being tightened with a torque two-thirds of that specified in Table 5.

After this preparation, it shall not be possible to push the cable or cord into the luminaire in such a way as to cause movement of the cable or cord at the terminals, or to cause the cable or cord to come into contact with moving parts or parts which operate at a temperature higher than that permissible for the insulation of the conductors.

The cable or cord is then subjected 25 times to a pull of the value specified in Table 13.

The pulls are applied without jerks, each time for 1 s. The measurement of the longitudinal displacement of the cable or cord is made during this test. A mark is made on the cable or cord at a distance of approximately 20 mm from the cord anchorage while it is subjected to the first pull and during the 25th pull, the mark shall not have been displaced by more than 2 mm.

The cable or cord shall then be subjected to a torque of the value specified in Table 13.

During and after the above tests, the conductors shall not have moved noticeably in the terminals and the cable or cord shall not be damaged. If it can be assumed that the terminals work partly as cord anchorage (for example because the wires between cord anchorage and terminal are elongated), the test shall be repeated with an opened connection between conductors and terminals, to ensure that the cord anchorage function is independent of the electrical connection.

Table 13 – Tests for cord anchorage

Total nominal cross-sectional area of all conductors together mm ²	Pull N	Torque Nm
Up to and including 0,4	30	-----
Over 0,4 up to and including 0,75	30	0,08
Over 0,75 up to and including 1,5	60	0,15
Over 1,5 up to and including 3	60	0,25
Over 3 up to and including 5	80	0,35
Over 5 up to and including 8	120	0,35

8.2.10.5 Luminaires provided with or designed for use with a supply cord or other external flexible cable or cord may be exempt from the need for a cord anchorage if they have a maximum current of 2 A, including short-circuit current, available in the circuit prior to the operation of an overcurrent limiting device and the following conditions and test requirement are met.

- ordinary Class III luminaire supplied with SELV at a voltage not exceeding 25 V RMS or 60 V ripple free DC;
- ordinary Class III luminaire supplied with PELV at a voltage not exceeding 12 V RMS or 30 V ripple free DC;
- other than ordinary Class III luminaire supplied at a voltage not exceeding 12 V RMS or 30 V ripple free DC

The following test requirement shall be complied with.

Each conductor of a lead assembly connected to the circuit shall be subjected to a pull test of 30 N. The pull is applied without jerks, for 1 min, in the direction opposite to that used for the application or insertion of the conductor or lead assembly. During the test, the conductor or lead assembly shall not have moved noticeably in the terminals nor become disconnected in case of soldering. If the lead, cord or cable can be pushed inside the enclosure, contact with hazardous live parts, hot parts exceeding the temperature rating of the lead, cord or cable, and contact with moving parts that may damage it, shall be prevented.

8.2.11 If external wiring passes into the luminaire, it shall comply with the appropriate requirements for internal wiring.

Compliance is checked by the tests of 8.3.

8.2.12 Fixed luminaires for looping-in shall be provided with terminals intended for maintaining the electrical continuity of supply cables feeding the luminaire, but not terminating in it.

Compliance is checked by inspection.

8.2.13 The ends of flexible stranded conductors may be tinned, but shall not have additional solder applied, unless a means is provided of ensuring that clamped connections cannot work loose owing to cold flow of the solder (see Figure 36).

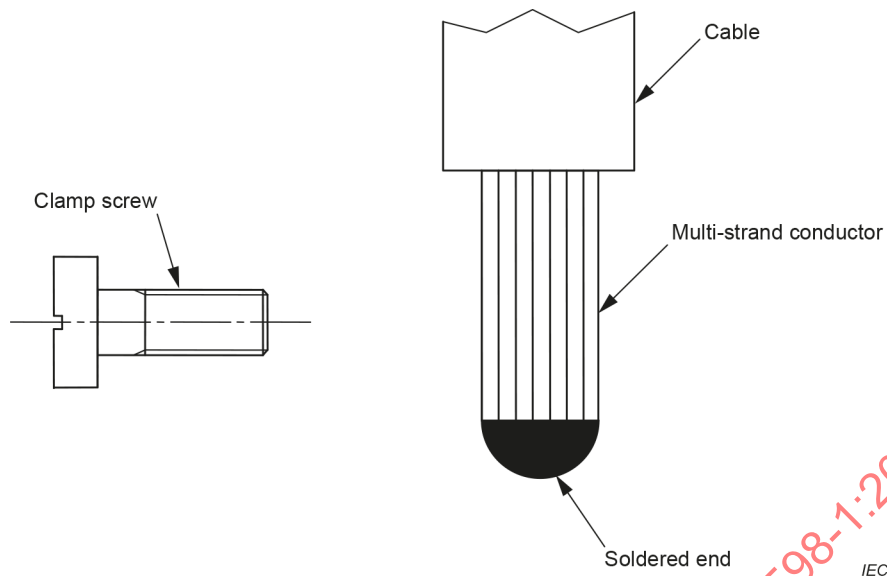

Figure 36 – Example of permitted degree of soldering

EXAMPLE This requirement is met when spring terminals are used. Securing the clamping screws is not an adequate means of preventing the connection of soldered strands from working loose owing to cold flow of the solder.

Compliance is checked by inspection.

8.2.14 If a plug is supplied with the luminaire by the manufacturer, the plug shall have the same degree of protection against electric shock and degree of protection against ingress of dust, solid objects and moisture as the luminaire.

Moulded-on type plugs are deemed suitable for the IP luminaire requirements on other than ordinary luminaires intended for domestic use.

NOTE 1 In some countries (e.g. United Kingdom and Australia), where national legislation requires the fitting of a certain plug which does not provide the required ingress protection, the luminaire manufacturer shall provide adequate instructions for connection to the supply ensuring an equivalent degree of protection against harmful ingress of dust and moisture as that provided by the luminaire.

A class III luminaire shall not be provided with a plug which permits any electrical connection with a socket-outlet in accordance with IEC TR 60083 or mains appliance outlets or connectors in accordance with the IEC 60320 series.

There shall be no unsafe compatibility between couplers for class II and class III with systems specified in the standard sheets of the IEC 60320 series and with the national domestic plug and socket-outlet systems of the country where the luminaire is placed on the market.

NOTE 2 For compliance with the above requirement, the manufacturer can provide the list of countries where the luminaire is placed on the market where no risk of unsafe plug-socket compatibility has been verified.

Compliance is checked by inspection and by the following test (see Figure 37).

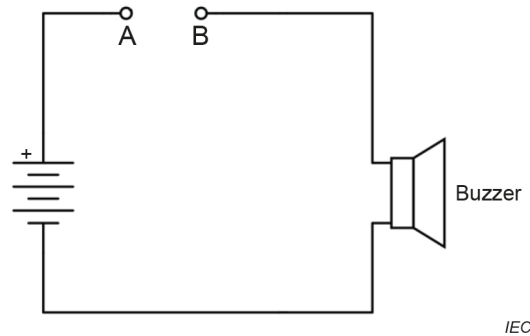

Figure 37 – Circuit for checking electrical contact between socket-outlet and plug

Pole A is connected to all contacts of the outlet and Pole B is connected to all contacts of the plug. During insertion the buzzer shall not operate.

NOTE 3 Some national plug and socket-outlet systems are shown in IEC TR 60083.

Plugs and socket-outlets for class III luminaires, where a safety isolating transformer is delivered with the luminaire having a rated current ≤ 3 A and a rated voltage ≤ 25 V AC or ≤ 60 V DC and a power not exceeding 72 W, are allowed to comply only with the following requirements:

- plugs shall not be able to make any electrical contact with socket-outlets of other voltage systems (in accordance with IEC TR 60083);
- sockets-outlets shall not admit plugs of other voltage systems;
- socket-outlets shall not have the protective earth contact.

For this particular plug and socket-outlet system, the ball pressure test given in Clause 15 is not applicable.

8.2.15 For Class III luminaires powered via information technology communication cabling, connection to the supply shall be made by means of connectors complying with the IEC 60603 series or the IEC 62680 series.

NOTE The given requirements for PoE are adapted from IEC 62368-3:2017.

Compliance is checked by inspection.

8.2.16 AC mains appliance inlets incorporated into luminaires to connect to the mains supply shall comply with the requirements of the IEC 60320 series. For fixed luminaires installation, couplers according to IEC 61535 may alternatively be used. In this case it shall be verified that conditions of use advised by the coupler manufacturer have been observed (IEC 61535:2023, 8.4).

NOTE The IEC 60320 series includes other configurations which do not comply with the relevant standard data sheet.

If connections or appliance inlet connector systems according to IEC 61984 are used in accordance with their intended use and ratings, the following requirements shall be applied:

a) Polarization

There shall be no unsafe compatibility between any pole of connectors, in accordance with IEC 61984:2008, 6.3.

b) Protection against electric shock

Enclosed connectors shall be used if the connector is accessible in normal use.

c) Mechanical locking

Connectors without a breaking capacity (COC), as defined in IEC 61984:2008, 3.9, shall be provided with mechanical locking between the socket-outlet and the plug. Locking devices, where the locking function can be enabled by hand are permitted. Connectors with a breaking capacity (CBC), as defined in IEC 61984:2008, 3.8, may be provided without a locking device.

d) Early contact making

Early contact making of a protective earth contact is also required for connectors designed with contacts making only in a no-load condition.

e) Protection against short-circuit of poles

If stranded wires are used, there shall be protection against an unintended short-circuit caused by a free strand. The test of IEC 61535:2023, 12.8.2 applies with a strand length of 6 mm insulation removed.

f) Cable clamp

Connectors for external wiring shall be provided with a cable clamp, in accordance with IEC 61984:2008, 6.17.

Compliance is checked by inspection.

8.2.17 Interconnecting cables, if not made of standardized insulated and sheathed cables, shall consist of a defined assembly made by the luminaire manufacturer of wiring within a sleeve, tube or equivalent construction.

8.2.18 All portable luminaires and fixed luminaires or luminaires intended to be connected to the supply via a socket-outlet, shall be fitted with a plug in accordance with IEC TR 60083, or with regional or national standards where applicable, appropriate to the classification of the luminaire.

Compliance is checked by inspection.

8.3 Internal wiring

8.3.1

8.3.1.1 Internal wiring shall be made with conductors of a suitable size and type to handle the power occurring during normal use. The insulation of the wiring shall be made of a material capable of withstanding the voltage and the maximum temperature to which it is subjected, without affecting the safety when properly installed and connected to the mains.

If cables with a common type of insulation (PVC or rubber) are used as through wiring, it is not necessary for these cables to be delivered with the luminaire if the way of mounting given in the manufacturer's instructions is clear. However, if special cables or sleeves, for example due to high temperatures, are necessary, the through wiring shall always be factory-assembled. The requirements of 6.4.4 c) shall be taken into account in the latter case.

Wires coloured with the green and yellow combination shall only be used for protective earth connections.

NOTE The temperature limits for the insulation are given in Table 22.

Sleeves in compliance with 7.9.2 are suitable to protect hot spots.

Compliance is checked by inspection and by the tests of Clause 14.

8.3.1.2 For wiring including connecting leads (tails) which is directly connected to the fixed wiring, for example via a terminal block, and where the disconnection from the mains is relied upon by the external protection device(s), the following is applicable.

For normal operating currents 2 A and higher:

- nominal cross-sectional area: minimum 0,5 mm²,
- for through-wiring of fixed luminaires: minimum 1,5 mm²,
- nominal insulation thickness: minimum 0,6 mm (PVC or rubber).

For mechanical protected wiring carrying normal operating currents lower than 2 A:

- nominal cross-sectional area: minimum 0,4 mm²,
- nominal insulation thickness: minimum 0,5 mm (PVC or rubber).

The required mechanical protection is regarded to be adequate when extra insulation is added at the following places where the wire insulation can be damaged:

- in small openings of pipes when, during production, the wires are slid through,
- when bending wires closely around metal not specially treated to produce smooth edges.

8.3.1.3 For wiring which is connected to the fixed wiring via an internal current-limiting device and limiting the current to 2 A maximum, for example lamp current control device, circuit cut-outs, fuses, protective impedance or isolating transformers, the following is applicable:

- the minimum cross-sectional area may be less than 0,4 mm² if overheating of the wire conductor insulation is prevented under normal and short-circuit operating conditions in accordance with the tests of 8.4;
- the minimum insulation thickness, which may be less than 0,5 mm (PVC or rubber), shall be selected in relation to the voltage stress occurring, see Table T.1;
- the current limit rating of the protection device shall be a proven characteristic of the device used.

NOTE See also 4.3.

8.3.1.4 In class II luminaires where the internal wiring has a hazardous live conductor and touches accessible metal parts under normal operating conditions, the insulation, at least at the places of contact, shall comply with the requirements for double or reinforced insulation relevant to the voltage stress, for example by applying sheathed cables or sleeves.

8.3.1.5 Conductors without insulation may be used provided that adequate precautions have been taken to ensure adherence to the creepage distances and clearance requirements of Clause 13 and also with regard to the class of protection of Clause 5.

8.3.1.6 The SELV or PELV current-carrying parts do not have to be insulated. However, if insulation is applied, they shall be tested as mentioned in Clause 12.

8.3.1.7 When insulation materials which have insulating or mechanical properties higher than PVC or rubber are used, an insulation thickness shall be selected which gives the same degree of protection against electric shock.

8.3.2 Internal wiring shall be so situated or protected that it cannot be damaged by sharp edges, rivets, screws and similar components, or by moving parts of switches, joints, raising and lowering devices, telescopic tubes and similar parts. Wiring shall not be twisted along the longitudinal axis of the cable through an angle exceeding 360°.

Compliance is checked by inspection (see also 7.14.4 and 7.14.5) and in accordance with the test of 7.14.3.

8.3.3 If in class II luminaires, in settable and adjustable luminaires, or in portable luminaires other than those for wall mounting, internal wiring passes through accessible metal parts or through metal parts in contact with accessible metal parts, the opening shall be provided with a tough bushing of insulating material, having smoothly rounded edges, so fixed that it cannot easily be removed. Bushings of material likely to deteriorate with age shall not be used in openings with sharp edges.

NOTE 1 The term "easily removable bushing" is used to describe a bushing which can be pulled out of its mounting by movement of the luminaire during its life or by inadvertent handling of the luminaire. Examples of accepted fixings include use of lock-nut, appropriate adhesive such as self-hardening resin, or properly sized push-fits.

NOTE 2 An example of materials known for deterioration with age is natural rubber.

If the cable entry openings have smoothly rounded edges and the internal wiring is not required to be moved in service, this requirement is met by the use of a separate protective sheath over a cable that has no special protective sheath, or by using a cable which incorporates a protective sheath.

8.3.4 Joints and junctions in internal wiring, excluding terminations on components, shall be provided with an insulating covering no less effective than the insulation of the wiring.

Compliance with the requirements of 8.3.3 and 8.3.4 is checked by inspection.

8.3.5 Where internal wiring passes out of the luminaire and the design is such that the wiring can be subject to strain, the requirements for external wiring apply. The requirements for external wiring do not apply to internal wiring of ordinary luminaires which has a length of less than 80 mm outside the luminaire. For luminaires which are other than ordinary, all wiring external to the enclosure shall comply with the external wiring requirements.

Compliance is checked by inspection, measurements and, if appropriate, in accordance with the tests and conditions of 8.2.10.2 or 8.2.10.5.

8.3.6 Wiring of settable and adjustable luminaires shall be fixed by means of wire carriers, clips or similar parts of insulating material at all places where it can otherwise rub against metal parts in the normal movement of the luminaire in such a way that the insulation can be damaged.

8.3.7 The ends of flexible stranded conductors may be tinned but shall not have additional solder applied unless a means is provided of ensuring that clamped connections cannot work loose owing to cold flow of the solder (see Figure 36).

EXAMPLE This requirement is met when spring terminals are used. Securing the clamping screws is not an adequate means of preventing the connecting of soldered strands from working loose owing to cold flow of the solder.

Compliance with the requirements of 8.3.6 and 8.3.7 is checked by inspection.

8.4 Test to determine the suitability of conductors having a reduced cross-sectional area

To determine the suitability of conductors having a reduced cross-sectional area, connected to controlgear that limits the current to 2 A, the following test shall be conducted:

- a) disconnect the conductors being evaluated as close as practical to the lights source in the luminaire and attach a resistive load using minimum 1 mm² cross-section test leads; these leads shall be routed out of the luminaire in a manner that will have the least impact on temperatures within the luminaire;
- b) adjust the resistive load to measure the maximum output current of the controlgear, maximum measured current shall not exceed 2 A;
- c) with the resistive load set to draw maximum output current, conduct the thermal test in accordance with 14.4 (see Figure 38);

d) the resistive load is then set to 0 Ω (short-circuit) and the thermal test repeated in accordance with 14.4 (see Figure 38);

In no case shall the temperature of the luminaire wiring insulation exceed the limits stated in Table 22 nor shall there be any indication of damage to the luminaire wiring.

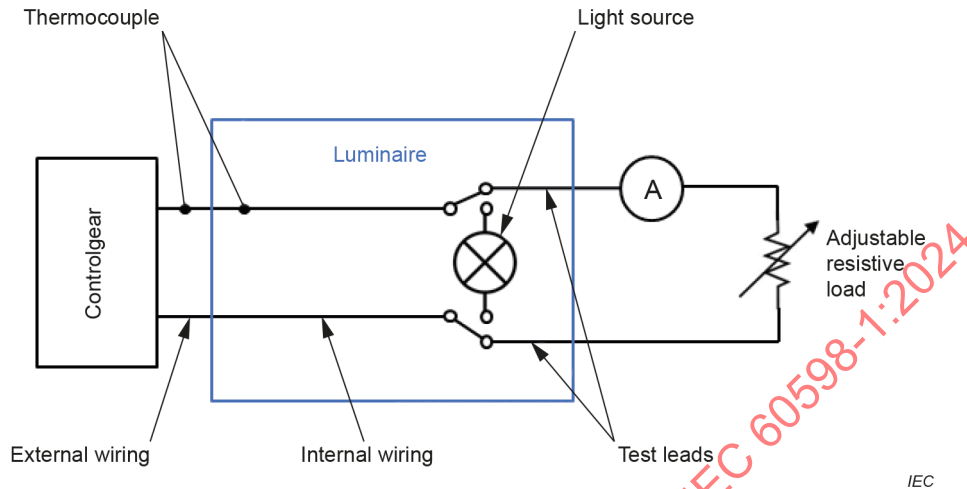

Resistive load is adjustable and capable of presenting low resistance (close to 0 Ω).

NOTE The controlgear can be internal to the luminaire.

Figure 38 – Test to determine the suitability of conductors having a reduced cross-sectional area

9 Provision for earthing

9.1 General

Clause 9 specifies the requirements, where applicable, for the earthing of luminaires.

9.2 Provision for earthing

9.2.1 Metal parts of class I luminaires which are accessible when the luminaire has been mounted, or is opened for replacement of a replaceable light source or replaceable starter or for cleaning purposes, and which can become hazardous live parts in the event of an insulation fault, shall be durably and reliably connected to a protective earthing terminal or protective earthing contact.

Metal parts screened from hazardous live parts by metal parts which are connected to the protective earthing terminal or protective earthing contact, and metal parts separated from hazardous live parts by double insulation or by reinforced insulation, are not, for the purpose of this requirement, regarded as likely to become hazardous live parts in the event of an insulation fault.

NOTE 1 If a lamp breaks during lamp replacement, the breakage is not regarded as an insulation fault according to 9.2.1, as the lamp in this sense is not considered to be a part of the luminaire (see 4.2.2 and 10.2.3, item a) for clarification).

Metal parts of luminaires which can become hazardous live parts in the event of an insulation fault and which are not accessible when the luminaire has been mounted, but are liable to come into contact with the mounting surface, shall be durably and reliably connected to a protective earthing terminal.

NOTE 2 The earthing of starters and lamp caps is not a requirement but earthing of lamp caps can be necessary as a starting aid.

The protective earthing connections shall be of low resistance.

Self-tapping screws may be used to provide protective earthing continuity, provided they comply with the requirements given in 7.12.1.

Thread-forming screws may be used to provide protective earthing.

A thread forming screw used in a groove of a metallic material provides protective earth continuity for a luminaire if all the tests required within this document regarding protective earthing connection are passed. See Figure 39.

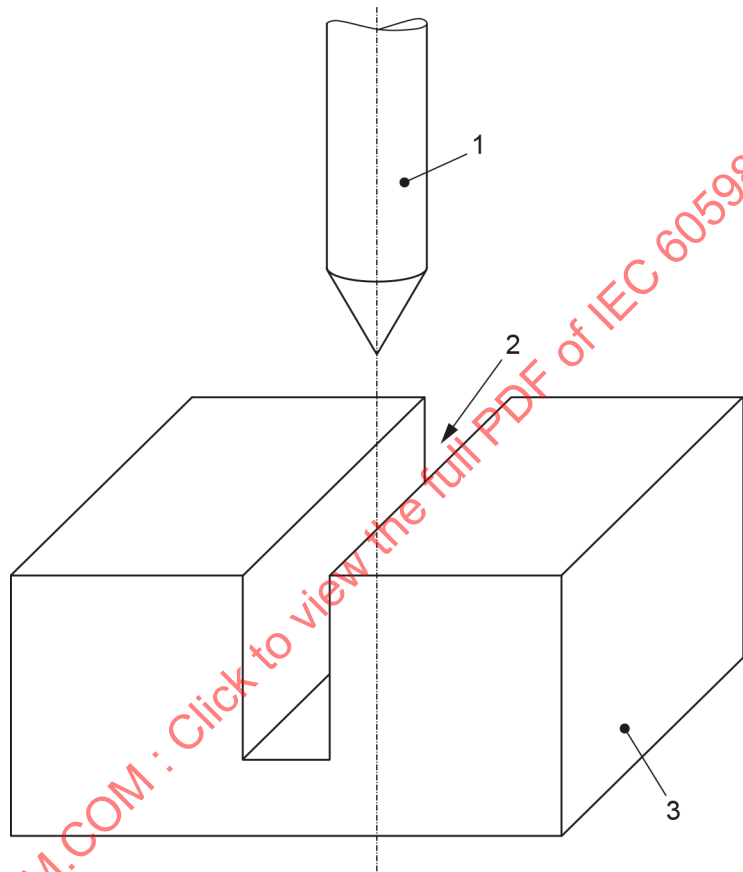

IEC

Key

- 1 thread-forming screw
- 2 groove
- 3 metallic material

Figure 39 – Example of a thread-forming screw used in a groove of a metallic material

For class I luminaires with detachable parts provided with connectors or similar connection devices, the protective earth connection shall be made before the current-carrying contacts are made and the current-carrying contacts shall separate before the protective earth connection is broken.

For terminal blocks with integrated screwless protective earthing contacts, the additional tests of Annex R shall be applied.

It is allowed to earth built-in controlgear by means of fixing the controlgear to earthed metal parts of the luminaire. The connection of protective earthing to the luminaire via the built-in controlgear is not allowed.

9.2.2 Surfaces in settable and adjustable joints, telescopic tubes, etc., providing protective earthing continuity, shall be such that a good electrical contact is ensured.

9.2.3 *Compliance with the requirements of 9.2.1 and 9.2.2 is checked by inspection and, for protective earth, by the following test.*

A current of at least 10 A, derived from a source with a no-load voltage not exceeding 12 V, shall be passed between the earthing terminal or earthing contact and each of the accessible metal parts in turn.

The voltage drop between the earthing terminal or earthing contact and the accessible metal part shall be measured and the resistance calculated from the current and the voltage drop. In no case shall the resistance exceed 0,5 Ω . When type testing, the current shall be applied for a period of at least 1 min.

NOTE In the case of a luminaire with a supply cord, the earthing contact is at the plug or supply end of the flexible cable or cord.

9.2.4 Protective earthing terminals shall comply with the requirements of 7.7.3. The connection shall be adequately locked against accidental loosening.

For screw terminals, it shall not be possible to loosen the clamping means by hand.

For screwless terminals, it shall not be possible to loosen the clamping means unintentionally.

Compliance is checked by inspection, by manual test and by the tests specified in 7.7.3.

NOTE In general, the designs commonly used for current-carrying terminals provide sufficient resilience to comply with this requirement; for other designs, special provisions, such as the use of an adequately resilient part which is not likely to be removed inadvertently, can be necessary.

For terminal blocks with integrated screwless protective earthing contacts, the additional tests of Annex R apply.

9.2.5 For a luminaire provided with a connector socket for a mains supply, the earth contact shall be an integral part of the socket.

9.2.6 For a luminaire to be connected to supply cables (fixed wiring) or to a supply cord, the earth terminal shall be adjacent to the mains terminal.

NOTE Luminaires can be provided with type X or type Y attachments.

9.2.7 For luminaires which are other than ordinary luminaires, all parts of a protective earth terminal shall be such as to minimize the danger of electrolytic corrosion resulting from contact with the earth conductor or any other metal in contact with them.

9.2.8 Either the screw or the other part of the protective earth terminal shall be made of brass or other non-rusting metal or a material with a non-rusting surface and the contact surfaces shall be of bare metal.

9.2.9 *Compliance with the requirements of 9.2.5 to 9.2.8 is checked by inspection and by manual test.*

9.2.10 If a fixed class II luminaire is provided with internal terminal(s) and circuits for maintaining the electrical continuity for looping-in or through wiring of a protective earth conductor, internal terminal(s) and circuits shall be insulated from hazardous live parts by basic insulation.

If a fixed connected class II luminaire has a functional earthing connection the functional earth circuit shall be separated from hazardous live parts by double or reinforced insulation.

Compliance is checked by inspection and by the relevant tests required for the insulation.

9.2.11 When a class I luminaire is supplied with a supply cord, this cord shall have an earthing core coloured green-yellow.

The green-yellow core of a supply cord shall be connected to the protective earthing terminal of the luminaire and to the earthing contact of the plug if one is attached.

All conductors, whether internal or external, which are identified by the green and yellow colour combination shall only be connected to a protective earthing terminal.

For luminaires with supply cords, the arrangement of the terminals, or the length of the conductors between the cord anchorage and the terminals, shall be such that should the cable or cord move out of the cord anchorage, the current-carrying conductor becomes taut before the protective earthing conductor.

Compliance is checked by inspection.

9.2.12 Where a PELV circuit is connected to a protective earth for functional purposes, this circuit shall not be used for interconnection with other luminaires to avoid overload of the circuit conductor.

NOTE The overload of the conductor can be caused by a fault current coming from a different point of the earth circuit of a building to earth.

10 Protection against electric shock

10.1 General

Clause 10 specifies requirements for protection against electric shock from luminaires. A test to determine whether a conductive part is a hazardous live part which can cause an electric shock is described in Annex A.

10.2 Protection against electric shock

10.2.1 Luminaires shall be so constructed that their hazardous live parts are not accessible when the luminaire has been installed and wired as in normal use, and when it is opened as necessary for replacing replaceable light sources; or for access to other serviceable components, even if the operation cannot be achieved by hand. Basic insulated parts shall not be used on the outer surface of the luminaire without appropriate protection against accidental contact.

NOTE 1 Examples of basic insulated parts are cables intended for internal wiring, controlgear for building-in.

Where a protective cover is used over a non-user replaceable light source or non-user serviceable component in accordance with 7.30, the cover shall be left in place during the tests and inspections detailed by Clause 10. For serviceable components other than lamps all operations that are necessary to replace the component (including disconnection and re-connection) and all operations that are required to adjust or set the components shall not give access to hazardous live parts.

No access to hazardous live parts with the standard test finger (test probe B according to IEC 61032:1997, Figure 2) is permitted when the assembled luminaire has been installed as for normal use and, in addition, under the following conditions:

- for portable, settable and adjustable luminaires, no access to basic insulated parts with the standard test finger (test probe B according to IEC 61032:1997, Figure 2) is permitted, and
- for other types of luminaires, there shall be no access to basic insulated parts from the outside of the luminaire by means of a 50 mm diameter probe according to IEC 61032:1997, Figure 1.

Lampholders and starterholders, if used in portable, settable and adjustable luminaires and if accessible as specified above, shall comply with the electrical strength test and creepage distance and clearance requirements for double or reinforced insulation.

NOTE 2 Sufficient creepage distances and clearances to outer accessible surfaces can often only be achieved after mounting into the luminaire.

NOTE 3 Information on lampholders and starterholders complying with the above requirements can be taken from the manufacturer's literature.

Basic insulation may be accessible when the luminaire is opened for light source or starter replacement or for accessing serviceable components.

If a component intended for building-in is used on the outside of a fully assembled luminaire which can be touched by the 50 mm sphere, it shall comply with the relevant requirements applied to an independent component (see 3.32).

Other than where specifically required, lamps, lampholders and starterholders complying with their own standard are exempt from the requirements of 10.2.1.

Protection against electric shock shall be maintained for all methods and positions of installation in normal use with regard to the limitations indicated in the manufacturer's installation instructions, and for all adjustments of settable and adjustable luminaires. Protection shall be maintained after removal of all parts which can be removed by hand, except lamps and the following parts of the lampholders:

- a) For bayonet lampholders:
 - 1) domes (terminal covers);
 - 2) skirts.
- b) For Edison screw lampholders:
 - 1) domes (terminal covers) for cord grip types only;
 - 2) outer shells.

Covers in fixed luminaires that cannot be removed by a single action with one hand are not removed. However, covers which have to be removed for changing light sources and to access serviceable components (except for non-user replaceable light sources and components and non-replaceable light sources and components) or starters, are removed for this test.

NOTE 4 A single action with one hand is normally taken to include removal of items such as a knurled headed screw or a shade retaining ring.

Supply conductors held by screwless terminals with push-button releasing devices shall not be removed for this test.

The use of push-button type terminal blocks without the use of a cover is not precluded by this requirement. This is possible as some specific actions are required in order to release wiring from these blocks.

Class I and class II luminaires intended for tubular tungsten filament lamps, or equivalent lamp replacing these having a cap/base at each end, shall incorporate a means of automatic double-pole disconnection operative when the lamp is being changed. This requirement does not apply if the relevant cap and holder combination(s) is (are) covered by standards which incorporate special requirements with regard to accessibility of hazardous live parts which can cause an electric shock.

The insulating properties of lacquer, enamel, paper and similar materials shall not be relied upon to give the required protection against electric shock and protection against short-circuit.

Luminaires with ignitors intended for use with double ended high pressure discharge lamps shall be tested according to Figure 19.

If the voltage measured according to Figure 19 exceeds 34 V (peak), the ignitor shall only be active if the lamp is fully inserted, or a warning according to 6.3.18 a) or b) respectively shall be fitted to the luminaire.

Luminaires for double-capped Fa8 tubular lamps shall comply with the marking requirement of 6.3.18.

10.2.2 For portable luminaires, protection against electric shock shall also be maintained after movable parts of the luminaires have been placed in the most unfavourable position, which can be effected by hand.

10.2.3 For protection against electric shock, the following additional requirements apply:

a) Metal parts of class II luminaires which are insulated from hazardous live parts by basic insulation only are hazardous live parts for the purpose of Clause 10. Subclause 10.2 is applicable for the situations where no electrical insulation is provided between the mains supply and output circuits of the controlgear. Where the controlgear provides basic or double or reinforced insulation from the mains supply the required insulation from the hazardous live part to the accessible part shall comply with Table T.1.

This does not apply to the non-current carrying parts of caps which comply with their relevant IEC safety standard.

For class II luminaires, glass lamp bulbs are not regarded as having further protection against electric shock. If glass bowls and other protective glasses have to be removed when the lamp is replaced or if they do not withstand the test of 7.13, they shall not be used as supplementary insulation.

b) Metal lamp holders for bayonet cap lamps in class I luminaires shall be connected to a protective earth.

c) SELV circuits may have exposed current carrying parts under the following conditions.

– For ordinary luminaires:

- the no-load voltage and the voltage under load, does not exceed
 - for AC circuits: 25 V RMS;
 - for DC circuits: 60 V ripple free;
 - for interrupted DC voltage for frequencies between 10 Hz and 200 Hz: 25 V peak;
- where the voltage exceeds 25 V AC RMS or 60 V ripple free DC, the touch current does not exceed:
 - for AC circuits: 0,7 mA (peak);
 - for DC circuits: 2,0 mA (non-interrupted DC only);
 - for interrupted DC circuits ($f < 10$ Hz or $f > 200$ Hz): 0,7 mA (peak);
 - for interrupted DC circuits (10 Hz $\leq f \leq 200$ Hz): 0,41 mA (peak);

If the voltages or currents exceed the values given above, at least one of the conductive poles in the SELV circuit shall be insulated by insulation capable of withstanding a test voltage of 500 V RMS for 1 min.

- For luminaires which are other than ordinary, the nominal voltage (under load and under no load) does not exceed 12 V RMS or 30 V ripple free DC or 12 V peak interrupted DC voltage for frequencies between 10 Hz and 200 Hz. When the luminaire is opened for light source replacement, the voltage limits for ordinary luminaires are applicable (for parts only accessible during maintenance).

d) PELV circuits may have exposed current carrying parts under the following conditions:

- for ordinary luminaires the voltage under load and under no load does not exceed 12 V RMS or 30 V ripple free DC;
- for luminaires which are other than ordinary, the voltage (under load and under no load) does not exceed 12 V RMS or 30 V ripple free DC.

If the voltages exceed the values given above in the PELV circuit, only the pole connected to earth may be accessible. The other pole shall be protected by an insulation capable of withstanding a test voltage of 500 V RMS for 1 min in accordance with 12.2.3.

NOTE These limits are based on IEC 60364-4-41. See also Annex A.

Class III luminaires are accepted only for connection to a SELV source or PELV source.

10.2.4 Portable luminaires for connection to the supply by means of a supply cord and plug shall have protection against electric shock which is independent of the mounting surface.

10.2.5 *Compliance with the requirements of 10.2.1 to 10.2.4 is checked by inspection and, if necessary, by the test with the relevant test probe according to IEC 61032:1997, Figure 1 and Figure 2 or by means of the specific test probe specified for the component in question.*

This test probe shall be applied to every possible position, if necessary with a force of 10 N, an electrical indicator being used to show contact with hazardous live parts. Movable parts, including shades, shall be placed in the most unfavourable position by hand; if made of metal, they shall not touch hazardous live parts of the luminaire or of the lamps.

10.2.6 Covers and other parts providing protection against electric shock shall have adequate mechanical strength and shall be reliably secured so that they will not work loose with normal handling.

Compliance is checked by inspection, by manual test and by the tests of Clause 7.

For wall-mounted luminaires, portable, settable and adjustable luminaires where covers whose fixing is not dependent on screws and whose removal is obtained by applying a force in an approximately perpendicular direction to the mounting surface, shall comply with the following test:

A force is applied approximately perpendicular to the mounting surface. The force shall be 20 N when the opening of the cover gives access to basic insulated parts and 80 N when hazardous live parts are accessible.

During the test, the cover(s) shall not work loose.

10.2.7 Luminaires (other than those mentioned below) incorporating a capacitor of capacitance exceeding 0,5 μF shall be provided with a discharge device so that the voltage across the capacitor 1 min after disconnection of the luminaire from the source of supply at rated voltage does not exceed 50 V.

Portable luminaires designed to be connected to the supply by means of a plug, track adaptor connected luminaires, or luminaires with supply connector with contacts accessible with the standard test finger (test probe B according to IEC 61032:1997, Figure 2) and incorporating a capacitor of capacitance exceeding 0,1 μF (or 0,25 μF for luminaires with a rated voltage less than 150 V) shall be provided with a discharge device so that 1 s after disconnection, the voltage between the pins of the plug or adaptor or connector contacts does not exceed 34 V.

Other luminaires connected to the supply by means of a plug and incorporating a capacitor exceeding 0,1 μF (or 0,25 μF for luminaires of rated voltage less than 150 V) and track adaptors mounted in luminaires shall discharge so that after 5 s, the voltage between the pins of the plug does not exceed 60 V RMS.

Subclause 4.2.2 requires that the tests of this document shall be conducted without the lamp in circuit, unless otherwise specified. In the case of this Subclause 10.2.7, the lamp shall be in circuit when the measurement of the voltage from the capacitor is made, if it leads to a more onerous result.

The residual voltages referred to in this requirement shall be measured on only one luminaire, even if it is envisaged that such a luminaire may be installed in a multiple luminaire system.

Compliance is checked by measurement.

NOTE The discharge device (for all types of luminaire) can be incorporated on or within the capacitor or mounted separately within the luminaire.

11 Resistance to dust, solid objects and moisture

11.1 General

Clause 11 specifies the requirements and tests for luminaires classified as resistant to dust, solid objects and moisture in accordance with Clause 5, including ordinary luminaires.

11.2 General conditions and tests for IP classification

11.2.1 General

The enclosure of a luminaire shall provide the degree of protection against ingress of dust, solid objects and moisture in accordance with the classification of the luminaire and the IP number marked on the luminaire.

NOTE 1 The tests for the ingress of dust, solid objects and moisture specified in this document are not all identical to the tests in IEC 60529 because of the technical characteristics of luminaires. An explanation of the IP numbering system is given in Annex H.

Compliance is checked by the appropriate tests specified in 11.2.2 to 11.2.13, and for other IP ratings by the appropriate tests specified in IEC 60529.

Before the tests for the second characteristic numeral, with the exception of IPX8, the luminaire complete with lamp(s) shall be switched on and brought to a stable operating temperature at rated voltage.

The water for the tests shall be at a temperature of 15 °C \pm 10 °C except for IPX9 where the temperature shall be 80 °C (\pm 5 °C) or 15 °C (\pm 10 °C) following the marking of the luminaire.

Luminaires shall be mounted and wired as in normal use and placed in the most unfavourable position, complete with their protective translucent covers, if any, for the tests of 11.2.2 to 11.2.13.

Where connection is made by a plug or a similar device, then this shall be regarded as part of the complete luminaire and shall be included in the tests and similarly for any separate controlgear.

For the tests of 11.2.5 to 11.2.13, a fixed luminaire intended for mounting with its body in contact with a surface shall be tested with an expanded metal spacer interposed between the luminaire and the mounting surface. The spacer shall be at least equal in overall size to the luminaire perimeter in contact with the mounting surface, and have dimensions as follows:

longway of mesh	10 mm to 20 mm;
shortway of mesh	4 mm to 7 mm;
strand width	1,5 mm to 2 mm;
strand thickness	0,3 mm to 0,5 mm;
overall thickness	1,8 mm to 3 mm.

Luminaires having provision for draining water by means of drain holes shall be mounted with the lowest drain hole open unless otherwise specified in the manufacturer's installation instructions.

If the installation instructions indicate that a luminaire is for ceiling, wall or under-canopy mounting, the luminaire shall be attached to a flat board or plate which extends 10 mm beyond that part of the luminaire perimeter in contact with the mounting surface.

For IP2X luminaires, the enclosure denotes that part of the luminaire containing the main part other than the lamp and optical controls.

NOTE 2 Since luminaires have no hazardous moving parts, the level of safety as specified in IEC 60529 is achieved.

Portable luminaires, wired as in normal use, shall be placed in the most unfavourable position of normal use.

Glands, if any, shall be tightened with a torque equal to two-thirds of that applied to glands in the test of 7.12.4.

Fixing screws of covers, other than hand-operated fixing screws of glass covers, shall be tightened with a torque equal to two-thirds of that specified in Table 5.

Screwed lids shall be tightened with a torque having a value in newton metres numerically equal to one-tenth of the nominal diameter of the screw thread in millimetres. Screws fixing other caps shall be tightened with a torque equal to two-thirds of that specified in Table 5.

After completion of the tests, the luminaire shall withstand the electric strength test specified in Clause 12, and inspection shall show:

- a) *no deposit of talcum powder in dust-proof luminaires, such that, if the powder were conductive, the insulation would fail to meet the requirements of this document;*
- b) *no deposit of talcum powder inside enclosures for dust-tight luminaires;*
- c) *no trace of water on electrical connections, current carrying parts or on insulation where it can become a hazard for the user or surroundings, for example where it can reduce the creepage distances below the values specified in Clause 13; the only exception to this is for SELV or PELV conductors where the voltage under load does not exceed 12 V peak interrupted DC voltage for frequencies between 10 Hz and 200 Hz, 12 V RMS or 30 V ripple free DC and the conductors are protected from corrosion.*

NOTE 3 Some aspects of protection against corrosion are covered by 7.18.

- 1) *For luminaires without drain holes, there shall be no water entry.*

NOTE 4 Care is taken not to mistake condensation for water entry.

- 2) *For luminaires with drain holes, water entry including condensation is allowed during the tests if it can drain out effectively and provided it does not reduce the creepage and clearance distances below the minimum levels specified in this document;*
- d) *no trace of water having entered in any part of a watertight or pressure watertight luminaire or high pressure and temperature water jet-proof luminaire or high pressure and cold water jet-proof luminaire;*
- e) *no contact permitted with hazardous live parts by the relevant test probe for first characteristic IP numeral 2;*
no entry into the luminaire enclosure by the relevant test probe for first characteristic IP numerals 3 and 4;
for luminaires with drain holes in accordance with 7.17 and luminaires with ventilation slots for forced cooling, no contact with hazardous live parts is permitted through the drain holes and ventilation slots with the relevant test probe for the first characteristic IP numerals 3 and 4;
- f) *no trace of water on any part of a lamp requiring protection from splashing water as indicated in the "information for luminaire design" of the applicable lamp standard;*
- g) *no damage, for example, cracking or breakage of a protective shield or glass envelope, such that safety or protection against the ingress of moisture is impaired.*

11.2.2 Tests for first characteristics IP numerals 2, 3 and 4

Solid-object-proof luminaires (first characteristic IP numeral 2) shall be tested with the standard test finger (test probe B according to IEC 61032:1997, Figure 2) in accordance with the requirements of Clause 10 and Clause 13.

Luminaires with first characteristic IP numeral 2 are not required to be tested with the sphere specified in IEC 60529.

Solid-object-proof luminaires (first characteristic IP numerals 3 and 4) shall be tested at every possible point (excluding gaskets) with a probe in accordance with test probe C or D of IEC 61032, applied with a force as specified in Table 14.

Table 14 – Solid-object-proof luminaire test

	Test probe according to IEC 61032	Probe wire diameter	Application force N
First IP numeral 3	C	2,5 mm $\begin{smallmatrix} +0,05 \\ 0,00 \end{smallmatrix}$ mm	3 with a tolerance of ± 10 %
First IP numeral 4	D	1 mm $\begin{smallmatrix} +0,05 \\ 0,00 \end{smallmatrix}$ mm	1 with a tolerance of ± 10 %

The end of the probe wire shall be cut at right angles to its length and be free from burrs.

11.2.3 Tests for first characteristic IP numeral 5 and 6

Dust-proof luminaires (first characteristic IP numeral 5) and dust-tight luminaires (first characteristic IP numeral 6) shall be tested in a dust chamber similar to that shown in Figure 40, in which talcum powder is maintained in suspension by an air current. The chamber shall contain 2 kg of powder for every cubic metre of its volume. The talcum powder used shall be able to pass through a square-meshed sieve whose nominal wire diameter is 50 μm and whose nominal free distance between wires is 75 μm . It shall not have been used for more than 20 tests.

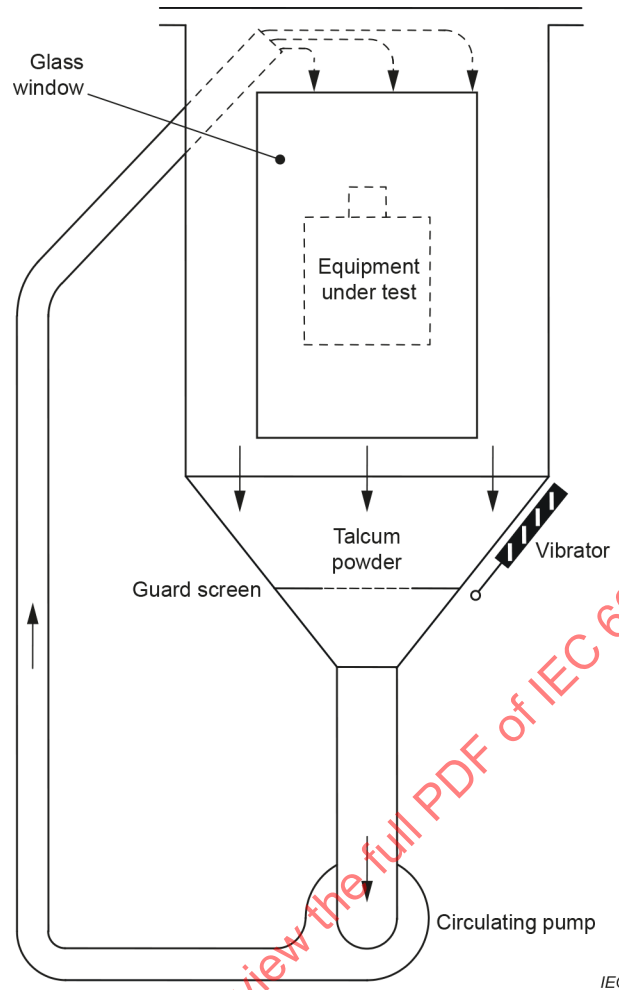

Figure 40 – Apparatus for proving protection against dust

The test shall proceed as follows.

- a) The luminaire is suspended outside the dust chamber and operated at rated supply voltage until the operating temperature is achieved.
- b) The luminaire, whilst still operating, is placed with the minimum disturbance in the dust chamber.
- c) The door of the dust chamber is closed.
- d) The fan or blower causing the talcum powder to be in suspension is switched on.
- e) After 1 min, the luminaire is switched off and allowed to cool for 3 h whilst the talcum powder remains in suspension.

NOTE The 1 min interval between switching on the fan or blower and switching off the luminaire is to ensure that the talcum powder is properly in suspension around the luminaire during initial cooling, which is most important with smaller luminaires. The luminaire is operated initially as in item a) to ensure the test chamber is not overheated.

11.2.4 Drip-proof luminaires – Tests for second characteristic IP numeral 1

Drip-proof luminaires (second characteristic IP numeral 1) are subjected for 10 min to an artificial rainfall of $1^{0.5}_0$ mm/min, falling vertically from a height of 200 mm above the top of the luminaire.

11.2.5 Drip-proof luminaires – Tests for second characteristic IP numeral 2

Drip-proof luminaires (second characteristic IP numeral 2) are subjected for 10 min to an artificial rainfall of $3^{+0.5}_0$ mm/min, falling vertically from a height of 200 mm above the top of the luminaire, when the luminaire is in the most onerous position and tilted at any angle up to 15° on either side of the vertical.

11.2.6 Rain-proof luminaires – Tests for second characteristic IP numeral 3

Rain-proof luminaires (second characteristic IP numeral 3) are sprayed with water for 10 min by means of a spray apparatus as shown in Figure 41. The radius of the semi-circular tube shall be as small as possible and compatible with the size and position of the luminaire.

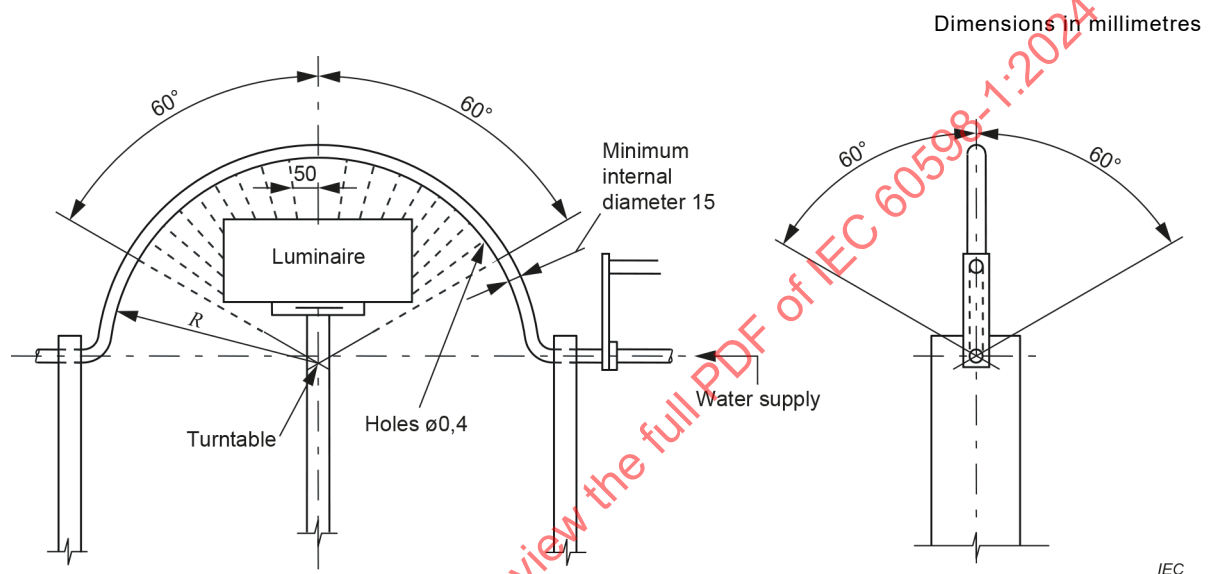

	Luminaire protection	
	Rain-proof	Splash-proof
Oscillation half-angle	$\pm 60^\circ$	$\pm 180^\circ$
Holes within half-angle	$\pm 60^\circ$	$\pm 90^\circ$

Figure 41 – Apparatus for testing protection against rain and splashing

The tube shall be perforated so that jets of water are directed towards the centre of the circle and the water flow rate at the inlet of the apparatus shall be approximately 0,07 l/min with a tolerance of $\pm 5\%$ per hole multiplied by the number of holes (approximately 80 kN/m²).

The tube shall be caused to oscillate through an angle of 120° , 60° on either side of the vertical, the time for one complete oscillation ($2 \times 120^\circ$) being about 4 s.

The luminaire shall be mounted above the pivot line of the tube so that the ends of the luminaire receive adequate coverage from the jets. The luminaire shall be turned about its vertical axis during the test at a rate of 1 r/min.

After this 10 min period, the luminaire shall be switched off and allowed to cool naturally whilst the water spray is continued for a further 10 min.

NOTE In Japan, the oscillating tube test and the spray nozzle test as specified in IEC 60529 are accepted.

11.2.7 Splash-proof luminaires – Tests for second characteristic IP numeral 4

Splash-proof luminaires (second characteristic IP numeral 4) are sprayed from every direction with water for 10 min by means of the spray apparatus shown in Figure 41 and described in 11.2.7. The luminaire shall be mounted central to the pivot line of the tube so that the ends of the luminaire receive adequate coverage from the jets.

The tube shall be caused to oscillate through an angle of almost 360°, 180° on either side of the vertical, the time for one complete oscillation ($2 \times 360^\circ$) being about 12 s. The luminaire shall be turned about its vertical axis during the test at a rate of 1 r/min.

The support for the equipment under test shall be grid shaped in order to avoid acting as a baffle. After this 10 min period, the luminaire shall be switched off and allowed to cool naturally whilst the water spray is continued for a further 10 min.

NOTE In Japan, the oscillating tube test and the spray nozzle test as specified in IEC 60529 are accepted.

11.2.8 Jet-proof luminaires – Tests for second characteristic IP numeral 5

Jet-proof luminaires (second characteristic IP numeral 5) are switched off and immediately subjected to a water jet for 15 min from all directions by means of a hose having a nozzle with the shape and dimensions shown in Figure 42. The nozzle shall be held 3 m away from the sample.

IECNORM.COM : Click to view the full PDF of IEC 60598-1:2024

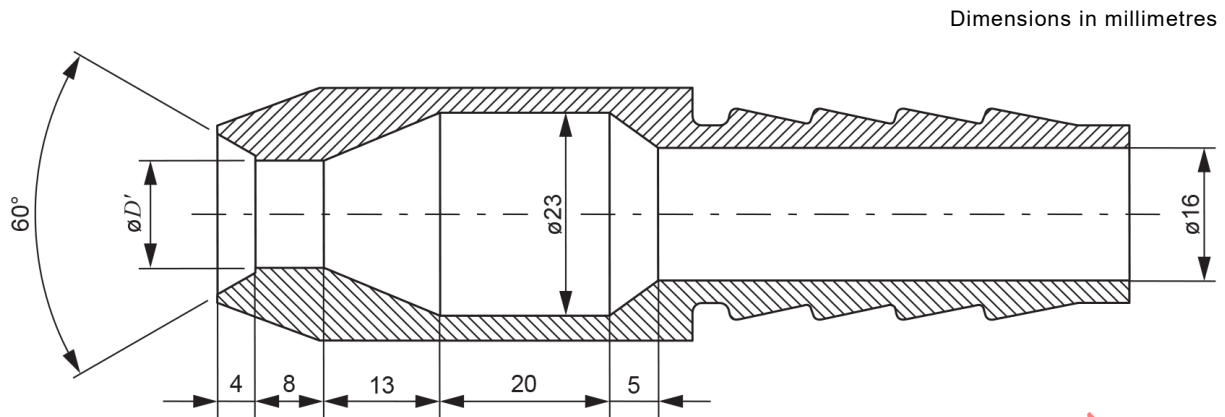

$D' = 6,3$ mm for the test of 11.2.8 (second characteristic numeral 5)
 $D' = 12,5$ mm for the test of 11.2.9 (second characteristic numeral 6)

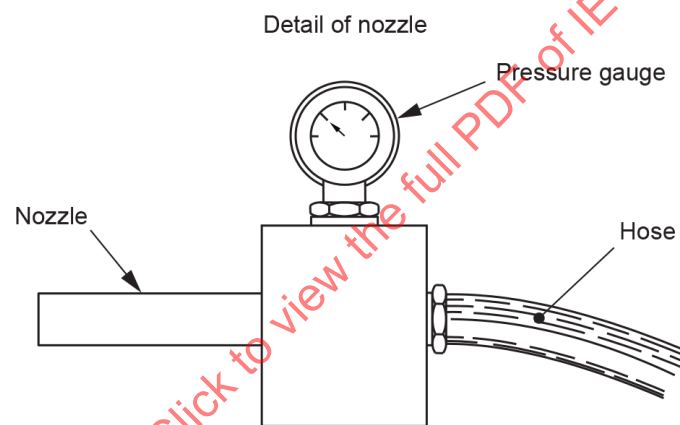

IEC

Figure 42 – Nozzle for spray test

The water pressure at the nozzle shall be adjusted to achieve a water flow rate of 12,5 l/min with a tolerance of ± 5 % (approximately 30 kN/m²).

11.2.9 Powerful jet-proof luminaires – Tests for second characteristic IP numeral 6

Powerful water jet-proof luminaires (second characteristic IP numeral 6) are switched off and immediately subjected to a water jet for 3 min from all directions by means of a hose having a nozzle with the shape and dimensions shown in Figure 42. The nozzle shall be held 3 m away from the sample.

The water pressure at the nozzle shall be adjusted to achieve a water flow rate of 100 l/min with a tolerance of ± 5 % (approximately 100 kN/m²).

11.2.10 Watertight luminaires – Tests for second characteristic IP numeral 7

Watertight luminaires (second characteristic IP numeral 7) are switched off and immediately immersed for 30 min in water, so that there is at least 150 mm of water above the top of the luminaire and the lowest portion is subjected to at least a 1 m head of water. Luminaires shall be held in position by their normal fixing means. Luminaires for tubular fluorescent lamps shall be positioned horizontally, with the diffuser upwards, 1 m below the water surface.

NOTE This treatment is not sufficiently severe for luminaires intended for operation under water.

11.2.11 Pressure watertight luminaires – Tests for second characteristic IP numeral 8

Pressure watertight luminaires (second characteristic IP numeral 8) are heated either by switching on the lamp or by other suitable means, so that the temperature of the luminaire enclosure exceeds that of the water in the test tank by between 5 °C and 10 °C.

The luminaire shall then be switched off and subjected to a water pressure of 1,3 times that pressure which corresponds to the rated maximum immersion depth for a period of 30 min.

11.2.12 High pressure and temperature water jet-proof luminaires – Tests for second characteristic IP numeral 9 (80 °C)

High pressure and temperature water jet-proof luminaires (second characteristic IP numeral 9 (80 °C)) are switched off and immediately subjected to the high pressure and high temperature water jet. The test is made by spraying the luminaire with a stream of hot water from a standard test nozzle as described in IEC 60529. The water for the tests shall be at a temperature of (80 ± 5) °C. For small enclosures (largest dimension less than 250 mm), the test duration is in total 2 min. For large enclosures (largest dimension greater than or equal to 250 mm), the test duration is 1 min/m² of the calculated surface area of the enclosure (excluding any mounting surface), with a minimum duration of 3 min.

11.2.13 High pressure and cold water jet-proof luminaires – Tests for second characteristic IP numeral 9 (15 °C)

High pressure and cold water jet-proof luminaires (second characteristic IP numeral 9 (15 °C)) are switched off and immediately subjected to the high pressure and cold temperature water jet. The test is made by spraying the luminaire with a stream of water from a standard test nozzle as described in IEC 60529. The water for the tests shall be at a temperature of (15 ± 10) °C. For small enclosures (largest dimension less than 250 mm), the test duration is in total 2 min. For large enclosures (largest dimension greater than or equal to 250 mm), the test duration is 1 min/m² of the calculated surface area of the enclosure (excluding any mounting surface), with a minimum duration of 3 min.

11.3 Humidity test

11.3.1 All luminaires shall be humidity-proof where humid conditions can occur in normal use.

Compliance is checked by the humidity treatment described in 11.3.2, followed immediately by the tests of Clause 12.

Cable entries, if any, shall be left open; if knock-outs are provided, one of them shall be opened.

Parts which can be removed by hand (e.g. electrical components, covers, protective glasses), shall be removed and subjected, if necessary, to the humidity treatment with the main part.

11.3.2 *The luminaire is placed in the most unfavourable position of normal use, in a humidity cabinet containing air with a relative humidity maintained between 91 % and 95 %. The temperature of the air at all places where samples can be located shall be maintained within 1 °C of any convenient value "t" between 20 °C and 30 °C.*

Before being placed in the humidity cabinet, the sample shall be brought to a temperature between "t" and (t + 4) °C. The sample shall be kept in the cabinet for 48 h.

NOTE In most cases, the sample can be brought to the specified temperature between "t" and (t + 4) °C by keeping it in a room at this temperature for at least 4 h before the humidity treatment.

In order to achieve the specified conditions within the cabinet, it is necessary to ensure constant circulation of the air within, and in general to use a cabinet which is thermally insulated.

After this treatment, the sample shall show no damage affecting compliance with the requirements of this document.

12 Insulation resistance and electric strength, touch current and protective conductor current

12.1 General

Clause 12 specifies requirements and tests for the insulation resistance, electric strength, touch current and protective conductor current of luminaires.

12.2 Insulation resistance and electric strength

12.2.1 General

The insulation resistance and the electric strength of luminaires shall be adequate.

Compliance is checked by the tests of 12.2.2 and 12.2.3 in the humidity cabinet or the room in which the sample was brought to the specified temperature, after reassembly of those parts which may have been removed.

The switch, if any, shall be placed in the ON position for all tests, except for tests between live parts which are separated by the action of a switch.

During these tests, the following components shall be disconnected, so that the test voltages are applied to the insulation of the components, but not to the capacitive or inductive functional elements of these components, as appropriate:

- a) *shunt-connected capacitors;*
- b) *capacitors between live parts and the body;*
- c) *protective impedance device;*
- d) *chokes or transformers connected between live parts;*
- e) *overvoltage protective devices in accordance with 7.32.*

If it is impossible to place metal foil in position on linings or barriers, the tests shall be made on three pieces of the lining or barrier which have been taken out and placed between two metal balls having a diameter of 20 mm, which shall be pressed together with a force of $2\text{ N} \pm 0,5\text{ N}$.

The conditions of test for controlgear shall be as specified in the IEC 61347 series.

The insulation between live parts and the body, as well as between accessible metal parts and metal foil on the inside of insulating linings and barriers, are tested according to the required type of insulation.

NOTE The term "body" includes the accessible metal parts, accessible fixing screws and metal foil in contact with the accessible parts of insulating material.

When carrying out the electric strength test on luminaires containing electronic controlgear, rated lamp circuit voltages greater than the luminaire supply voltage rating can be present. This is indicated by the rating U_{out} marked on the controlgear. In these instances, the test voltage applied to parts of the lamp circuit shall be calculated from the U_{out} rating instead of U , where U is the working voltage.

12.2.2 Test – Insulation resistance

The insulation resistance shall be measured with a DC voltage of approximately 500 V, 1 min after the application of the voltage.

For the insulation of SELV or PELV parts of luminaires, the DC voltage to be used for measurement is 100 V.

The insulation resistance shall be not less than the values specified in Table 15.

The insulation between hazardous live parts and the body of class II luminaires shall not be tested if the basic insulation and the supplementary insulation can be tested separately.

Table 15 – Minimum insulation resistance

Insulation of parts	Minimum insulation resistance		
	MΩ		
	Class I luminaires	Class II luminaires	Class III luminaires
SELV/PELV:			
Between current-carrying parts of different polarity	A	A	A
Between current-carrying parts and the mounting surface ^a	A	A	A
Between current-carrying parts and metal parts of the luminaire ^c	A	A	A
Between the outer surface of a flexible cord or cable where it is clamped in a cord anchorage and accessible metal parts	A	A	A
Insulating bushings as described in Clause 8	A	A	A
Other than SELV/PELV:			
Between hazardous live parts of different polarity	B	B	-
Between hazardous live parts and the mounting surface ^a	B	B and C, or D	-
Between hazardous live parts and metal parts of the luminaire	B	B and C, or D	-
Between hazardous live parts which can become of different polarity through action of a switch	B ^b	B ^b	-
Between the outer surface of a flexible cord or cable where it is clamped in a cord anchorage and accessible metal parts	B	C	-
Insulating bushings as described in Clause 8	B	C	-
A Basic insulation for voltages of SELV/PELV	1		
B Basic insulation for voltages other than SELV/PELV	2		
C Supplementary insulation	2		
D Double or reinforced insulation	4		

- ^a The mounting surface is covered with metal foil for the purpose of this test.
- ^b During the test, the switch can influence the result. In the case of electronic disconnection according to IEC 61058-1:2016, 7.14.1 or micro disconnection according to IEC 61058-1:2016, 7.14.2, it can be necessary to remove the switch from the circuit.
- ^c This requirement does not exclude the connection of the PELV circuits to earth for functional purposes.

Insulating linings and barriers shall be tested only if the distance between live parts and accessible metal parts, without the lining or barrier, would be less than that specified in Clause 13.

The insulation of bushings, cord anchorages, wire carriers or clips shall be tested in accordance with Table 15 and, during the test, the cable or cord shall be covered by metal foil or replaced by a metal rod of the same diameter.

Subclause 12.2.2 does not apply to starting aids which are purposely connected to the mains if they are not hazardous live parts.

NOTE See Annex A for a test for hazardous live parts.

12.2.3 Test – Electric strength

A voltage of substantially sine-wave form, with a frequency of 50 Hz or 60 Hz and the value specified in Table 16, shall be applied for 1 min across the insulation shown in that table.

Initially, no more than half the specified voltage shall be applied, it is then raised gradually to the full value.

In the case of a luminaire where it is not possible to remove coupling capacitors, leading to an incorrect result in an AC test, an alternative dielectric strength test with a DC test voltage may be applied according to the following test procedure:

- *The DC test voltage shall be substantially free of ripple. This requirement is fulfilled if the absolute peak values of the voltage do not deviate from the absolute average value by more than 3 %. The average value of the DC test voltage shall be equal to the peak value of the AC test voltage as required in Table 16.*
- *The DC test voltage shall be raised uniformly from 0 V to the value specified above within 5 s and held at that value for 1 min.*

For the high-voltage source used for the test, when the output terminals are short-circuited after the output voltage has been adjusted to the appropriate test voltage, the output current shall be at least 200 mA.

The overcurrent relay shall not trip when the output current is less than 100 mA.

The value of the test voltage applied shall be within ± 3 %.

The metal foil shall be so placed that no flashover occurs at the edges of the insulation.

For class II luminaires incorporating both reinforced insulation and double insulation, the voltage applied to the reinforced insulation shall not overstress the basic insulation or the supplementary insulation.

Glow discharges without a drop in voltage are ignored.

No flashover or breakdown shall occur during the test.

These requirements do not apply to starting aids which are purposely connected to the mains if they are not hazardous live parts.

For luminaires with ignitors, the electric strength of parts of the luminaire that are stressed by the pulse voltage is tested with the ignitor operating, to ensure that the luminaire insulation, wiring and similar parts are adequate.

For luminaires with ignitors and lampholders which, according to the lampholder manufacturer's instructions, achieve their maximum impulse voltage protection only with a lamp inserted, a dummy lamp shall be inserted for this test.

NOTE 1 The dummy lamp can be supplied with the type test sample.

NOTE 2 This requirement enables the cap/holder design to be kept to a reasonable size while allowing the pulse voltage to rise to a level which will ensure hot restarting of a discharge lamp (for example in studio applications).

The luminaire with ignitors is connected to a supply of 100 % rated voltage, for a period of 24 h. Ignitors that become defective during this period are replaced immediately. The electric strength test with the values specified in Table 16 is then applied to the luminaire with all the terminals (except any earthing terminal) of the ignitor connected together.

For luminaires with manual ignitors such as push-buttons, the luminaire is connected to a supply of 100 % rated voltage and subjected to a "3 s on/10 s off" switching cycle for a total period of 1 h. Only one ignitor is used for this test.

Luminaires with ignitors provided with ballasts which are marked for exclusive use with an ignitor having a time limitation device, conforming to IEC 61347-2-9, shall be subjected to the same test but for a period consisting of 250 on/off cycles, keeping an off-period of 2 min.

No flashover or breakdown shall occur during the electric strength test.

When carrying out the electric strength test on luminaires containing electronic controlgear, rated lamp circuit voltages greater than the luminaire supply voltage rating can be present. This is indicated by the rating U_{out} marked on the controlgear. In these instances, the test voltage applied to parts of the lamp circuit shall be calculated from the U_{out} rating marked on the controlgear instead of U where U is the working voltage.

Furthermore, dependent on the type of insulation between the mains supply and output circuits of the controlgear, the value of working voltage U used for the electric test shall be based on U_{out} , mains supply, or U_{out} plus mains supply, as detailed by Table T.1.

Table 16 – Electric strength

Insulation of parts	Test voltage V		
	Class I luminaires	Class II luminaires	Class III luminaires
SELV/PELV:			
Between current-carrying parts of different polarity	A	A	A
Between current-carrying parts and the mounting surface ^a	A	A	A
Between current-carrying parts and metal parts of the luminaire ^d	A	A	A
Between the outer surface of a flexible cord or cable where it is clamped in a cord anchorage and accessible metal parts	A	A	A

Insulation of parts	Test voltage V		
	Class I luminaires	Class II luminaires	Class III luminaires
Insulating bushings as described in Clause 8	A	A	A
Other than SELV/PELV:			
Between hazardous live parts of different polarity	B	B	-
Between hazardous live parts and the mounting surface ^a	B	B and C, or D ^e	-
Between hazardous live parts and metal parts of the luminaire	B	B and C, or D ^e	-
Between hazardous live parts which can become of different polarity through action of a switch	B ^c	B ^c	-
Between the outer surface of a flexible cord or cable where it is clamped in a cord anchorage and accessible metal parts	B	C	-
Insulating bushings as described in Clause 8	B	C	-
A Basic insulation for voltages of SELV/PELV	500		
B Basic insulation for voltages other than SELV/PELV	$2U^b + 1\ 000$		
C Supplementary insulation	$2U^b + 1\ 000$		
D Double or reinforced insulation	$4U^b + 2\ 000$		
<p>^a The mounting surface is covered with metal foil for the purpose of this test.</p> <p>^b U in this case is the nominal line-to-neutral voltage of the neutral-earthed supply system. Advice can be found in IEC 60664-1.</p> <p>^c During the test, the switch can influence the result. In the case of electronic disconnection according to IEC 61058-1:2016, 7.14.1 or micro disconnection according to IEC 61058-1:2016, 7.14.2, it can be necessary to remove the switch from the circuit.</p> <p>^d This requirement does not exclude the connection of the PELV circuits to earth for functional purposes.</p> <p>^e This table gives details for the situations where no electrical insulation is provided between the mains supply and output circuits of the controlgear. Where the controlgear provides basic or double or reinforced insulation from the mains supply, the required insulation from the hazardous live part to the accessible part, including the mounting surface, may be different. As a consequence of the requirements according to Table T.1, the test voltage may be modified.</p>			

12.3 Touch current, protective conductor current and electric burn

The touch current or protective conductor current that can occur during normal operation of the luminaire shall not exceed the values given in Table 17 when measured in accordance with Annex G.

Table 17 – Limits of touch current or protective conductor current and electric burn

Touch current, protective conductor current and electric burn		Max. limits
Touch current		
Type of luminaire	Supply currents	
Class II luminaires	all	0,7 mA (peak)
Class I luminaires rated up to and including 16 A fitted with a plug connectable to an unearthed socket-outlet ^a	all	0,7 mA (peak)
Metal parts of class I luminaires isolated by double or reinforced insulation	all	0,7 mA (peak)
Protective conductor current		
Type of luminaire	Supply currents	
Class I luminaires fitted with a single or multiphase plug, rated up to and including 32 A	≤ 4 A	2 mA (RMS)
	> 4 A but ≤ 10 A	0,5 mA/A (RMS)
	> 10 A	5 mA (RMS)
Class I luminaires intended for permanent connection	≤ 7 A	3,5 mA (RMS)
	> 7 A but ≤ 20 A	0,5 mA/A (RMS)
	> 20 A	10 mA (RMS) or according to manufacturer's instructions
Electric burn		
Type of luminaire	Supply currents	
All types of luminaires	all	u.c.
NOTE In Australia and New Zealand there is no allowance for protective conductor current greater than 10 mA.		
^a Testing is not required where the manufacturer's instructions supplied with the luminaire advise that the luminaire must be earthed.		

Compliance is checked in accordance with Annex G.

NOTE 1 For luminaires incorporating AC supplied electronic controlgear, the leakage current can be greatly dependent upon the spacing between the lamp and the earthed starting aid, due to the high frequency operation of the lamp.

NOTE 2 Further explanations regarding the measurement of touch current and protective conductor current can be found in IEC 60990.

13 Creepage distances and clearances

13.1 General

Clause 13 specifies minimum requirements for creepage distances and clearances in luminaires.

NOTE 1 The way in which creepage distances and clearances are measured is specified in IEC 60664-1.

NOTE 2 The calculation method and the structure of the creepage distances and clearances are taken from IEC 60664-1:2020 and IEC 60664-4.

NOTE 3 Annex Q provides information about values for overvoltage category III.

13.2 Requirements

13.2.1 General

Parts detailed in Table K.1 shall be adequately spaced. Creepage distances and clearances shall be not less than the values given in Table 18, Table 19 and Table 20. Creepage distances shall not be less than the required minimum clearance.

No values are specified for working voltages below and including 25 V AC and 60 V DC as the test voltage of Table 16 is considered sufficient.

Distances between current-carrying parts of opposite polarity shall comply with the requirements for basic insulation.

The minimum distances specified are based on the following parameters:

- for use up to 2 000 m above sea level;
- pollution degree 2 where normally only non-conductive pollution occurs, but occasionally a temporary conductivity caused by condensation is to be expected;
- equipment of overvoltage category II which is energy-consuming equipment to be supplied from the fixed installation.

For details of pollution degrees or overvoltage categories, IEC 60664-1 should be consulted.

Compliance is checked by measurements made with and without conductors of the largest section connected to the terminals of the luminaires. Internal wiring terminals of luminaires shall be checked with actual conductors supplied with the luminaire fitted.

The contribution to the creepage distance of any groove less than 1 mm wide is limited to its width.

A creepage or a clearance distance may be split into several parts. Any air gap less than 1 mm wide is ignored in calculating the total distances, unless the total clearance is less than 3 mm where one third of the air gap width shall be taken into account.

For luminaires provided with an appliance inlet, the measurements are made with an appropriate connector inserted.

Distances through slots or openings in external parts of insulating material are measured with metal foil in contact with the accessible surface. The foil is pushed into corners and similar places by means of the standard test finger (test probe B according to IEC 61032:1997, Figure 2), but it is not pressed into openings.

Reductions for creepage distances and clearances are allowed for luminaires which are (or have parts) protected against pollution by the use of coating or potting, if the requirements given in IEC 61347-1:2015, Annex P are fulfilled.

The values in Table 18 and Table 19 do not apply to components for which separate IEC publications exist, but do apply to mounting and accessibility distances to the component when it is incorporated in the luminaire.

Creepage distances at a supply terminal shall be measured from the live part in the terminal to any accessible metal parts, and the clearance shall be measured between incoming supply wiring and accessible metal parts, i.e. from a bare conductor of the largest cross-section to the metal parts which can be accessible. In case the length of insulation to be removed from the supply wiring by the installer is specified within the mounting instruction of the luminaire, this length of insulation shall be removed for the test. The minimum stripped conductor shall be in any case at least 8 mm even if a smaller distance is specified by the manufacturer. During the test the conductors shall be positioned centrally to the terminals as shown in Figure 43. At the internal wiring side of the terminal, the clearance shall be measured between live parts of the terminal and accessible metal parts (see Figure 43).

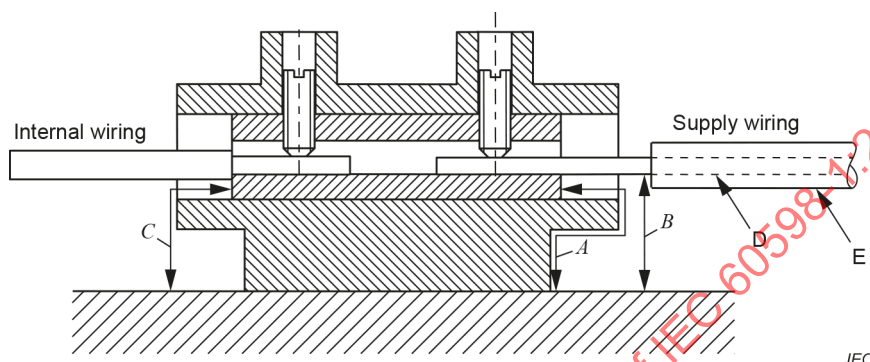

Key

- A creepage distance
- B clearance (supply wiring)
- C clearance (internal wiring)
- D conductor
- E insulation

Figure 43 – Illustration of creepage and clearance measurements at a supply terminal

NOTE The measurements of the clearances from supply and from internal wiring can differ because the luminaire manufacturer does not have control over the length of insulation removed from the supply wiring by the installer. Nevertheless it can be expected that the installer will follow the instructions from the luminaire manufacturer.

When creepage distances and clearances are determined at bushings, cord anchorages, wire carriers or clips, the measurement shall be made with the cable fitted.

13.2.2 Creepage distances

The minimum values for creepage distances are listed in Table 18.

For the dimensioning of the creepage distances the RMS values of the working voltage shall be taken into account. In the case of an insulated circuit the requirements of 7.31 and Annex T shall be taken into consideration to find the working voltage.

The values of Table 18 are valid for voltages with a frequency below 30 kHz. For higher frequencies the following requirements shall apply.

- If the combination of voltage and frequency requires higher creepage distances, the information provided by the controlgear manufacturer shall be followed, see footnote "b" of Table 18.
- If the luminaire is used in combination with or together with components or devices other than controlgear covered by the IEC 61347 series and which produces frequency above 30 kHz, the requirements of IEC 60664-4 shall apply.

**Table 18 – Minimum creepage distances for AC sinusoidal voltages up to 30 kHz
(to be used in conjunction with Annex K)**

Working voltage ^a V	Minimum creepage distance ^b mm			
	Basic or supplementary insulation		Reinforced insulation	
	PTI < 600	PTI ≥ 600	PTI < 600	PTI ≥ 600
25	0,5	0,5	– ^c	– ^c
50	1,2	0,6	– ^c	– ^c
150	1,6	0,8	3,2	1,6
250	2,5	1,25	5,0	2,5
500	5,0	2,5	10	5,0
750	7,5	3,75	16	7,5
1 000	10	5,0	20	10
1 500	15	7,5	30	15

Linear interpolation between lines is allowed.

NOTE 1 Proof tracking index (PTI) in accordance with IEC 60112.

NOTE 2 Values are based on IEC 60664-1:2020, Table F.5 (pollution degree 2, material groups I and III).

^a For creepage distances the equivalent DC voltage is equal to the RMS value of the sinusoidal AC voltage.

^b In the case of a combination of voltage and frequency which requires higher creepage than the values required in this table, the controlgear is marked with the details of this combination (maximum working peak output voltage \hat{U}_{out} and frequency f_{Uout}) – see IEC 61347-1:2015, 7.1, item w). For details and the required values for creepage, see IEC 61347-1:2015, 16.2.3.

^c Values under consideration.

In the case of creepage distances to parts not energized and not intended to be earthed, where tracking cannot occur, the values specified for material with a PTI ≥ 600 shall apply for all materials (independent of the real PTI).

For creepage distances subjected to working voltages of less than 60 s duration, the values specified for materials with a PTI ≥ 600 shall apply for all materials.

For creepage distances not liable to contamination by dust or moisture which can be achieved by coating or potting, the values specified for material with a PTI ≥ 600 shall apply (independent of the real PTI).

13.2.3 Clearances

The minimum values for clearances are listed in Table 19 and Table 20. Table 19 shall be applied to all circuits taking into consideration the transient coming from the mains supply. Table 20 is applicable to circuits where peak voltages are generated by the equipment (internally or externally).

The values of Table 19 and Table 20 are valid for voltages having a frequency below 30 kHz. For higher frequencies the following requirements shall apply:

- If the combination of voltage and frequency requires higher clearance than the value in Table 19 and Table 20, the equivalent transformed peak voltage (U_p) provided by the controlgear manufacturer shall be used. The value of U_p is directly comparable to the values given in Table 20. The value of U_p may be different for the evaluation of basic, supplementary and reinforced insulation.
- If the luminaire is used in combination with or together with components or devices other than controlgear covered by the IEC 61347 series and which produces frequency above 30 kHz, the requirements of IEC 60664-4 shall apply.

**Table 19 – Minimum clearances for working voltages
(to be used in conjunction with Annex K)**

Distances mm	RMS working voltage not exceeding V				
	50	150	300	600	1 000
Clearances with mains supply transients according to overvoltage category II ^b					
– Basic or supplementary insulation	0,2	0,5	1,5	3	5,5
– Reinforced insulation	0,2	1,5	3	5,5	8
Clearances without mains supply transients ^{a b}					
– Basic or supplementary insulation	0,2	0,2	0,2	0,2	0,7
– Reinforced insulation	0,2	0,2	0,2	0,6	1,6
^a The values in this row are applicable to circuits where it is ensured that they are free from transient (e.g. battery circuits).					
^b For clearances, the equivalent DC voltage is equal to the peak of the AC voltage. Interpolation between columns is not allowed, if transient according to the overvoltage category II have to be considered for the main supply.					

Minimum clearance distances for ignition pulse voltages and equivalent transformed peak voltage (U_p) are given in Table 20.

**Table 20 – Minimum distances for ignition pulse voltages
or equivalent transformed peak voltage U_p**

	Rated ignition pulse voltage or equivalent transformed peak voltage U_p								
	kV								
	2,0	2,5	3,0	4,0	5,0	6,0	8,0	10	12
Minimum clearance in mm ^a (basic and supplementary insulation)	1	1,5	2	3	4	5,5	8	11	14
Minimum clearance in mm ^a (reinforced insulation)	2,2	3,0	3,8	6,0	8,0	10,4	15	19,4	24
	Rated ignition pulse voltage or equivalent transformed peak voltage U_p								
	kV								
	15	20	25	30	40	50	60	80	100
Minimum clearance in mm ^a	18	25	33	40	60	75	90	130	170
Minimum clearance in mm ^a (reinforced insulation)	31,4	44	60	72	98	130	162	No values available	
NOTE The distances in Table 20 are derived from IEC 60664-1:2020, Table F.2, case A, inhomogeneous field conditions.									
^a Linear interpolation between columns is allowed.									

For distances subjected to both sinusoidal voltage as well as non-sinusoidal pulses, the minimum required distance shall be not less than the highest value indicated in Table 18, Table 19 and Table 20.

14 Endurance test and thermal test

14.1 General

Clause 14 specifies requirements relating to the endurance test and thermal tests of luminaires.

14.2 Selection of lamps and controlgear

Lamps used for the tests of Clause 14 shall be selected in accordance with Annex B.

The lamps used in the endurance test are operated above their rated power for extended periods, and shall not be used for the thermal tests. However, it is usually convenient to retain in the thermal test for abnormal operation those lamps that have been used in the thermal test for normal operation.

If the luminaire requires separate controlgear and this is not supplied with the luminaire, controlgear shall be selected for test purposes which is typical of normal production, and which complies with the relevant controlgear specification. In case of ballasts for discharge lamps the power delivered to a reference lamp by the ballast under reference conditions shall be within $\pm 3\%$ of rated lamp power. In case of constant voltage or constant current power supply, a laboratory power supply or a specially prepared controlgear that delivers the specified current or voltage, can be used.

NOTE 1 For reference conditions, see the relevant IEC controlgear standard.

NOTE 2 In the relevant lamp performance standards, the rated power can still be indicated as "objective" wattage. This wording will be corrected in future editions of these standards.

14.3 Endurance test

14.3.1 General

Under conditions representing cyclic heating and cooling in service, the luminaire shall not become unsafe.

Compliance is checked by carrying out the test described in 14.3.2.

14.3.2 Test

- a) *The luminaire shall be mounted in a thermal enclosure with means for controlling the ambient temperature within the enclosure.*

The luminaire shall be positioned on a similar mounting surface (and in the same operating position) as for the normal operation thermal test (see 14.4).

- b) *The ambient temperature within the enclosure shall be maintained within ± 2 °C of $(t_a + 10)$ °C during the test; t_a is 25 °C unless otherwise marked on the luminaire.*

The ambient temperature within the enclosure shall be measured in accordance with Annex I. Controlgear for operation separate from the luminaire shall be mounted in free air, not necessarily in the thermal enclosure, and shall be operated in an ambient temperature of 25 °C \pm 5 °C.

- c) *The luminaire shall be tested in the enclosure for a total duration of 168 h consisting of seven successive cycles of 24 h. Supply voltage as specified in item d) below shall be applied to the luminaire for the first 21 h and disconnected for the remaining 3 h of each cycle. The initial heating period of the luminaire is part of the first test cycle.*

The circuit condition shall be as in normal operation for the first six cycles, and as in abnormal operation (see Annex C) for the seventh cycle. For luminaires containing an electrical motor (e.g. a fan) the abnormal condition which most adversely affects the result of the test shall be selected.

For luminaires powered via information technology communication cable, the seventh cycle is carried out with the overvoltage condition as indicated in item d) considering the overvoltage as an abnormal condition.

For luminaires for which there is no abnormal condition test according to 14.5, the total test duration shall be 240 h (i.e. 10 \times 24 cycles at normal operation). For filament luminaires, the total test duration of 240 h shall apply in all cases.

- d) *During operating periods, the supply voltage for filament lamp luminaires, other than ELV, shall be $1,05 \pm 0,015$ times the voltage at which the rated power of the lamp is obtained.*

During operating periods, the supply voltage for other luminaires shall be $1,10 \pm 0,015$ times the rated voltage or the maximum of the rated voltage range.

For luminaires for constant voltage or constant current operation not equipped with controlgear the test shall be performed with 1,1 times the rated input constant voltage or rated input constant current as appropriate.

During operating periods, the supply voltage for class III luminaires, powered via information technology communication cable, shall be:

for cycles 1 to 6 (representing normal operation)

- 110 % of the rated input voltage of the luminaire at the relevant input port;*

for cycle 7 (representing abnormal operation)

- 130 % of the rated input voltage of the luminaire at the relevant input port for circuits greater than 5 V DC, with a minimum of 7,5 V DC and*
- 150 % of the rated input voltage of the luminaire at the relevant input port for circuits less than or equal to 5 V DC.*

- e) *If the luminaire ceases to operate because of a failure, the following shall apply.*
- *In the case of chance failure of a part of the luminaire (including the lamp), the instructions of 14.4.2, item g) shall apply.*
 - *If a thermal protective device operates during the first six cycles, the test shall be modified as follows.*
 - 1) *For luminaires with cyclic protective devices, the luminaire shall be allowed to cool until the device resets. For luminaires with one-shot thermal protective devices (thermal links), the device shall be replaced.*
 - 2) *For all kinds of luminaires, the test shall then be continued up to 240 h in total with the circuit and the temperature adjusted in such a way that the protective device just fails to operate. The luminaire is deemed to have failed the test if adjustment below the luminaire's rated characteristics is necessary to prevent the protective device operating.*
 - *If a thermal protective device operates during the seventh (abnormal conditions) cycle, it shall either be allowed to cool, or, in the case of a one-shot device, it shall be replaced, and the test continued with the circuit and temperature adjusted in such a way that the protective device just fails to operate.*
- f) *In the case of luminaires incorporating a constant light output function, the luminaire shall be operated with the output of the controlgear set to deliver the maximum output to the light source for which the luminaire has been designed.*

NOTE It is possible that the manufacturer will need to provide a specially prepared test sample.

It is considered that if a cut-out device operates during the seventh (abnormal condition) cycle, then the functioning of the intended protection has been proven.

Arrangements should be made to signal a break in operation. The effective test duration shall not be reduced as a consequence of such a break.

14.3.3 Compliance

After the test of 14.3.2, the luminaire and, for track-mounted luminaires, also the track and component parts of the track system, shall be visually inspected. No part of the luminaire shall have become unserviceable (other than as a chance failure as described in 14.3.2, item e)) and plastic Edison screw lampholders shall not be deformed. The luminaire shall not have become unsafe and shall not have caused damage to the track system. The marking of the luminaire shall be legible.

NOTE Symptoms of possible unsafe conditions include cracks, scorches and deformation.

14.4 Thermal test (normal operation)

14.4.1 General

Under conditions representing normal service, no part of the luminaire (including the light source), the supply wiring within the luminaire, or the mounting surface shall attain a temperature which would impair safety.

In addition, parts intended to be touched, handled, adjusted or gripped by hand while the luminaire is at operating temperature shall not be too hot for the purpose.

Luminaires shall not cause excessive heating of lighted objects.

Track-mounted luminaires shall not cause excessive heating of tracks on which they are mounted.

Compliance is checked by carrying out the test described in 14.4.2. The test conditions for measuring the track temperature shall be as given in IEC 60570:2003, 12.1.

For luminaires containing an electrical motor, this motor shall operate as intended during the test.

14.4.2 Test

The temperature shall be measured as indicated in 14.4.3 in accordance with the following conditions.

- a) The luminaire shall be tested in a draught-proof enclosure designed to avoid excessive changes in ambient temperature. A luminaire suitable for surface mounting shall be mounted on a surface as described in Annex D. An example of a draught-proof enclosure is given in Annex D, but other types of enclosure may be used if the results obtained are compatible with those that would be obtained by the use of the enclosure described in Annex D. (For controlgear separate from the luminaire, see 14.4.2, item h)).

The luminaire shall be connected to the power supply with the wiring and any materials (e.g. insulating sleeves) supplied with the luminaire for the purpose.

Connection shall be in accordance with the instructions provided with the luminaire or marked on it. Wiring required to connect the luminaire under test to the supply and not supplied with it should be of a type representative of common practice. Such wiring not supplied with the luminaire is hereafter referred to as the test piece.

Temperature measurements shall be made in accordance with Annex E and Annex I.

- b) The operating position shall be the thermally most onerous operating position which may reasonably be adopted in service. For fixed non-adjustable luminaires, a position shall not be selected if it is stated to be not permissible in instructions supplied with, or marked on, the luminaire. For settable and adjustable luminaires, the required distance from lighted objects shall be respected if marked on the luminaire, except for luminaires without provision for mechanical locking in any position, when the front rim of the reflector if any, otherwise the lamp, shall be positioned 100 mm from the mounting surface.
- c) The ambient temperature within the draught-proof enclosure shall be within the range of 10 °C to 30 °C and should preferably be 25 °C. It shall not vary by more than ± 1 °C during measurements and during a preceding period long enough to affect the results.

If, however, a lamp has temperature-sensitive electrical characteristics (e.g. a fluorescent lamp), or if the t_a rating of the luminaire exceeds 30 °C, the ambient temperature within the draught-proof enclosure shall be within 5 °C of the t_a rating and should preferably be the same as the t_a rating.

An alternative test method is given in Clause D.3. In case of doubt the test method of 14.4.2, item c) shall be taken as a reference test method.

- d) The test voltage for the luminaire shall be as follows.
- Filament lamp luminaires other than ELV: that voltage which produces 1,05 times the rated power of the test lamp (see Annex B) except that heat test source (HTS) lamps are always operated at the voltage marked on the lamp.
 - For other luminaires: 1,06 times the rated voltage or the maximum of the rated voltage range.
 - For motors contained in luminaires: 1,06 times the rated voltage (or the maximum of the rated voltage range of the luminaire).

Exception

For determination of the average temperature of the winding of a component with t_w marking and for the determination of the case temperature of a component with t_c marking, except capacitors, the test voltage shall be 1,00 times the rated voltage. This exception applies only to the measurement of the winding or case temperature and does not apply, for example, to the measurement of a terminal block on the same component.

Capacitors whether carrying t_c or not are tested at 1,06 times the rated voltage when operated within fluorescent and other discharge luminaires.

NOTE 1 If a luminaire contains both a filament lamp and a tubular fluorescent or other discharge lamp or a motor, it can be necessary to provide it temporarily with two separate supplies.

For luminaires for constant voltage or constant current operation not equipped with controlgear, the test shall be performed with 1,1 times the rated input constant voltage or rated input constant current as appropriate.

During operating periods, the supply voltage for class III luminaires, powered via information technology communication cable, shall be:

– 106 % of the rated input voltage of the luminaire at the relevant input port.

- e) *During and immediately before a measurement, the supply voltage shall be held within ± 1 % and preferably within $\pm 0,5$ % of the test voltage. The supply voltage shall be held within ± 1 % of the test voltage during such preceding period as may affect the measurement; this period shall be not less than 10 min.*
- f) *Measurements shall not be taken until the luminaire has stabilized thermally, i.e. temperatures are changing at a rate less than 1 °C per hour.*
- g) *If the luminaire ceases to operate because of a defective part of the luminaire (including the lamp), the part should be replaced and the test continued. The luminaire shall be stabilized before further measurements are taken. If, however, a hazardous condition has arisen, or if any part becomes unserviceable as a type defect, then the luminaire is deemed to have failed the test. If a protective device in the luminaire operates, the luminaire is deemed to have failed.*
- h) *If remote controlgear or components are supplied as part of a luminaire, they shall be mounted and operated in accordance with the manufacturer's instructions. Temperatures of all parts shall comply with the limits specified by Clause 14.*

If remote controlgear is not supplied as part of the luminaire, the manufacturer will provide controlgear typical of normal use. The controlgear shall be operated in free air and in an ambient temperature of 25 °C \pm 5 °C, and shall provide the output parameter as mentioned under d). The temperature of the controlgear shall not be measured.

- i) *In case of doubt in the test for filament lamp luminaires, the test shall be repeated with heat test source (HTS) lamps, if available. For temperatures which are mainly governed by the cap temperature of the lamp, the values obtained by HTS lamps are decisive. For those temperatures which are mainly governed by radiation, the values obtained by normal production lamps with clear bulbs are decisive.*
- j) *The light beam from the luminaire, for luminaires covered by 6.3.13, is directed towards a matt black painted wooden surface mounted perpendicular to the main direction of the light and similar to that described in Annex D. In case more than one lamp is in use, the centre lamp shall be directed as specified above. All other lamps shall be directed in order to achieve a common focus. Luminaires are mounted at the distance from the surface which is marked on the luminaire.*

During the tests, measurements shall be made of the temperature of certain insulating parts, as required for the tests of Clause 15.

- k) *For the measurement of lampholder temperatures for double-capped fluorescent lamps, the hot junction of the thermocouple shall be located flush with that surface of the holder adjacent to the lamp cap. If this is not possible, it should be placed as close as possible to this point but without touching the lamp cap.*

NOTE 2 The luminaire manufacturer can provide the type test sample with a thermocouple already attached to the lampholder. Usually, only one lampholder is prepared in such a way.

- l) *During the test for compliance, the through wiring and the looping-in wiring shall be loaded to the maximum value allowed by the size of the wire, or at a value specified by the manufacturer in the installation instructions. The socket-outlet, if any, is loaded with the declared value specified by the manufacturer and, if not declared, with its rated current at rated voltage.*

NOTE 3 In the following countries, during thermal testing, both the through wiring and the looping-in wiring are required to be loaded to the maximum value allowed by the size of the wire: Canada, USA.

- m) *In the case of luminaires incorporating a constant light output function the luminaire shall be operated with the output of the controlgear set to deliver the maximum output to the light source for which the luminaire has been designed.*

NOTE 4 It is possible that the manufacturer will need to provide a specially prepared test sample.

14.4.3 Compliance

In the test of 14.4.2, none of the temperatures shall exceed the appropriate values given in Table 21 and Table 22 (subject only to the concession of item a) of this subclause) when the luminaire is operated at its rated ambient temperature t_a .

In those cases where the temperature in the test enclosure differs from t_a , this difference shall be taken into account when applying the limits in Table 21 and Table 22 (see also 14.4.2, item c)).

- a) *The temperature shall not exceed the values specified in Table 21 and Table 22 by more than 5 °C.*

NOTE The allowance of 5 °C is made to take into account the inevitable variability of temperature measurements in luminaires.

- b) *The temperature of any part of the luminaire liable to thermal degradation in service shall not exceed a value which corresponds to a reasonable service period for the particular type of luminaire. Generally agreed values for principal parts of luminaires are given in Table 21 and values for common materials, when used in luminaires, are listed in Table 22. These values are specified here to obtain uniform assessment; slightly different values may be quoted elsewhere on the basis of other forms of materials testing or for other applications.*

If materials are used which are claimed to withstand higher temperatures than those specified in Table 22, or if other materials are used, they shall not be exposed to temperatures in excess of those which have been proved permissible for these materials.

- c) *The temperature of the test piece (see 14.4.2, item a)), if PVC-insulated, shall not exceed 90 °C (or 75 °C where it is stressed, for example clamped), or such higher temperatures as may be indicated on the luminaire or in the manufacturer's instructions supplied with the luminaire in accordance with the requirements of Clause 6. The limit shall be 120 °C for any PVC-insulated wire (internal or external wiring) even when additionally protected by a heat-resisting sleeve supplied with the luminaire. The sleeve shall comply with the requirements of 7.9.2.*

Table 21 – Maximum temperatures under the test conditions of 14.4.3, for principal parts

Part	Maximum temperature °C
Lamp caps	As specified in the appropriate IEC lamp standard^a
Windings in ballasts or transformers with t_w marking	t_w
Case (of capacitor, starting device, electronic controlgear or convertor, LED module, etc.)	
If t_c is marked	t_c^b
For capacitor if t_c is not marked	50
Windings in transformers, motors, etc., if the winding insulation system according to IEC 60085 is:	
– of class A material ^c	100
– of class E material ^c	115
– of class B material ^c	120
– of class F material ^c	140
– of class H material ^c	165
Insulation of wiring:	See Table 22 and 14.4.3, items b) and c)
Contacts of ceramic lampholders and insulating material of lampholders and starterholders:	
T1 or T2 marked (B15 and B22) ^d (IEC 61184)	165 for T1 and 210 for T2
Other types with T marking (IEC 60238, IEC 60400, IEC 60838 series ^e and IEC 61184)	T marking
Other types without T marking (E14, B15) (IEC 60238 and IEC 61184)	135
(E27, B22) (IEC 60238 and IEC 61184) (E26)	165
(E40) (IEC 60238) (E 39)	225
Fluorescent lampholders, starterholders and miscellaneous lampholders without T marking (IEC 60400 and IEC 60838 series ^e)	80
Switches marked with individual ratings:	
With T marking	T marking
Without T marking	55
Switches that comply with IEC 60669-1 or IEC 60669-2-1	35 ^h
Other parts of the luminaire (according to material and use):	See Table 22 and 14.4.3, item b)
Mounting surface:	
Normally flammable surface	90
Non-combustible surface	Not measured
Means of adjustment and its surrounding space ^f	
Metal parts	60
Non-metal parts	75
Objects lighted by spotlights (see 14.4.2))):	90 (of test surface)
Track (for track-mounted luminaires)	As stated by the track manufacturer ^g

Part	Maximum temperature °C
Lamp caps	As specified in the appropriate IEC lamp standard^a
Plug-in independent controlgear:	
– case parts intended to be gripped by hand	75
– plug/socket interface	70
– all other parts	85
Replaceable glow-starting devices	80 ⁱ
Surface of recessed luminaires above suspended ceiling, covered with thermal insulating material	90
<p>^a For luminaires marked with information concerning the use of special lamps, or if it is obvious that special lamps are to be used, a higher value, as specified by the lamp manufacturer, is allowed. IEC 60357 and IEC 60682 provide information for the measurement of pinch temperature for tungsten-halogen lamps. These measurements are required for performance criteria of lamps and not safety criteria of the luminaire. (Single-capped fluorescent lamps are excluded from being measured under normal operation test conditions, see Table 23).</p> <p>This does not apply to lamps covered by the scope of IEC 60432-2. The relevant information in this document for luminaire design shall be observed.</p> <p>^b Measured at the given reference point marked by the device manufacturer.</p> <p>^c The material classification is in accordance with IEC 60085 and the IEC 60216 series.</p> <p>^d Temperature measured on the rim of a corresponding cap.</p> <p>^e For bi-pin lampholders, in case of doubt, the average of the contact temperature measurements should be used.</p> <p>^f For adjustable luminaires where the mounting instructions provide clear guidance to mount out of reach, and for settable luminaires, the temperature limits for the means of adjustment are not applicable.</p> <p>^g For measuring conditions for the track temperature, see IEC 60570:2003, 12.1.</p> <p>^h This temperature limit is the ambient temperature measured as close as possible to the switch.</p> <p>ⁱ This temperature limit is for performance and is not a safety recommendation.</p>	

Table 22 – Maximum temperatures under the test conditions of 14.4.3, for common materials used in luminaires

Part	Maximum temperature °C
Insulation of wiring (internal and external), supplied with luminaire ^b :	
Glassfibre silicone-varnish impregnated	200 ^a
Polytetrafluoroethylene (PTFE)	250
Silicone rubber (not stressed)	200
Silicone rubber (compressive stress only)	170
Rubber or ordinary polyvinyl chloride (PVC)	90 ^a
Heat-resisting polyvinyl chloride (PVC)	105 ^a
Ethylene vinyl acetate (EVA)	140 ^a
Insulation of fixed wiring (as a fixed part of the installation not supplied with the luminaire) ^a :	
Unsleeved	90 ^c
Appropriate sleeving supplied with the luminaire	120

Part	Maximum temperature °C
Thermoplastics:	
Acrylonitrile-butadiene-styrene (ABS)	95
Cellulose acetate butyrate (CAB)	95
Polymethyl methacrylate (acrylic)	90
Polystyrene	75
Polypropylene	100
Polycarbonate	130
Polyvinyl chloride (PVC) (where not used for electrical insulation)	100
Polyamide (nylon)	120
Thermosetting plastics:	
Mineral-filled phenol-formaldehyde (PF)	165
Cellulose-filled phenol-formaldehyde (PF)	140
Urea-formaldehyde (UF)	90
Melamine	100
Glassfibre-reinforced polyester (GRP)	130
Other materials:	
Resin-bonded paper or fabric	125
Silicone rubber (where not used for electrical insulation)	230
Rubber (where not used for electrical insulation)	90
Wood, paper, textiles and the like	90
Permanent magnet used for luminaire or part of luminaire suspension	Maximum continuous working temperature declared by the magnet manufacturer
<p>^a Reduced by 15 °C where insulation is stressed, e.g. clamped or flexed.</p> <p>^b Cable specifications usually quote different maximum temperatures but these are based on continuous operating temperatures rather than the test conditions given in this document.</p> <p>^c This temperature is the maximum permitted under the artificial test conditions given in this table, for example draught-proof enclosure and test supply voltage above the rated value for the luminaire. It is important to note that, in some countries, the European installation standards and the European cable standards specify a temperature of 70 °C to be the maximum that PVC fixed wiring can sustain in normal continuous operation.</p>	

14.5 Thermal test (abnormal operation)

14.5.1 General

Under conditions representing abnormal service conditions (where applicable, but not representing a defect in the luminaire or misuse), parts of the luminaire and the mounting surface shall not attain excessive temperatures and the wiring within the luminaire shall not become unsafe.

NOTE Symptoms of possible unsafe conditions include cracks, scorches and deformation.

Track-mounted luminaires shall not cause excessive heating of tracks on which they are mounted.

Compliance is checked by carrying out the test described in 14.5.2.

14.5.2 Test

Temperatures of parts listed in Table 23 shall be measured in accordance with the following conditions.

- a) The test shall be carried out if, during service, the luminaire can be in an abnormal condition as in cases 1), 2), 3), 4) or 5) below, and if this condition would cause any part to be at a higher temperature than during normal operation (in which case a preliminary trial can be necessary).

If more than one abnormal condition is possible, that condition which most adversely affects the results of the tests shall be selected.

The test is not applicable to fixed non-adjustable filament lamp luminaires, except in case 3) below.

- 1) A possibly unsafe operating position, arising other than from misuse, for example if by accident an adjustable luminaire is bent in the direction of the mounting surface by using a force of 30 N minimum during a short period of time and on the most unfavourable point on the luminaire.
- 2) A possibly unsafe circuit condition arising other than from defective manufacture or misuse; for example a circuit condition occurring at the end of the service period of a lamp or of a starter (see Annex C).
- 3) A possibly unsafe operation condition arising from the use of a GLS lamp in a filament lamp luminaire intended for a special lamp, for example, if temporarily, a special lamp is replaced by a GLS lamp of the same wattage.
- 4) A possible unsafe circuit condition arising from a short-circuit in the output circuit (including the transformer and the electronic step-down convertor itself) of a luminaire with transformer or electronic step-down convertor fitted for lamp voltage supply.
- 5) A possible unsafe condition arising from overvoltage for a luminaire powered via information technology communication cable.

Test 2) is applicable only to tubular fluorescent and other discharge lamp luminaires.

Test 4) shall be made with a short-circuit in the lampholder. During test 4), the temperature rise due to heat emanating from the lamp to the mounting surface shall be checked by the test according to item 1), while the temperature rise due to heat emanating from the transformer or electronic step-down convertor shall be measured with the contacts of the lampholder being short-circuited.

Luminaires containing an electrical motor are operated with the rotor locked against rotation.

In the case of the presence of one or more motors, the test should be made in accordance with the most critical condition (see Annex C).

The luminaire shall be tested under the conditions specified in 14.4.2, items a), c), e), f), h) and l). In addition, the following shall apply.

- b) The test voltage shall be as follows.

Filament lamp luminaires: as specified in 14.4.2, item d).

Tubular fluorescent and other discharge lamp luminaires: 1,1 times the rated voltage or the maximum of the rated voltage range.

For motors contained in luminaires: 1,1 times the rated voltage (or the maximum of the rated voltage range of the luminaire).

Luminaires containing transformer or convertors during short-circuit according to test 4): between 0,9 and 1,1 times the rated supply voltage, whichever is the most unfavourable.

During operating periods, the supply voltage for class III luminaires, powered via information technology communication cable, shall be:

- 130 % of the rated input voltage of the luminaire at the relevant input port for circuits greater than 5 V DC, with a minimum of 7,5 V DC and
- 150 % of the rated input voltage of the luminaire at the relevant input port for circuits less than or equal to 5 V DC.

NOTE 1 If a luminaire contains both a filament lamp and a tubular fluorescent or other discharge lamp, or a motor, it can be necessary to provide it temporarily with two separate supplies.

For luminaires for constant voltage or constant current operation not equipped with controlgear the test shall be performed with 1,1 times the rated input constant voltage or rated input constant current as appropriate.

- c) *If the luminaire ceases to operate because of a defective part of the luminaire (including the lamp), the part should be replaced and the test continued. The luminaire shall be stabilized before further measurements are taken. If, however, a hazardous condition has arisen, or if any part becomes unserviceable as a type defect, then the luminaire is deemed to have failed the test.*

If a protective device in the luminaire (e.g. a thermal or current cut-out of the one-shot or cycling type) operates during the test, the highest temperatures reached should be taken as the final temperatures.

- d) *If the luminaire incorporates a capacitor (other than a capacitor connected directly across the supply), this capacitor shall be short-circuited, notwithstanding the requirements of Annex C, if the voltage across it under test conditions would exceed 1,25 times its rated voltage for self-healing capacitors or 1,3 times its rated voltage for non-self-healing capacitors.*

Luminaires for some metal halide lamps and some high-pressure sodium vapour lamps which, according to the lamp specification can lead to ballast, transformer or starting device or transformer overheating are tested in accordance with Annex C, item b) 2).

- e) *In the case of luminaires incorporating a constant light output function, the luminaire shall be operated with the output of the controlgear set to deliver the maximum output to the light source for which the luminaire has been designed.*

NOTE 2 It is possible that the manufacturer will need to provide a specially prepared test sample.

14.5.3 Compliance

In the test of 14.5.2, none of the temperatures shall exceed the appropriate value given in Table 23, Table 24 and Table 25 by more than 5 °C when the luminaire is operated at its rated ambient temperature t_a . In cases where the temperature of the test enclosure differs from t_a , the difference shall be taken into account when applying the limits given in the relevant table.

Table 23 – Maximum temperatures under the test conditions of 14.5.2

Part	Maximum temperature °C
Caps of single-capped fluorescent lamps	As specified in the appropriate IEC lamp standard^c
Windings in ballasts or transformers with tw marking ^a	See Table 24 and Table 25
Windings in transformers, motors etc., if the winding insulation system according to IEC 60085 is:	
– of class A material ^b	150
– of class E material ^b	165
– of class B material ^b	175
– of class F material ^b	190
– of class H material ^b	210
Capacitor case:	
– if t_c is not marked	60
– if t_c is marked.	$t_c + 10$
Ignitor case	$(t_c + X)$ as marked on the ignitor

Part	Maximum temperature °C
Caps of single-capped fluorescent lamps	As specified in the appropriate IEC lamp standard^c
Mounting surface:	
– surface illuminated by the lamp (settable and adjustable luminaires according to 14.5.2 a) 1)	175
– surface heated by the lamp (portable luminaires according to IEC 60598-2-4:2017, 4.13)	175
– normally flammable surface	130
– non-combustible surface (luminaires with symbol or warning notice)	Not measured
Track (for track-mounted luminaires)	As stated by the track manufacturer
Mains socket-outlet-mounted luminaires and plug-controlgear or transformer case parts intended to be gripped by hand	75
Surface of recessed luminaires above suspended ceiling, covered with thermal insulating material	130
<p>^a The maximum temperatures specified in column S4.5 of Table 24 or Table 25 apply unless otherwise marked on the ballast.</p> <p>^b The material classification is in accordance with IEC 60085 and the IEC 60216 series.</p> <p>^c Information regarding point(s) of measurement and temperature limits is given in IEC 61199:2011, Annex C IEC 61199:2011/AMD1:2012, Annex C and IEC 61199:2011/AMD2:2014, Annex C.</p>	

Table 24 – Maximum temperature of windings under abnormal operating conditions and at 110 % of rated voltage for controlgear

		Maximum temperature					
		°C					
Constant S		S4.5	S5	S6	S8	S11	S16
For $t_w =$	90	171	161	147	131	119	110
	95	178	168	154	138	125	115
	100	186	176	161	144	131	121
	105	194	183	168	150	137	126
	110	201	190	175	156	143	132
	115	209	198	181	163	149	137
	120	217	205	188	169	154	143
	125	224	212	195	175	160	149
	130	232	220	202	182	166	154
	135	240	227	209	188	172	160
	140	248	235	216	195	178	166
	145	256	242	223	201	184	171
	150	264	250	230	207	190	177

Table 25 – Maximum temperature of windings under abnormal operating conditions and at 110 % of rated voltage for controlgear marked "D6"

		Maximum temperature					
		°C					
Constant S		S4.5	S5	S6	S8	S11	S16
For $t_w =$	90	158	150	139	125	115	107
	95	165	157	145	131	121	112
	100	172	164	152	137	127	118
	105	179	171	158	144	132	123
	110	187	178	165	150	138	129
	115	194	185	171	156	144	134
	120	201	192	178	162	150	140
	125	208	199	184	168	155	145
	130	216	206	191	174	161	151
	135	223	213	198	180	167	156
	140	231	220	204	186	173	162
	145	238	227	211	193	179	168
	150	246	234	218	199	184	173

For controlgear subjected to an endurance test duration other than 30 days or 60 days, Equation (2) as specified in IEC 61347-1:2015, Clause 13 should be used to calculate the maximum temperature which should correspond to the number of days equal to two-thirds of the theoretical endurance test.

(An explanation of the constant S and its use is given in the relevant IEC auxiliary standard.)

14.6 Thermal test (failed windings in controlgear)

14.6.1 General

These tests apply only to luminaires classified for mounting on normally flammable surfaces and incorporating controlgear that either does not meet the spacing requirements of 7.16.2 or does not provide thermal protection in accordance with 7.16.3. Electronic controlgear and small wound devices that may be incorporated into these components are exempt from the requirements of 14.6.

14.6.2 Test for luminaires without thermal cut-outs

The luminaire shall be tested under the conditions specified in 14.4.2, items a), c), e), f), h) and l). In addition, the following also applies.

20 % of the lamp circuits in the luminaire, and not less than one lamp circuit, shall be subjected to abnormal conditions (see 14.5.2, item a)).

The circuits which have the most thermal influence on the mounting surface shall be chosen, and other lamp circuits shall be operated at rated voltage, or at the maximum of the rated voltage range under normal conditions.

The circuits subjected to the above conditions shall then be operated at 0,9, 1,0 and 1,1 times the rated voltage (or the maximum of the rated voltage range). When conditions are stable at each of these three test voltages, the highest winding temperature and the highest temperature of any part of the mounting surface shall be measured.

For fluorescent lamp luminaires with an AC supplied electronic controlgear incorporating a filter coil, the voltage required to give nominal operating current shall be determined. The filter coil shall be operated at 0,9, 1,0 and 1,1 times this voltage. When conditions are stable at each of these three test voltages, the highest winding temperature and the highest temperature of any part of the mounting surface shall be measured. All other parts of the controlgear and lamp shall be inoperative for this test.

Compliance is checked as follows.

- a) The temperature of the mounting surface shall not exceed 130 °C when the lamp circuit(s), subjected to abnormal conditions, is (are) operated at 1,1 times the rated voltage.
- b) The values of temperature measured at 0,9, 1,0 and 1,1 times the rated voltage (or the maximum of the voltage range) are used for the linear regression formula in calculating the temperature of the mounting surface in relation to a ballast or transformer winding temperature of 350 °C. If the difference between winding temperature measurements at 0,9 and 1,1 co-ordinates is less than 30 K, a fourth point is added, whose co-ordinates are winding t_a , mounting surface t_a . The best straight line is drawn through the points on the graph. The estimated temperature of the mounting surface corresponding to a ballast winding temperature of 350 °C shall not exceed 180 °C.

NOTE t_a is the rated t_a of the luminaire.

- c) For track-mounted luminaires, no part of the track shall show symptoms of unsafe deterioration, for example cracks, scorches or deformation.

14.6.3 Test for luminaires with temperature sensing controls

This test is required for luminaires with temperature sensing controls external to the controlgear or transformer and for luminaires with temperature declared thermally protected controlgear provided with symbol  with a marked value above 130 °C.

The luminaire shall be set up for this test as described in 14.6.2.

The circuits subjected to the above conditions shall be operated with a slowly and steadily increasing current through the windings until the thermal cut-out operates. Time intervals and increments in current shall be such that thermal equilibrium between winding temperatures and mounting surface temperatures is achieved as far as is practicable.

During the test, the highest temperature of any part of the surface on which the luminaire is mounted shall be continuously measured. This completes the test for luminaires fitted with thermal links.

For luminaires fitted with manual-reset thermal cut-outs, the test shall be repeated three times, allowing a 30 min interval between tests. At the end of each 30 min interval, the cut-out shall be reset.

For luminaires fitted with auto-reset thermal cut-outs, the test shall be continued until a stable mounting surface temperature is achieved. The auto-reset thermal cut-out shall operate three times by switching the controlgear off and on, under the given conditions.

Associated transformers not tested with their own enclosure shall be subjected to the test since these characteristics are not verified by the component standard.

Compliance is checked as follows.

During the test, the temperature of any part of the mounting surface shall not exceed 135 °C and shall be not more than 110 °C when the protector recloses the circuit (with a resetting type protector) except that:

during any cycle of operation of the protector during the test, the surface temperature may be more than 135 °C, provided that the length of time between the instant when the surface temperature first exceeds the limit and the instant of attainment of the maximum temperature indicated in Table 26 does not exceed the time correspondingly indicated in that table.

Table 26 – Temperature overshoot time limitation

Maximum temperature of the mounting surface °C	Maximum time for attainment of the maximum temperature from 135 °C min
over 180	0
between 175 and 180	15
between 170 and 175	20
between 165 and 170	25
between 160 and 165	30
between 155 and 160	40
between 150 and 155	50
between 145 and 150	60
between 140 and 145	90
between 135 and 140	120

After the test, the following applies.

The highest temperature of any part of the mounting surface shall not exceed 180 °C at any time during tests for thermal links and manual-reset thermal cut-outs, or 130 °C during tests for auto-reset thermal cut-outs.

For track-mounted luminaires, after the test no part of the track shall show symptoms of unsafe deterioration, for example cracks, scorches or deformation.

14.7 Thermal test in regard to fault conditions in controlgear or electronic devices incorporated in thermoplastic luminaires

14.7.1 General

The test applies only to luminaires with a thermoplastic housing not fitted with a mechanical temperature-independent support in accordance with 7.15.2.

This test shall not to be applied to independent transformers provided with their own enclosure, complying with the IEC 61558 series and to independent controlgear with their own enclosure complying with the IEC 61347 series.

14.7.2 Test for luminaires without temperature sensing controls

14.7.2.1 Test for luminaires incorporating ballast(s) of fluorescent lamps with a lamp load ≤ 70 W

Three luminaires shall be tested under the conditions specified in 14.4.2, items a), b), c), e), and h). In addition, the following applies.

The ballast selected for the test (which has the most thermal influence on the fixing points, mounting surface and exposed parts, fitted inside the luminaire according to the luminaire design) shall be supplied directly at 1,1 times the rated voltage for 4 h (conditioning period), in accordance with Figure 44.

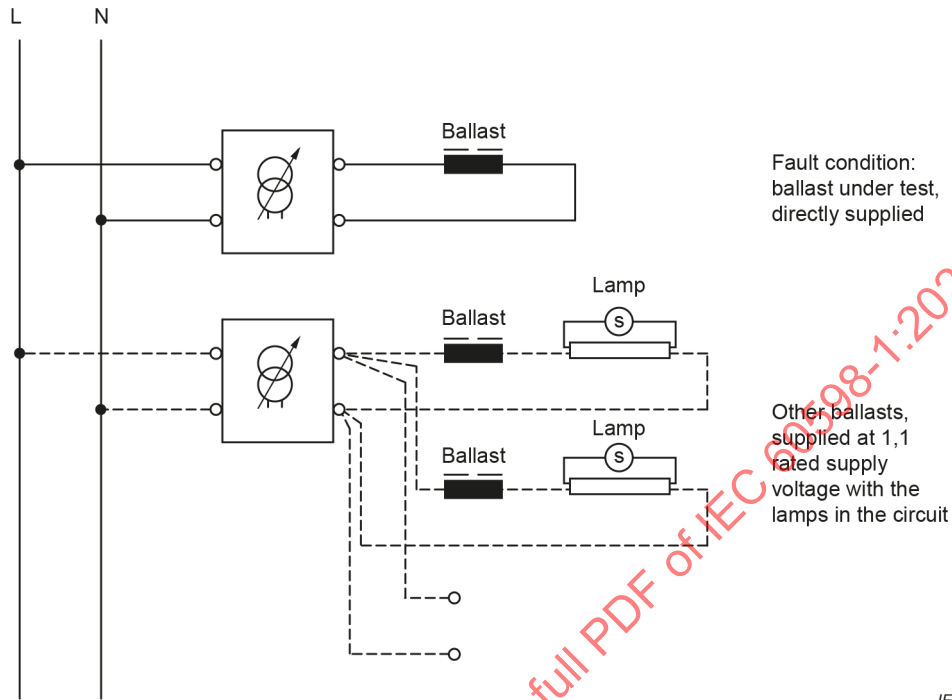

Figure 44 – Test circuit for luminaires incorporating fluorescent lamp ≤ 70 W

If more than one ballast is used inside the luminaire, only one of them shall be checked in fault condition; the other(s) shall be supplied at 1,1 times the rated supply voltage, in normal operation with the relevant lamp(s) in the circuit (up to the end of the test).

Following the first initial conditioning period, the supply voltage to the ballast under test shall be increased by 20 % of the rated supply voltage and left for a period of 15 min. If no failure of the ballast occurs during this period, the supply voltage to the ballast under test shall be increased repeatedly in steps of 10 % of the rated supply voltage at 15 min intervals until ballast failure occurs.

For the circuit not subjected to the test, an increase of the supply voltage during the fault condition shall be avoided (to check this, it is necessary to keep measuring the ballast current). After the ballast failure, the luminaire shall be allowed to cool to ambient temperature.

Electronic controlgear and small wound devices incorporated in them are exempted from these requirements.

Annex S provides an alternative method to the tests specified in Clause 14. The reference method is that given in 14.7.2.1.

In order to perform this fault test, a protection should be used for the supply circuit, but it shall not influence the test result.

Because of the high current that can be present during this test, appropriate protection of the test circuit shall be provided. To ensure that any protection device does not affect the outcome of the test and the ballast breakdown has occurred at the conclusion of the test; it shall be checked that this ballast failure is due to winding rupture. See Figure 44.

A 20 A fuse (with electrical characteristics specified in the IEC 60269 series) may be used.

Following the test, the luminaire shall be inspected to ensure that the components have been retained in place.

Parts of the luminaire enclosure providing protection against electric shock shall continue to protect hazardous live parts against access with the standard test finger (test probe B according to IEC 61032:1997, Figure 2) as specified in Clause 10.

14.7.2.2 Test for luminaires incorporating discharge lamps, fluorescent lamps (> 70 W), transformer of power > 10 VA

The luminaire shall be tested under the conditions specified in 14.4.2, items a), c), e), f) and h). In addition, the following applies:

20 % of the lamp circuits in the luminaire, and not less than one lamp circuit, shall be subjected to abnormal conditions (see 14.5.2, item a)).

The circuit(s) which have the most thermal influence on the fixing point and exposed parts shall be chosen and other lamp circuits shall be operated at rated voltage under normal conditions.

The circuit(s) subjected to abnormal conditions, shall be operated at 0,9, 1,0 and 1,1 times the rated voltage (or the maximum of the rated voltage range). When conditions are stable, the highest winding temperature, the highest temperature of fixing points and the most thermally influenced exposed parts shall be measured. It is not necessary to measure the temperature of small wound devices that are incorporated within electronic circuits.

The values of ambient temperature and the temperature measured at 0,9, 1,0 and 1,1 times the rated voltage (or the maximum of the voltage range) are used for the linear regression formula in calculating the temperature of fixing points and other exposed parts in relation to a ballast or transformer winding temperature of 350 °C. If the difference between winding temperature measurements at 0,9 and 1,1 co-ordinates is less than 30 K, a fourth point is added, whose co-ordinates are winding t_a , fixing or exposed part t_a . The thermoplastic material is then subjected to the ball pressure test as described in 15.2 at the estimated temperature determined by linear regression, but not less than 75 °C. The diameter of the impression shall be measured and shall not exceed 2 mm.

This is a fault condition test and the application of the additional 25 °C to the test temperature of 15.2 does not apply.

NOTE t_a is the rated t_a of the luminaire.

14.7.2.3 Test for luminaires with inherently short-circuit proof transformer of power ≤ 10 VA

The fault test shall be carried out, according to the test method in 14.7.2.2, to small transformers with power up to 10 VA; at the end of the first period of 4 h, with the secondary winding short-circuited, in case of no failure the voltage shall be incremented by the same steps in 14.7.2.1 up to the failure.

The short-circuit current shall be allowed to continue until transformer failure occurs; transformers that are mounted in their own enclosure (e.g. emergency inverter) and have shown to comply with their own relevant safety standard are deemed to comply with 14.7.2.3 without the need for test.

Following the test, the luminaire shall be inspected to ensure that the components have been retained in place.

Parts of the luminaire enclosure providing protection against electric shock shall continue to protect hazardous live parts against access with the standard test finger (test probe B according to IEC 61032:1997, Figure 2), as specified in Clause 10.

Because of the high current that can be present during this test, appropriate protection of the test circuit shall be provided (see 14.7.2.1). It shall be checked that any protection device does not affect the outcome of the test and the transformer breakdown has occurred at the conclusion of the test.

14.7.3 Test for luminaires with temperature sensing controls internal or external to the controlgear or transformer

The luminaires shall be set up for this test as described in the first three paragraphs of 14.7.2.2.

The circuits subjected to abnormal conditions shall be operated with a slowly and steadily increasing current through the windings, until the temperature sensing control operates.

Time intervals and increments in current shall be such that thermal equilibrium between winding temperatures and temperature of fixing points and most thermally influenced exposed parts is achieved as far as practicable. During the test, the highest temperature of the spots tested shall be continuously measured.

For luminaires fitted out with manual-reset thermal cut-outs, the test shall be repeated six times, allowing 30 min intervals between tests. At the end of each 30 min interval, the cut-out shall be reset.

For luminaires fitted with auto-reset thermal cut-outs, the tests shall be continued until a stable temperature is achieved.

In order to perform the test on transformers, see also IEC 61558-1:2017, 15.3.5. The temperature sensing controls external to the transformer shall be checked according to IEC 61558-1:2017, 20.7, 20.8 and 20.9.

The highest temperature of the fixing points and most thermally influenced exposed parts shall be recorded. The thermoplastic material is then subjected to the ball pressure test as described in 15.2 at the maximum recorded temperature, but not less than 75 °C. The diameter of the impression shall be measured and shall not exceed 2 mm.

This is a fault condition test and the application of the additional 25 °C to the test temperature of 15.2.2 does not apply.

NOTE 1 "Fixing points" (in 14.7) means both the fixing points of components and the fixing points of a luminaire to the mounting surface.

NOTE 2 "Exposed part" (in 14.7) means the outer surface of the luminaire enclosure.

NOTE 3 According to the requirements of 14.7, measurement of exposed parts is restricted to those parts providing the luminaire or component fixing or parts providing a protective barrier against accidental contact with hazardous live parts, as required by Clause 10.

NOTE 4 The hottest part of the thermoplastic material section requiring testing is measured. This is often on the internal surface of a luminaire enclosure, not the outer surface.

NOTE 5 The material temperature limits defined are with respect to materials under both mechanical load and no mechanical load.

15 Resistance to heat, fire and tracking

15.1 General

Clause 15 specifies requirements and tests relating to the resistance to heat, fire and tracking of certain parts of the insulating material of luminaires.

For printed wiring boards, reference shall be made to the requirements of the IEC 61249 series.

15.2 Resistance to heat

15.2.1 External parts of insulating material providing protection against electric shock, and parts of insulating material retaining current-carrying parts or SELV or PELV parts in position shall be sufficiently resistant to heat.

The ball pressure test does not have to be applied to plastic parts of a luminaire which provide supplementary insulation.

15.2.2 Compliance is checked by the following test.

The test is not made on parts of ceramic material or on the insulation of wiring.

The test shall be made in a heating cabinet having a temperature of $25\text{ °C} \pm 5\text{ °C}$ in excess of the operating temperature of the relevant part determined during the temperature test (normal operation) of Clause 14, with a minimum temperature of 125 °C when parts retaining current-carrying parts or SELV or PELV parts in position are tested, and 75 °C for other parts.

The surface of the part to be tested shall be placed in the horizontal position and a steel ball of 5 mm diameter pressed against this surface with a force of 20 N. A suitable apparatus for this test is shown in Figure 45. If the surface under test bends, the part where the ball presses should be supported.

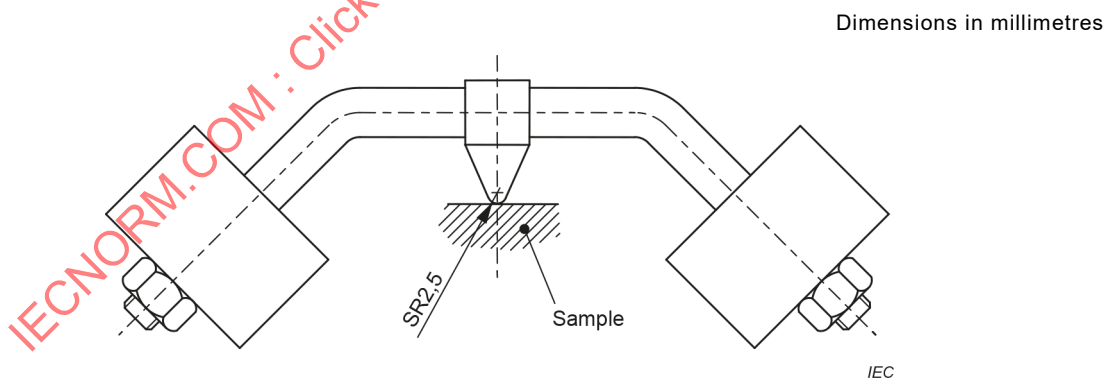

Figure 45 – Ball-pressure apparatus

The specimen shall be at least 2,5 mm thick, but if such a thickness is not available on the specimen then two or more pieces are placed (stacked) together.

After 1 h, the ball shall be removed from the sample, and the sample shall be cooled by immersion in cold water for 10 s. The diameter of the impression shall be measured and shall not exceed 2 mm.

15.3 Resistance to flame and ignition

15.3.1 Parts of insulating material retaining current-carrying parts in position, and external parts of insulating material providing protection against electric shock shall be resistant to flame and ignition.

For materials other than ceramic, compliance is checked by the test of 15.3.2 or 15.3.3, as appropriate.

15.3.2 *Parts of insulating material retaining current-carrying parts in position shall withstand the following tests. The parts to be tested are subjected to the needle-flame test of IEC 60695-11-5, the test flame being applied to the sample for 10 s at the point where the highest temperatures are likely to occur, measured if necessary during the thermal tests of Clause 14.*

The duration of burning shall not exceed 30 s after removal of the test flame, and any burning drop from the sample shall not ignite the underlying parts as required by IEC 60695-11-5.

The requirements of 15.3.2 do not apply in those cases where the luminaire provides an effective barrier to burning drops.

15.3.3 *Parts of insulating material which do not retain current carrying parts in position, but which provide protection against electric shock shall withstand the following test.*

Parts are subjected to a test using a nickel-chromium glow-wire heated to 650 °C. The test apparatus and test procedure shall be those described in IEC 60695-2-11.

Any flame or glowing of the sample shall extinguish within 30 s of withdrawing the glow-wire, and any burning or molten drop shall not ignite the underlying parts specified in IEC 60695-2-11.

The requirements of 15.3.3 do not apply in those cases where the luminaires provide an effective barrier to burning drops or where the insulation material is ceramic.

15.4 Resistance to tracking

15.4.1 Insulating parts of luminaires, which are other than ordinary luminaires, which retain current-carrying parts or SELV or PELV parts in position or are in contact with such parts, shall be of material resistant to tracking unless they are protected against dust and moisture.

15.4.2 *Compliance is checked by the following test, which is made at three places on the test sample.*

For materials other than ceramic, compliance is checked by the proof tracking test in accordance with IEC 60112 subject to the following details.

- If the specimen has no flat surface of at least 15 mm × 15 mm, the test may be carried out on a flat surface with reduced dimensions provided drops of liquid do not flow off the specimen during the test. No artificial means should, however, be used to retain the liquid on the surface. In case of doubt, the test may be made on a separate strip of the same material, having the required dimensions and manufactured by the same process.*
- If the thickness of the specimen is less than 3 mm, two, or if necessary more, specimens should be stacked to obtain a thickness of at least 3 mm.*
- The test shall be made at three places of the specimen or on three specimens.*
- Test solution A, described in IEC 60112:2020, 7.3, shall be used.*

15.4.3 The specimen shall withstand 50 drops without failure at a test voltage of PTI 175.

A failure has occurred if a current of 0,5 A or more flows for at least 2 s by a conducting path between the electrodes on the surface of the specimen, thus operating the overcurrent relay, or if the specimen burns without releasing the overcurrent relay.

IEC 60112:2020, Clause 9 regarding the determination of erosion does not apply.

16 Screw terminals

16.1 General

Clause 16 specifies requirements for all types of terminals which employ screws incorporated in luminaires.

Examples of screw terminals are shown in Figure 46 to Figure 50.

IECNORM.COM : Click to view the full PDF of IEC 60598-1:2024

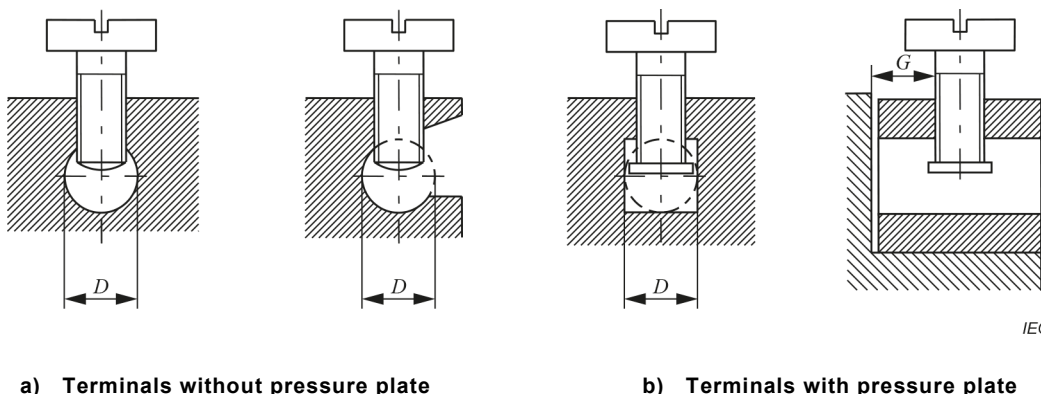

Key

D conductor space

G distance between clamping screw and end of conductor when fully inserted

The shape of the conductor space may differ from those shown, provided a circle with a diameter equal to the minimum value specified for *D* can be inscribed.

NOTE The part of the terminal containing the threaded hole and the part of the terminal against which the conductor is clamped by the screw can be two separate parts, as in the case of terminals provided with a stirrup.

Terminal size	Minimum diameter <i>D</i> of conductor space mm	Minimum distance <i>G</i> between clamping screw and end of conductor when fully inserted mm		Torque Nm					
				I ^a		III ^a		IV ^a	
				One screw	Two screws	One screw	Two screws	One screw	Two screws
1	2,5	1,5	1,5	0,2	0,2	0,4	0,4	0,4	0,4
2	3,0	1,5	1,5	0,25	0,2	0,5	0,4	0,5	0,4
3	3,6	1,8	1,5	0,4	0,2	0,8	0,4	0,8	0,4
4	4,0	1,8	1,5	0,4	0,25	0,8	0,5	0,8	0,5
5	4,5	2,0	1,5	0,7	0,25	1,2	0,5	1,2	0,5
6	5,5	2,5	2,0	0,8	0,7	2,0	1,2	2,0	1,2
7	7,0	3,0	2,0	1,2	0,7	2,5	1,2	3,0	1,2

^a The values specified apply to the screws covered by the corresponding columns in Table 30.

Figure 46 – Pillar terminals

Screw not requiring washer or clamping plate

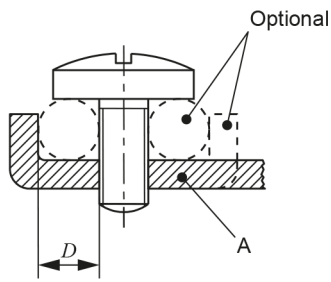

Screw requiring washer or clamping plate

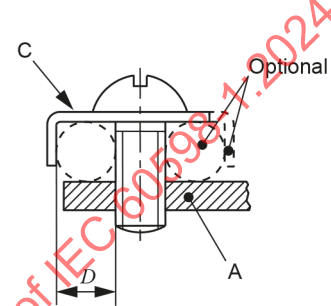
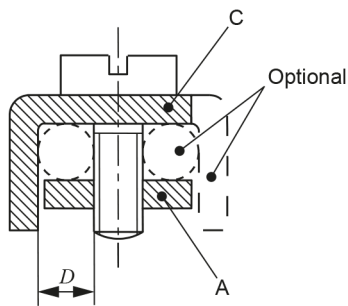
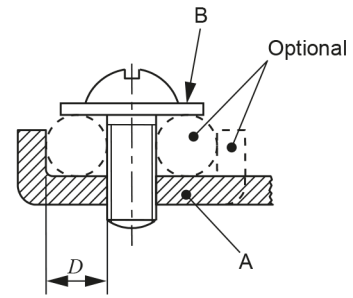

Screw terminals

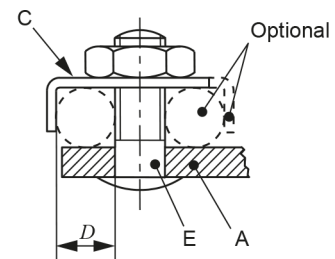
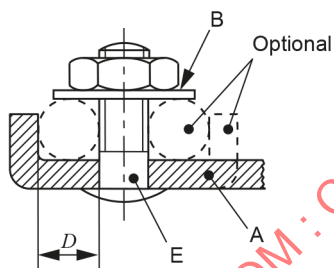

Stud terminals

IEC

Key

- A fixed part
- B washer or clamping plate
- C anti-spread device
- D conductor space
- E stud

NOTE The part which retains the conductor in position can be of insulating material provided the pressure necessary to clamp the conductor is not transmitted through the insulating material.

Terminal size	Minimum diameter <i>D</i> of conductor space mm	Torque Nm			
		III ^a		IV ^a	
		One screw	Two screws	One screw or stud	Two screws or studs
0	1,4	0,4	–	0,4	–
1	1,7	0,5	–	0,5	–
2	2,0	0,8	–	0,8	–
3	2,7	1,2	0,5	1,2	0,5
4	3,6	2,0	1,2	2,0	1,2
5	4,3	2,0	1,2	2,0	1,2
6	5,5	2,0	1,2	2,0	1,2
7	7,0	2,5	2,0	3,0	2,0

^a The values specified apply to the screws covered by the corresponding columns in Table 30.

Figure 47 – Screw terminals and stud terminals

IECNORM.COM : Click to view the full PDF of IEC 60598-1:2024

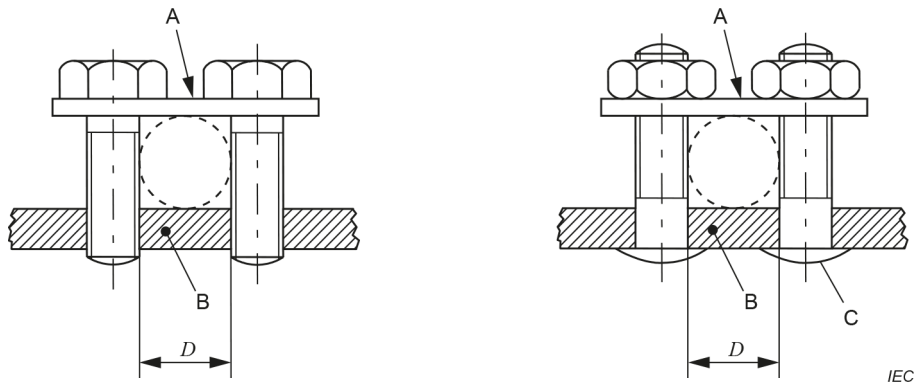
**Key**

- A saddle
- B fixed part
- C stud
- D conductor space

NOTE The shape of the section of the conductor space can differ from those shown in the figures, provided a circle with a diameter equal to the minimum value specified for D can be inscribed.

The shape of the upper and lower faces of the saddle can be different, to accommodate conductors of either small or large cross-sectional area, by reversing the saddle.

The terminals can have more than two clamping screws or studs.

Terminal size	Minimum diameter D of conductor space mm	Torque Nm
3	3,0	0,5
4	4,0	0,8
5	4,5	1,2
6	5,5	1,2
7	7,0	2,0

Figure 48 – Saddle terminals

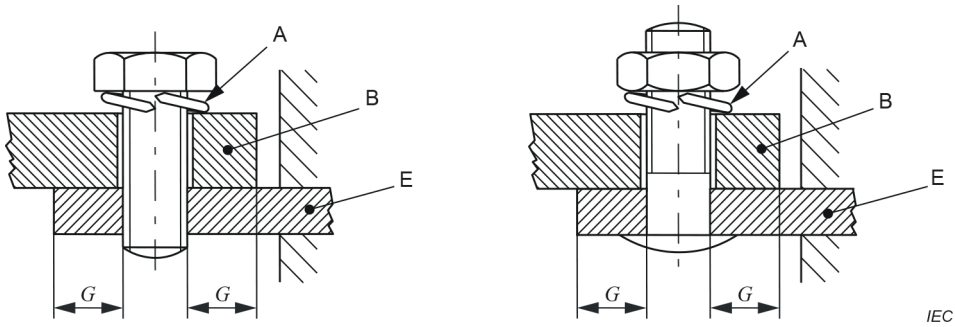

Key

- A locking means
- B cable lug or bar
- E fixed part
- F stud
- G distance between edge of hole and side of clamping area

For certain types of equipment, the use of terminals of a size smaller than those specified is allowed.

Terminal size	Minimum distance <i>G</i> between edge of hole and side of clamping area mm	Torque Nm	
		III ^a	VI ^a
6	7,5	2,0	2,0
7	9,0	2,5	3,0

^a The values specified apply to the studs covered by the corresponding columns in Table 30.

Figure 49 – Lug terminals

IECNORM.COM : Click to view the full PDF of IEC 60598-1:2024

**Key**

A fixed part

D conductor space

Terminal size	Minimum diameter D of conductor space ^a	Minimum distance between fixed part and end of conductor when fully inserted
	mm	mm
0	1,4	1,5
1	1,7	1,5
2	2,0	1,5
3	2,7	1,8
4	3,6	1,8
5	4,3	2,0
6	5,5	2,5
7	7,0	3,0

^a The torque value to be applied is that specified in column II or V of Table 30 as appropriate.

Figure 50 – Mantle terminals**16.2 General requirements and basic principles**

16.2.1 These requirements apply to terminals with screw clamping carrying a current not exceeding 63 A, intended for the connection, by clamping only, of copper conductors of cables and flexible cords.

These requirements do not exclude terminals of types other than those shown in Figure 46 to Figure 50.

16.2.2 Terminals shall comply with the requirements of 16.2.2.1 to 16.2.2.4.

16.2.2.1 Terminals are of varied design and have different shapes: they include, among others, terminals in which the conductor is clamped directly or indirectly under the shank of the screw, terminals in which the conductor is clamped directly or indirectly under the head of the screw, terminals in which the conductor is clamped directly or indirectly under a nut, and terminals intended solely for use with cable lugs or bars.

The basic principles governing these requirements are specified in 16.2.2.2 to 16.2.2.4.

16.2.2.2 Terminals are primarily for the connection of only one conductor, although, owing to the wide range of conductors that each terminal is required to clamp, they may in some cases be suitable for clamping two conductors having the same nominal cross-sectional area, which is smaller than the maximum value for which the terminal is designed.

Certain types of terminals, in particular pillar terminals and mantle terminals, may be used for looping-in, when two or more conductors of the same or different nominal cross-sectional area or composition have to be connected. In such cases, it is possible that the terminal sizes specified in this document will not be applicable.

16.2.2.3 In general, terminals will be suitable for the connection of cables and flexible cords without special preparation of the conductor, but provision is made in certain cases for connection by means of cable lugs or for connection to bars.

16.2.2.4 A numerical classification for terminals is adopted, based on the nominal cross-sectional areas of the conductors that the terminal can accept. According to this classification, each terminal can accept any one of three successive sizes of conductors in the range of nominal cross-sectional areas specified in the IEC 60227 series or the IEC 60245 series.

With one exception, the sizes of the conductors within each range advance by one step for each increase in the size of the terminal.

The nominal cross-sectional areas of the conductors assigned to each terminal are given in Table 27, which also gives the diameter of the largest conductor that each terminal can accept.

Terminals may be used with conductors smaller than the nominal given range, provided the conductor is clamped with sufficient pressure to ensure adequate electrical and mechanical connection.

Table 27 – Nominal cross-sectional areas of conductors according to terminal sizes

Terminal size	Flexible conductors				Rigid conductors, solid or stranded			
	Nominal cross-sectional areas mm ²			Diameter of largest conductor mm	Nominal cross-sectional areas mm ²			Diameter of largest conductor mm
0 ^a	0,5	0,75	1	1,45	–	–	–	–
1 ^b	0,75	1	1,5	1,73	0,75	1	1,5	1,45
2	1	1,5	2,5	2,21	1	1,5	2,5	2,13
3	1,5	2,5	4	2,84	1,5	2,5	4	2,72
4 ^c	2,5	4	6	3,87	2,5	4	6	3,34
5	2,5	4	6	4,19	4	6	10	4,32
6	4	6	10	5,31	6	10	16	5,46
7	6	10	16	6,81	10	16	25	6,83

^a Not suitable for rigid conductors. Suitable for flexible conductors of 0,4 mm² cross-sectional area (see 8.3.1).

^b Also suitable for flexible conductors having a nominal cross-sectional area of 0,5 mm² if the end of the conductor is folded back on itself.

^c Not suitable for 6 mm² flexible conductors of some special constructions.

16.2.3 Terminals shall allow the proper connection of copper conductors having nominal cross-sectional areas as given in Table 28 and the conductor space shall be at least that given in Figure 46, Figure 47, Figure 48 or Figure 50, as appropriate.

These requirements do not apply to lug terminals.

Table 28 – Nominal cross-sectional areas of conductors according to maximum current

Maximum current carried by the terminal A	Flexible conductors		Rigid conductors solid or stranded	
	Nominal cross-sectional areas ^a mm ²	Terminal size	Nominal cross-sectional areas ^a mm ²	Terminal size
2	0,4	0	–	–
6	0,5 to 1	0	0,75 to 1,5	1
10	0,75 to 1,5	1	1 to 2,5	2
16	1 to 2,5	2	1,5 to 4	3
20	1,5 to 4	3	1,5 to 4	3
25	1,5 to 4	3	2,5 to 6	4
32	2,5 to 6	4 or 5 ^b	4 to 10	5
40	4 to 10	6	6 to 16	6
63	6 to 16	7	10 to 25	7

^a These requirements do not apply to terminals used for the interconnections of different components of luminaires by means of cables or flexible cords not complying with the IEC 60227 series or the IEC 60245 series, if the other requirements of this document are met.

^b Terminal size 4 is not suitable for 6 mm² of flexible conductors of some special constructions, in which case terminal size 5 should be used.

Compliance is checked by inspection, by measurement and by fitting conductors of the smallest and largest cross-sectional areas specified.

16.2.4 Terminals shall provide adequate connection of the conductors.

Compliance is checked by carrying out all tests of 16.3.

16.3 Mechanical requirements and tests

16.3.1 For pillar terminals, the distance between the clamping screw and the end of the conductor, when fully inserted, shall be at least that given in Figure 46.

The minimum distance between the clamping screw and the end of the conductor applies only to pillar terminals through which the conductor cannot pass.

For mantle terminals, the distance between the fixed part and the end of the conductor, when fully inserted, shall be at least that given in Figure 50.

Compliance is checked by measurement, after a solid conductor of the largest cross-sectional area given in Table 28 has been fully inserted and fully clamped.

16.3.2 Terminals shall be so designed or placed that neither a solid conductor nor a strand of a stranded conductor can slip out while the clamping screws or nuts are being tightened.

This requirement does not apply to lug terminals.

For fixed luminaires intended solely for permanent connection to fixed (external) wiring, this requirement applies only to the use of solid or rigid stranded conductors. The test is made with rigid stranded conductors.

Compliance is checked by the following test.

Terminals are fitted with a conductor having the composition given in Table 29.

Table 29 – Composition of conductors

Terminal size	Number of strands and nominal diameter of strands <i>n</i> × mm	
	Flexible conductors	Rigid stranded conductors
0	32 × 0,20	–
1	30 × 0,25	7 × 0,50
2	50 × 0,25	7 × 0,67
3	56 × 0,30	7 × 0,85
4	84 × 0,30	7 × 1,04
5	84 × 0,30	7 × 1,35
6	80 × 0,40	7 × 1,70
7	126 × 0,40	7 × 2,14

Before insertion in the terminal, strands of rigid conductors are straightened and flexible conductors are twisted in one direction so that there is a uniform twist of one complete turn in a length of approximately 20 mm.

The conductor is inserted in the terminal for the minimum distance specified or, where no distance is specified, until it just projects from the far side of the terminal and in the position most likely to allow the strand to slip out. The clamping screw is then tightened with a torque equal to two-thirds of that given in the appropriate column of Table 30.

For flexible conductors, the test is repeated with a new conductor which is twisted as before, but in the opposite direction.

After the test, no strand of the conductor shall have slipped out through the gap between the clamping means and the retaining device.

16.3.3 Terminal sizes up to and including size 5 shall allow the conductor to be connected without special preparation.

Compliance is checked by inspection.

NOTE The term "special preparation" covers the application of additional solder to the strands of the conductor, use of cable lugs, formation of eyelets, etc., but not the reshaping of the conductor for its introduction into the terminal or the twisting of a stranded conductor to consolidate the end.

The bonding together by heating of the tinned strands of a flexible conductor without the addition of solder is not considered special preparation.

16.3.4 Terminals shall have adequate mechanical strength.

Screws and nuts for clamping the conductors shall have a metric ISO thread. Terminals for external wiring shall not serve to fix any other component, except that they may also clamp internal conductors if these are so arranged that they are unlikely to be displaced when fitting external conductors.

Screws shall not be of a metal which is soft or liable to creep, such as zinc or aluminium.

Compliance is checked by inspection and by the tests of 16.2.3, 16.3.6, 16.3.7 and 16.3.8.

16.3.5 Terminals shall be resistant to corrosion.

Compliance is checked by the corrosion test specified in Clause 7.

16.3.6 Terminals shall be fixed to the luminaire or to a terminal block or otherwise fixed in position. When the clamping screws or nuts are tightened or loosened, the terminals shall not work loose, internal wiring shall not be subjected to stress, and creepage distances and clearances shall not be reduced below the values specified in Clause 13.

These requirements do not imply that the terminals should be so designed that their rotation or displacement is prevented, but any movement shall be sufficiently limited so as to ensure compliance with this document.

Covering with sealing compound or resin is sufficient to prevent a terminal from working loose, provided that the sealing compound or resin is not subject to stress during normal use and the effectiveness of the sealing compound or resin is not impaired by temperatures attained by the terminal under the most unfavourable conditions specified in Clause 14.

Compliance is checked by inspection, by measurements and by the following test.

A rigid copper conductor of the largest cross-sectional area given in Table 28 is placed in the terminal. Screws and nuts are tightened and loosened five times by means of a suitable test screwdriver or wrench, the torque applied when tightened being equal to that given in the appropriate column of Table 30 or in the appropriate table of Figure 46, Figure 47, Figure 48, Figure 49 or Figure 50 whichever is the higher.

Table 30 – Torque to be applied to screws and nuts

Nominal diameter of thread mm	Torque Nm				
	I	II	III	IV	V
Up to and including 2,8	0,2	–	0,4	0,4	–
Over 2,8 up to and including 3,0	0,25	–	0,5	0,5	–
Over 3,0 up to and including 3,2	0,3	–	0,6	0,6	–
Over 3,2 up to and including 3,6	0,4	–	0,8	0,8	–
Over 3,6 up to and including 4,1	0,7	1,2	1,2	1,2	1,2
Over 4,1 up to and including 4,7	0,8	1,2	1,8	1,8	1,8
Over 4,7 up to and including 5,3	0,8	1,4	2,0	2,0	2,0
Over 5,3 up to and including 6,0	–	1,8	2,5	3,0	3,0
Over 6,0 up to and including 8,0	–	2,5	3,5	6,0	4,0
Over 8,0 up to and including 10,0	–	3,5	4,0	10,0	6,0
Over 10,0 up to and including 12,0	–	4,0	–	–	8,0
Over 12,0 up to and including 15,0	–	5,0	–	–	10,0

The conductor is moved each time the screw or nut is loosened.

Column I applies to screws without heads if the screw, when tightened, does not protrude from the hole, and to other screws which cannot be tightened by means of a screwdriver with a blade wider than the diameter of the screw.

Column II applies to nuts of mantle terminals with cap nuts which are tightened by means of a screwdriver.

Column III applies to other screws which are tightened by means of a screwdriver.

Column IV applies to screws and nuts, other than nuts of mantle terminals, which are tightened by means other than a screwdriver.

Column V applies to nuts of mantle terminals in which the nut is tightened by means other than a screwdriver.

Where a screw has a hexagonal head with means for tightening with a screwdriver and the values in columns III and IV are different, the test is made twice, first applying to the hexagonal head the torque given in column IV, and then on another set of samples, applying the torque given in column III by means of a screwdriver. If the values in columns III and IV are the same, only the test with the screwdriver is made.

During the test, terminals shall not work loose and there shall be no damage, such as breakage of screws or damage to the head slots, threads, washers or stirrups that will impair the further use of the terminals.

For mantle terminals, the specific nominal diameter is that of the slotted stud. The shape of the blade of the test screwdriver shall suit the head of the screw to be tested. The screws and nuts shall not be tightened in jerks.

16.3.7 Terminals shall clamp the conductor reliably between metal surfaces.

For lug terminals, a spring washer, or equally effective locking means, shall be provided and the surface within the clamping area shall be smooth.

For mantle terminals, the bottom of the conductor space shall be slightly rounded in order to obtain a reliable connection.

Compliance is checked by inspection and by the following test.

The terminals are fitted with rigid conductors of the smallest and largest cross-sectional areas given in Table 28, the terminal screws being tightened with a torque equal to two-thirds of that given in the appropriate column of Table 30.

If the screw has a hexagonal head with a slot, the torque applied is equal to two-thirds of that given in column III of Table 30.

Each conductor is then subjected to a pull of the value, in newtons, given in Table 31; the pull is applied without jerks, for 1 min, in the direction of the axis of the conductor space.

Table 31 – Pull to be applied to conductor

Terminal size	0	1	2	3	4	5	6	7
Pull (N)	30	40	50	50	60	80	90	100

During the test, the conductor shall not move noticeably in the terminal.

16.3.8 Terminals shall clamp the conductor without undue damage to the conductor.

Compliance is checked by inspection of the conductors, after conductors of the smallest and largest cross-sectional areas given in Table 28 have been clamped once and loosened, the torque applied to clamp the conductor being equal to two-thirds of that given in Table 30.

If the screw has a hexagonal head with a slot, the torque applied is equal to two-thirds of that given in column IV of Table 30.

Conductors are unduly damaged if they show deep or sharp indentations.

17 Screwless terminals and electrical connections

17.1 General

Clause 17 specifies requirements for all types of terminals and electrical connections, that do not employ screws, for solid or stranded copper conductors up to 2,5 mm² for internal wiring of luminaires and for connections to external wiring of luminaires.

Some examples of screwless terminals and electrical connections are shown in Figure 51, Figure 52 and Figure 53. IEC 61210 provides further examples of screwless terminals and electrical connections.

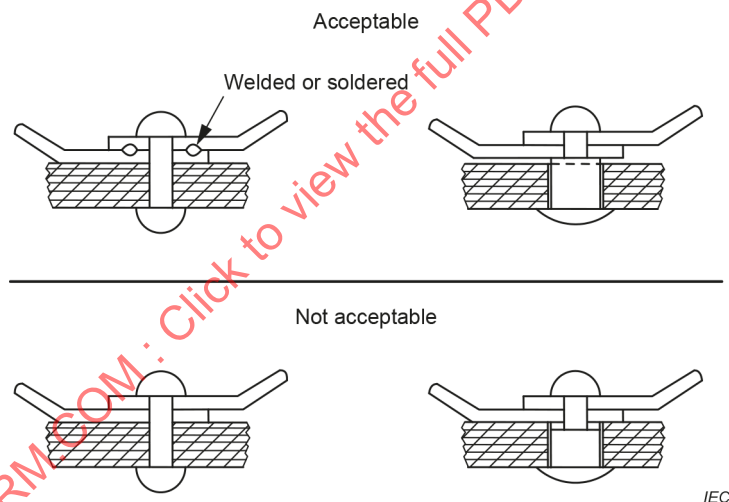
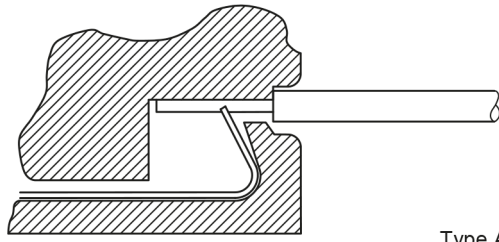
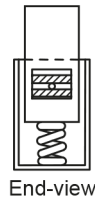

Figure 51 – Construction of electrical connections

Acceptable



Type A



End-view

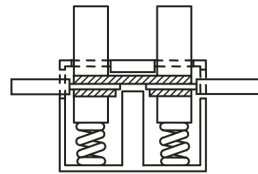

Side-view

Type B

Not acceptable

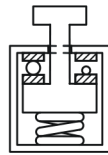

End-view

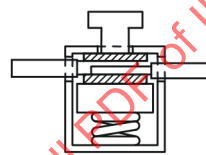

Side-view

IEC

Figure 52 – Examples of spring-type screwless terminals

IECNORM.COM : Click to view the full PDF of IEC 60598-1:2024

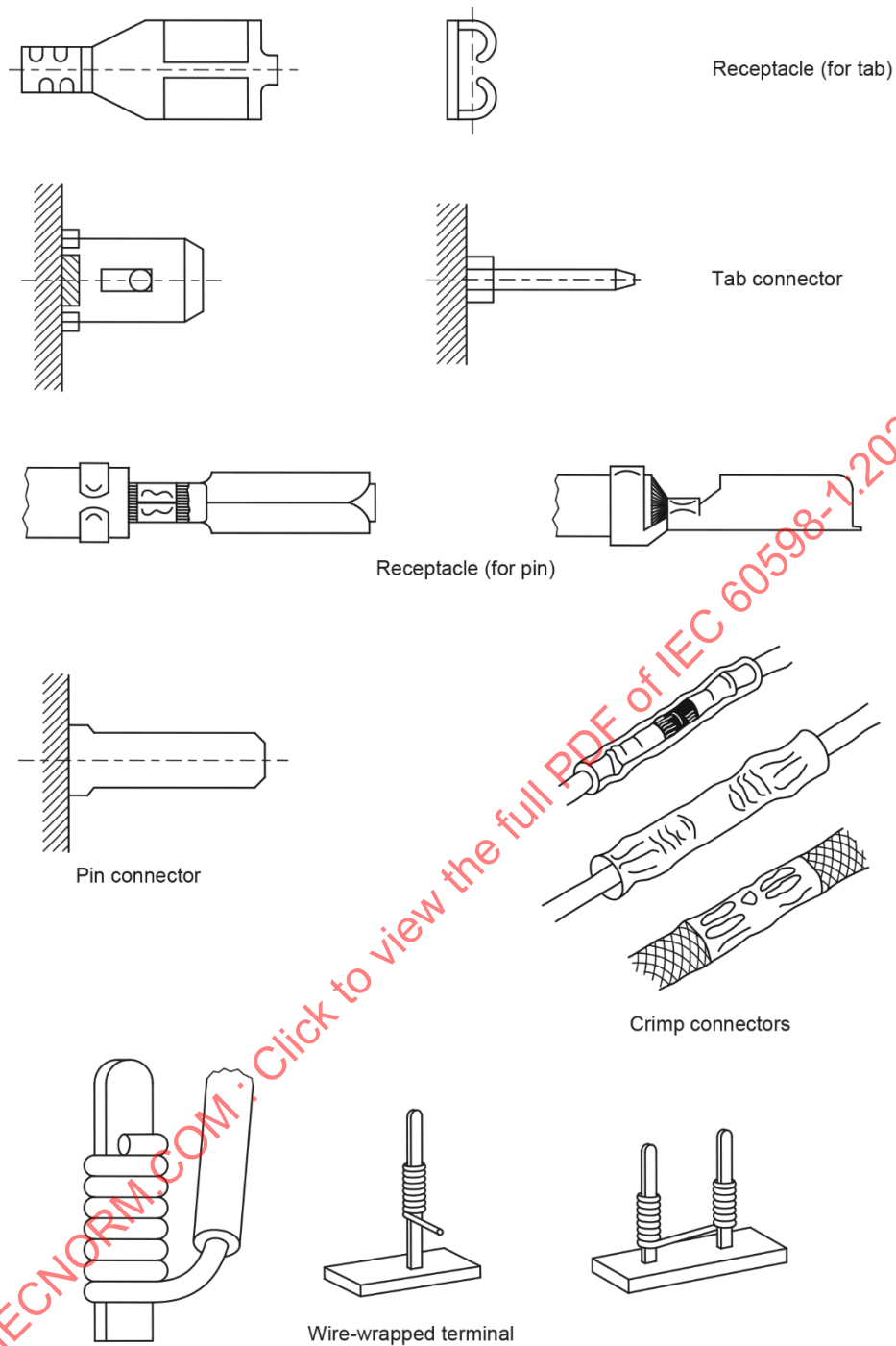

Figure 53 – Further examples of screwless terminals

17.2 General requirements

17.2.1 Parts of terminals or connections for carrying current shall be made of one of the following materials:

- copper;
- an alloy containing at least 58 % copper for parts that are worked cold or at least 50 % copper for other parts;
- another metal having corrosion resistance and mechanical properties no less suitable than copper.

17.2.2 Terminals and connections shall clamp the conductor with sufficient pressure and without undue damage to the conductor.

The conductor shall be clamped between metal surfaces. However, terminals for circuits having a rated current not exceeding 2 A may have one non-metallic surface if the requirements of 17.2.5 are met.

Insulation piercing terminals are only acceptable for the creation of a branch connection in SELV or PELV circuits of luminaires or other luminaires as non-rewireable, permanent connections.

17.2.3 Terminals shall be so designed that, when the conductor has been adequately inserted into the terminal, further insertion of its end is prevented by a stop.

17.2.4 Terminals other than those for lead assemblies shall accept "non-prepared conductors" (see 3.114).

Compliance with the requirements of 17.2.2, 17.2.3 and 17.2.4 is checked by inspection of the terminals or connections, after fitting with appropriate conductors, and after the heating test of 17.4 or 17.5. For 17.2.2 conductors are unduly damaged if they show deep or sharp indentations.

17.2.5 Electrical connections shall be so designed that the pressure essential for good electrical conductivity is not transmitted through insulating material other than ceramic, pure mica, or other material with characteristics no less suitable, unless there is sufficient resilience in the metallic parts to compensate for any possible shrinking of the insulating material (see Figure 51 and Figure 52).

17.2.6 It shall be clear how the connection of the conductor to, and the disconnection from, spring-type non-permanent screwless terminals is effected.

The disconnection of a conductor shall require an operation other than a pull of the conductor and shall be such that it can be made by hand or with the aid of a simple, generally available device.

17.2.7 Terminals for connection to several conductors under spring clamps shall clamp each conductor independently.

For terminals designed for non-permanent connections, it shall be possible to withdraw the conductors together or separately.

17.2.8 Terminals shall be suitably fixed to the equipment (e.g. luminaire or controlgear) or to a terminal block or otherwise fixed in position. They shall not work loose when conductors are inserted or withdrawn.

Compliance is checked by inspection and, if there is a doubt, by applying the mechanical test given in 17.4.1 or 17.5.2. During the test, the terminals shall not work loose and there shall be no damage that will impair their further use.

The above conditions apply not only to terminals which are fixed to equipment but also to terminals which are delivered separately. Covering with sealing compound without other means of locking is not sufficient. Self-hardening resins may however be used to lock terminals which are not subject to torsion in normal use.

17.2.9 Terminals and connections shall withstand the mechanical, electrical and thermal stresses occurring in normal use.

Compliance is checked by the tests of 17.4 or 17.5, as appropriate.

17.2.10 Manufacturers shall declare the conductor size or sizes for which the component is designed and the type of conductor, for example, solid or stranded.

17.3 General instructions for tests

17.3.1 Preparation of samples

The tests for ingress of dust and moisture of Clause 11, if appropriate, shall be carried out before testing terminals or connections contained within the luminaires.

17.3.2 Test conductors

Tests shall be carried out with copper conductors of the types and dimensions recommended by the manufacturer. If a range of conductors is specified, the smallest and largest shall be selected for testing.

17.3.3 Multi-conductor terminals

Screwless terminals having provision for the simultaneous connection of several conductors shall be tested with the number of conductors indicated in the data provided by the manufacturer.

17.3.4 Multi-way terminals

Each terminal in a group or strip of terminals, for example, a terminal block on a controlgear, may be used as a separate sample.

17.3.5 Test quantities

The tests described in 17.4 to 17.5 are carried out on four terminals (or connections). At least three terminals shall meet the requirements. If one terminal fails, four further terminals are tested and these shall meet the requirements.

The tests described in 17.5.3 are carried out on ten terminals.

17.4 Terminal and connections for internal wiring

17.4.1 Mechanical tests

17.4.1.1 General

Terminals and connections shall have adequate mechanical strength.

Compliance is checked by the tests of 17.4.1.2 or 17.4.1.3 as appropriate.

17.4.1.2 Non-permanent connections

17.4.1.2.1 *The mechanical strength of the terminals (or connections) is checked on a set of four terminals. If all the terminals contained within the luminaire are not of the same design, one set of four terminals of each design is subjected to the test.*

This test shall only be applied to devices on which the user may work to complete the assembly of the luminaire before it is put into service.

17.4.1.2.2 *In the case of spring-type terminals (see Figure 52), the test is made with solid copper conductors of the size or sizes specified by the manufacturer. If a range of conductors is specified, two of the terminals are tested with conductors having the smallest cross-sectional area and the two remaining terminals with conductors having the largest cross-sectional area.*

These conductors are connected to, and disconnected from, each terminal five times. For the first four connections, new conductors are used each time. For the fifth connection, the same conductor is used as for the fourth connection and it is clamped at the same place. For each connection, the conductors are pushed into the terminals as far as the stop.

If the terminal is suitable for stranded conductors, an additional test is then made with one rigid stranded copper conductor. If, however, a range of conductors is specified, those with the smallest and largest cross-sectional areas are selected for testing. Each conductor is subjected to only one connection and disconnection with the corresponding terminal used for the testing with solid conductors.

After the final connection, each conductor is subjected to a test pull of 4 N.

17.4.1.2.3 *Pin or tab and receptacle type connections are also subjected to a test pull of 4 N.*

The pull is applied without jerks, for 1 min, in the direction opposite to that used for the application or insertion of the pin or tab and receptacle.

During the test, the conductor or lead assembly shall not move from the pin or tab and receptacle and neither the pin or tab nor the receptacle shall undergo any alteration impairing its future use.

The maximum insertion force between pin or tab and receptacle shall not exceed 50 N and the force for disconnection shall not exceed 50 N.

17.4.1.3 Permanent connections

The connection shall remain fully effective when a pull-off force of 20 N is applied, for 1 min, in a direction opposite to that used for the application or insertion of the conductors.

In some cases, a special tool may be used to apply the force correctly (e.g. in the case of wire-wrapped terminals).

Multi-conductor terminals are tested with the above force applied to each conductor in turn.

17.4.2 Electrical tests

17.4.2.1 General

Terminals and connections shall have adequate electrical performance.

Compliance is checked by the tests of 17.4.2.2 and 17.4.2.3.

17.4.2.2 Contact resistance test

17.4.2.2.1 *The electrical performance of terminals (or connections) is checked on a set of four terminals. If all the terminals contained within the luminaire are not of the same design, one set of four terminals of each design is subjected to the test.*

17.4.2.2.2 *For spring-type terminals, the test according to 17.4.2.2.4 is made with four solid copper non-insulated conductors.*

If a range of conductors is specified, two of the terminals are tested with conductors having the smallest cross-sectional area and the two remaining terminals with conductors having the largest cross-sectional area.

17.4.2.2.3 *In the case of pin or tab and receptacle type terminals, the test of 17.4.2.2.4 is made with lead assemblies.*

17.4.2.2.4 Each terminal with its conductor is loaded with the test current (AC or DC) and after 1 h, the voltage drop across the terminal, still at the test current, is measured. The measuring points are located as close as possible to the contact point across which the voltage drop is being measured. The measured voltage drop shall not exceed 15 mV.

The voltage drop for each joint or contact is considered separately; for example, the junction of the conductor to receptacle is considered separately from the junction of receptacle to pin.

The total voltage drop of two inseparable joints, when measured together, shall not exceed twice the value given in this Subclause 17.4.2.2.4.

17.4.2.3 Heating tests

17.4.2.3.1 Terminals (or connections) with a rated current up to and including 6 A are then subjected to an ageing test, without current, of 25 cycles duration, each cycle comprising 30 min at a temperature of $T \pm 5\text{ °C}$ or $100\text{ °C} \pm 5\text{ °C}$, whichever is the higher, followed by a cooling down period to a temperature between 15 °C and 30 °C . Terminals (or connections) with a rated current exceeding 6 A are subjected to an ageing test of 100 such cycles.

The temperature T is the marked maximum rated temperature for T -marked components such as lampholders.

17.4.2.3.2 The voltage drop is again measured on each terminal:

- a) after the 10th and 25th cycles for terminals with a rated current up to and including 6 A;
- b) after the 50th and 100th cycles for terminals with a rated current greater than 6 A.

If, for all terminals, the voltage drop, in both cases, does not exceed by more than 50 % the voltage drop measurements on the same terminal tested under 17.4.2.2, or if the increase in voltage drop is less than 2 mV, the terminals comply with the requirement.

If the voltage drop of any of the terminals exceeds 22,5 mV, the terminals are rejected.

If, for one of the terminals, the voltage drop measured under a) or b) exceeds by more than 50 %, with a minimum of 2 mV, the voltage drop measured on the same terminal under 17.4.2.2 but does not exceed 22,5 mV, the four terminals are subjected to a new ageing test, according to current rating, of 25 cycles or 100 cycles duration without current.

After the 10th and 25th or 50th and 100th cycles (according to current rating), the voltage drops are again measured. For any terminal, the voltage drop shall not exceed 22,5 mV.

The total voltage drop of two inseparable joints, when measured together, shall not exceed twice the values given in this Subclause 17.4.2.3.2.

17.4.2.3.3 If a terminal is so designed that the conductor is tightened against a surface of insulating material, this surface shall not be deformed during these heating tests.

Compliance is checked by inspection.

17.5 Terminals and connections for external wiring

17.5.1 Conductors

Spring-type terminals shall be suitable for the connection of rigid conductors, solid or stranded, with the nominal cross-sectional areas given in Table 32.

Table 32 – Conductor rating

Maximum rated current of terminals A	Nominal cross-sectional areas of conductors mm ²
6	0,5 to 1
10	> 1 to 1,5
16	> 1,5 to 2,5

NOTE Terminals are usually referred to by a designation. Size 0, for example, is generally a 6 A rating. If the component rating is less than the technical capacity, the component rating is used.

Compliance is checked by inspection, by measurement and by fitting conductors of the smallest and largest cross-sectional areas specified.

17.5.2 Mechanical tests

17.5.2.1 Terminals and connections shall have adequate mechanical strength.

Compliance is checked by the tests of 17.5.2.2 and 17.5.2.3, which are made on one terminal of each of four samples.

17.5.2.2 *In the case of spring-type terminals, the test is made alternately with solid copper conductors having the largest and then the smallest cross-sectional areas specified in 17.5.1. These conductors are connected to, and disconnected from, each terminal five times. If all the terminals contained within the luminaire are not of the same design, one terminal of each design is subjected to the test.*

For the first four connections, new conductors are used each time. For the fifth connection, the same conductor is used as for the fourth connection and it is clamped at the same place. For each connection, the conductors are pushed into the terminals as far as the stop.

If the terminal is stated by the manufacturer to be suitable for stranded conductors (see 17.2.10), an additional test is then made with two rigid stranded copper conductors, the first having the largest cross-sectional area specified in 17.5.1, and the second having the smallest cross-sectional area. These conductors are subjected to only one connection and disconnection.

After the final connection, each conductor is subjected to a pull test according to Table 33.

17.5.2.3 *Pin or tab and receptacle type connections are also subjected to a pull test according to Table 33.*

Table 33 – Conductor pull force

Maximum rated current of terminals A	Pull N	
	Spring type and welded connections	Pin or tab and receptacle type
6	20	8
10	30	15
16	30	15

NOTE If the component rating is less than the terminal capacity, the component rating is used.

The pull is applied without jerks, for 1 min, in the direction opposite to that used for the application or insertion of the conductor or lead assembly.

During the test, the conductor or lead assembly shall not move out from the terminal and neither the terminal nor the conductor or lead assembly shall undergo any alteration impairing its future use.

17.5.3 Electrical tests

17.5.3.1 General

Terminals and connections shall have adequate electrical performance.

Compliance is checked by the tests of 17.5.3.2 and 17.5.3.3.

17.5.3.2 Contact resistance test

17.5.3.2.1 *The electrical performance of terminals (or connections) is checked on a set of ten terminals. If all the terminals contained within the luminaire are not of the same design, one set of ten terminals of each design is subjected to the test.*

17.5.3.2.2 *For spring-type terminals, the test according to 17.5.3.2.4 is made with ten solid copper non-insulated conductors.*

Five conductors having the largest cross-sectional areas specified in 17.5 are connected as in normal use, each to one terminal.

Five conductors having the smallest cross-sectional areas specified in 17.5 are connected as in normal use, each to one of the five remaining terminals.

17.5.3.2.3 *In the case of pin or tab and receptacle type terminals, the test according to 17.5.3.2.4 is made with lead assemblies.*

17.5.3.2.4 *Each terminal with its conductor is loaded with the test current (AC or DC) and, after 1 h, the voltage drop across the terminal, still at the test current is measured. The measuring points are located as close as possible to the contact point across which the voltage drop is being measured.*

The measured voltage drop shall not exceed 15 mV.

The total voltage drop of two inseparable joints, when measured together, shall not exceed twice the value given in this Subclause 17.5.3.2.4.

17.5.3.3 Heating tests

17.5.3.3.1 *The thermal performance of terminals (or connections) is checked on the terminals which have been subjected to the test of 17.5.3.2.*

17.5.3.3.2 *After having cooled down to the ambient temperature, each conductor is replaced by a new solid copper non-insulated conductor having the largest cross-sectional area specified in 17.5 and each lead assembly is replaced by a new appropriate lead assembly which is then connected to, and withdrawn from, the terminal or the relevant part of the connection five times.*

The conductors are then replaced by new non-insulated conductors or new lead assembly.

17.5.3.3.3 *Each terminal with its conductor is loaded with the test current (AC or DC) for a time just sufficient for the voltage drop to be measured. For these measurements and the measurements of 17.5.3.3.5, the requirements of 17.5.3.2 apply.*

17.5.3.3.4 Terminals (or connections) with a rated current up to and including 6 A are then subjected to an ageing test, without current, of 25 cycles duration, each cycle comprising 30 min at a temperature of $T \pm 5 \text{ }^\circ\text{C}$ or $100 \text{ }^\circ\text{C} \pm 5 \text{ }^\circ\text{C}$, whichever is the higher, followed by a cooling down period to a temperature between $15 \text{ }^\circ\text{C}$ and $30 \text{ }^\circ\text{C}$. Terminals (or connections) with a rated current exceeding 6 A are subjected to an ageing test of 100 such cycles.

The temperature T is the marked maximum rated temperature for T -marked components, such as lampholders.

17.5.3.3.5 The voltage drop is again measured on each terminal:

- a) after the 10th and 25th cycles for terminals with a rated current up to and including 6 A;
- b) after the 50th and 100th cycles for terminals with a rated current greater than 6 A.

If, for all terminals, the voltage drop, in both cases, does not exceed by more than 50 % the voltage drop measurements on the same terminal tested under 17.5.3.3.3, or if the increase in voltage drop is less than 2 mV, the terminals comply with the requirement.

If the voltage drop of any of the terminals exceeds 22,5 mV, the terminals are rejected.

If, for one of the terminals, the voltage drop measured under a) or b) exceeds by more than 50 %, with a minimum of 2 mV, the voltage drop measured on the same terminal under 17.5.3.3.3 but does not exceed 22,5 mV, the ten terminals are subjected to a new ageing test, according to current rating, of 25 cycles or 100 cycles duration without current.

After the 10th and 25th or 50th and 100th cycles (according to current rating), the voltage drops are again measured. For any terminal, the voltage drop shall not exceed 22,5 mV.

The total voltage drop of two inseparable joints, when measured together, shall not exceed twice the value given in this Subclause 17.5.3.3.5.

17.5.3.3.6 If a terminal is so designed that the conductor is tightened against a surface of insulating material, this surface shall not become deformed during these heating tests.

Compliance is checked by inspection.

Annex A (normative)

Test to establish whether a conductive part can cause an electric shock

A.1 General

In order to determine whether a conductive part is a hazardous live part which can cause an electric shock, the device under test (DUT) is operated at rated voltage and nominal supply frequency. A conductive part is not a hazardous live part if the requirements of Clause A.2 or Clause A.3 are met.

NOTE The purpose of Annex A is to establish if a conductive part can cause an electric shock, if touched. It does not indicate the kind and level of insulation used.

For the tests according to Clause A.2 and Clause A.3:

- one pole of the supply of the DUT shall be at earth potential;
- the test is done with both supply voltage polarities;
- the measurements are made:
 - between the part concerned and any accessible conductive part;
 - between the part concerned and earth.

A.2 Touch voltage limits

The voltage is measured by using a measuring circuit consisting of a non-inductive resistance of 50 k Ω .

The voltage shall not exceed

- for alternating current: 35 V (peak);
- for direct current: 60 V (ripple free);
- for interrupted direct current ($10 \text{ Hz} \leq f \leq 200 \text{ Hz}$): 25 V (peak);
- for interrupted direct current outside the range specified above: 70 V (peak).

A.3 Touch current limits

Where the voltage measured according to Clause A.2 exceeds the limit value, the touch current shall not exceed:

- for alternating current: 0,7 mA (peak);
- for direct current: 2,0 mA;
- For interrupted direct current ($10 \text{ Hz} \leq f \leq 200 \text{ Hz}$): 0,41 mA (peak);
- for interrupted direct current outside the range specified above: 0,7 mA (peak).

A.4 Compliance

Compliance is checked by using the measuring network from Figure G.2.

Annex B (normative)

Test lamps

B.1 General

For the tests of Clause 14, it is convenient to keep a stock of lamp types commonly required. These are selected from normal production lamps for characteristics as close as possible to the objective characteristics listed in the appropriate standards. The selected lamps are aged (at least 24 h for filament lamps and at least 100 h for tubular fluorescent and other discharge lamps, with occasional off periods), and a further check is made that their characteristics are still satisfactory and stable. Lamps shall not be retained as test lamps for longer than about three-quarters of their typical operating period in normal service. Lamps are inspected before each test for any damage or signs of approaching unserviceability. Discharge lamps shall be checked regularly to ensure that there has been no appreciable shift in electrical characteristics which would influence the temperatures in luminaires. If a lamp can be inserted in a circuit in more than one position (e. g. a fluorescent lamp) marks shall be made to assist consistent insertion. Great care shall be taken in handling test lamps; in particular, sodium vapour, mercury vapour and metal halide discharge lamps and amalgam fluorescent lamps shall not be moved while still hot. A lamp selected for a particular test shall be of a rating and type for which the luminaire is claimed to be suitable. If a choice of lamp shape, construction or finish is indicated by the manufacturer, the thermally most onerous shall be taken. Otherwise, the most common type shall be used.

The requirements according to Clause B.2 to Clause B.5 refer to the selection of lamps as test lamps, and to lamp selection for a particular test of a luminaire.

B.2 Filament lamps within the scope of IEC 60432-1 and IEC 60432-2

B.2.1 Principal modes of heat transfer and lamps used for testing

B.2.1.1 General

In seeking to test the luminaire with lamps which develop the most onerous conditions within it, consideration is given to two principal modes of heat transfer, radiation and conduction.

B.2.1.2 Radiation

The materials of the luminaire are heated by radiation from the lamp filament, supplemented, for the area immediately around and especially above the lamp, by convected heat from the bulb surface. In general, for testing such conditions, clear lamps are used. The filament shapes used in most HV lamps provide a slightly irregular radiation pattern but are unlikely to have highly directional properties. There is more variation in lamps designed for 100 V to 130 V, as lamps with transverse or axial filaments can produce different heating patterns which can be important in certain designs. Where reflector lamps are involved, note is taken of clear areas in the neck region. If it is intended to use lamps with heat transmitting reflectors, such lamps are used for tests. Light centre length also plays a role.

B.2.1.3 Conduction

The lampholder and associated wiring receive heat by conduction from the lamp cap and if the luminaire can operate with the lamp in the cap-up position, by convection transfer from the outer surface of the lamp.

B.2.2 Filament test lamps

B.2.2.1 General

Testing of the conditions according to B.2.1.3 and endurance testing require heat test source lamps (HTS lamps) prepared and used as specified in B.2.2.2 and B.2.2.3.

B.2.2.2 Preparation

Readily available lamps are used. Each lamp is uniquely identified and its cap temperature rise (Δt_S) shall be determined by the IEC 60360 method.

These values shall be compared to the values specified in IEC 60432-1:1999, Table 2 and IEC 60432-1:1999/AMD1:2005, Table 2 and IEC 60432-2:1999, Table 1 and IEC 60432-2:1999/AMD1:2005, Table 1, respectively, and the difference is noted ($\Delta(\Delta t_S)$).

Where IEC 60432-1 and IEC 60432-2 do not specify a temperature, then the manufacturer's data should be used, or manufacturers should be requested to supply test lamps.

B.2.2.3 Use

A known test lamp is used in the normal way for thermal testing, and its cap temperature noted. This figure is corrected by $\Delta(\Delta t_S)$ to obtain the final test figure. This is compared with standard limits in Table 21.

The following guidelines will help in the selection of suitable lamps.

Compared with clear or frosted lamps, higher cap temperatures are principally to be found on lamps which have:

- a white coated or dark coloured bulb;
- a smaller bulb;
- a shorter light centre length

Small differences from the specified Δt_S of IEC 60432-1:1999, Table 2 and IEC 60432-1:1999/AMD1:2005, Table 2 shall be corrected for the adjustment of the HTS lamps by the test voltage, but such adjustment shall not cause the power to exceed 105 % of the rated power (corresponding to 103,2 % voltage).

Additionally, for the thermal test by conduction only, the outer surface of a lamp may be hand printed with suitable high temperature paint, commencing in the area of the cap and, if necessary, extending over all the bulb surface.

For reflector and bowl mirror lamps, only the test voltage shall be used for adjustment of the temperature.

For endurance testing, HTS lamps which have been modified to give increased cap temperature are not used.

If the luminaire is provided with a marking for special lamps, or if it is obvious that special lamps are to be used in the luminaire, the tests are made with such special lamps.

Lamps are chosen in accordance with the maximum power for which the luminaire is marked. In case of doubt, for luminaires marked with a maximum 60 W, E27 or B22 cap, tests shall also be made with a 40 W round bulb lamp.

The voltage rating of the test lamps shall be typical of the voltage rating in the market for which the luminaire is intended. If the luminaire is intended for two or more different groups of voltage supply, for example for 200 V to 250 V and for 100 V to 130 V, then the testing shall at least be carried out with lamps in the low voltage range (i. e. with the higher current), but taking into account the comments above.

When choosing the range of lamps for testing, the requirement of 6.3.8 should be taken into account.

If a lamp is operated by a transformer or similar device within or external to the luminaire, the rating of the test lamp shall correspond to the marking on the luminaire, transformer or similar instructions.

B.3 Halogen lamps within the scope of IEC 60432-3

The test is carried out with the lamps provided by the luminaire manufacturer.

Attention should be given to special features of these lamps (e.g. beam angle, cool-beam versions).

B.4 Tubular fluorescent and other discharge lamps

When a lamp is operated under reference conditions (according to the relevant IEC lamp standard), the lamp voltage, current and power shall be as close as possible to the lamp rated values, and shall be within 2,5 % of these values.

If a reference ballast is not available, lamps are selected using a production ballast which, at the calibration current, has an impedance within ± 1 % of that of the reference ballast.

Self-ballasted lamps are considered as fluorescent or other discharge lamps for the purpose of Clause 14. If the luminaire is for use with filament lamps and self-ballasted lamps or other discharge lamps incorporating series filaments, it should be tested with the most onerous lamp (which in general will be with filament lamps).

If the luminaire is for use with a combination of lamp types (e.g. filament lamp plus a discharge lamp), it should be tested with the thermally most onerous type.

If the luminaire is for use with either filament or discharge lamps, it should be tested with the more onerous (or, if not known, with each in turn).

It is usually found that translucent materials attain a higher temperature with a discharge lamp or a discharge lamp incorporating a series filament than with a filament lamp, for a given lamp power.

If the luminaire is designed for a lamp type for which specifications have not yet been established, a test lamp should be selected after consultation with the lamp manufacturer.

B.5 LED modules within the scope of IEC 62031

The test is carried out with the LED modules provided by the luminaire manufacturer.

Annex C (normative)

Abnormal circuit conditions

The following is a list of abnormal circuit conditions which are applicable to a tubular fluorescent or other discharge lamp luminaire and from which the thermally most onerous condition shall be taken (see 14.5). If the luminaire contains more than one lamp, the abnormal conditions shall be applied only to the one lamp, which leads to the most adverse results. The abnormal condition shall be set up before the test is started. Conditions d) and e) refer only to lamps with two preheated electrodes (e.g. fluorescent lamps). The descriptions include instructions for test arrangements. Conveniently, the abnormal circuit condition is produced or simulated by remote switching so that it is not necessary to disturb a luminaire which has just completed the test of normal operation.

a) Short-circuit of starter contacts

This condition applies to starters with moving contacts, including starters incorporated in lamps.

b) Lamp rectification

1) Luminaires for fluorescent lamps (Figure C.1 and Figure C.2).

This is a fault condition which can occur after extended use in luminaires employing starterless ballasts with capacitive reactance control. When testing luminaires for the rectifying effect, the circuit shown in Figure C.1 shall be used. The lamp is connected to the midpoint of the appropriate equivalent resistors. The rectifier polarity is chosen so as to give the most unfavourable operating conditions. If necessary, the lamp is started using a suitable starting device.

The rectifier characteristics shall be:

- peak inverse voltage ≥ 800 V;
- reverse leakage current ≤ 10 μ A;
- forward current > 3 times nominal lamp running current;
- transition time ≤ 50 μ s.

Luminaires for tubular fluorescent lamps having Fa6 caps however, shall be tested as follows.

Initially, the lamp is operated under normal conditions with a short-circuited rectifier in series with the lamp. Then the bridging of the rectifier is opened. The rectifier shall be inserted in both polarities. The test is finished if the lamp extinguishes. If not, the following test is carried out.

The lamp is operated as shown in Figure C.2. The rectifier polarity shall be chosen so as to give the most unfavourable operating conditions. If necessary, the lamp is started using a suitable starting device.

2) Luminaires for some metal halide lamps and some high-pressure sodium vapour lamps which, according to the lamp safety standard IEC 62035, can lead to controlgear, transformer or starting device overloading (Figure C.3).

The lamp in the luminaire is replaced by the test circuit as shown in Figure C.3. The test is commenced with the test circuit, luminaire and controlgear stabilized at the ambient temperature of the draught-proof enclosure. By varying the resistance R , the lamp current is adjusted to a value equal to twice the normal lamp current. No further adjustment of the resistance R is made.

If steady conditions are reached before the temperature limits of 14.5 are exceeded, and for thermally protected controlgear the protection device has not operated, then the resistance R shall be adjusted to increase the current in suitable steps, for example 10 % increments. Care is taken to achieve steady conditions as far as possible at each step. In all cases, the current shall not be adjusted above a value equal to three times the normal lamp current.

NOTE For circuits protected by a self-resetting protection device, it is possible that a number of on/off cycles will have to occur before maximum temperatures have been reached.

Luminaires incorporating the following specific categories of metal halide and high-pressure sodium lamps are exempt from the above rectification test requirements:

- high-pressure sodium lamps with rated power of 1 000 W and above;
- high-pressure sodium lamps designed as direct replacements for mercury lamps;
- high-pressure sodium and metal halide lamps identified by IEC 62035 as not being liable to end of life rectification;
- other high-pressure sodium and metal halide lamps for which no end of life rectification risk has been identified by the lamp manufacturer. (This can limit suitability of the luminaire to specific lamp makers only).

c) Lamps removed and not replaced.

d) One electrode of lamp open-circuited.

The conditions may be produced by switching. (Alternatively, a test lamp may be suitably modified).

The electrode selected shall be that which more adversely affects the results.

e) The lamp will not start, but both electrodes are intact. For this condition, a non-serviceable or modified test lamp may be used.

f) Blockage of the motor(s) contained in the luminaire.

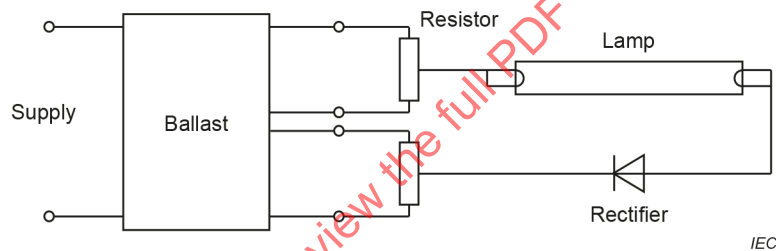

Figure C.1 – Circuit for testing rectifying effect (some capacitive starterless ballasts only)

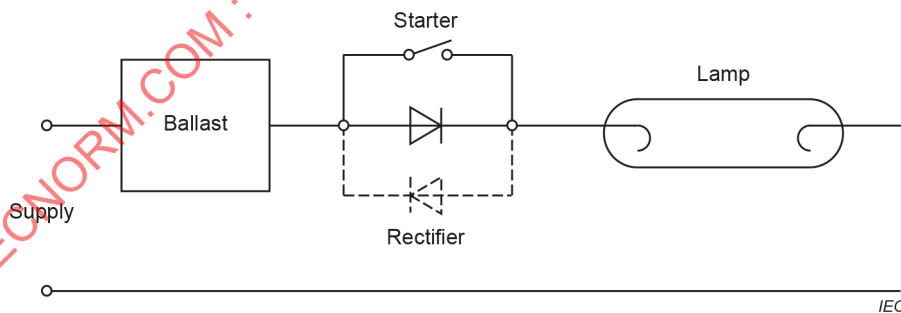
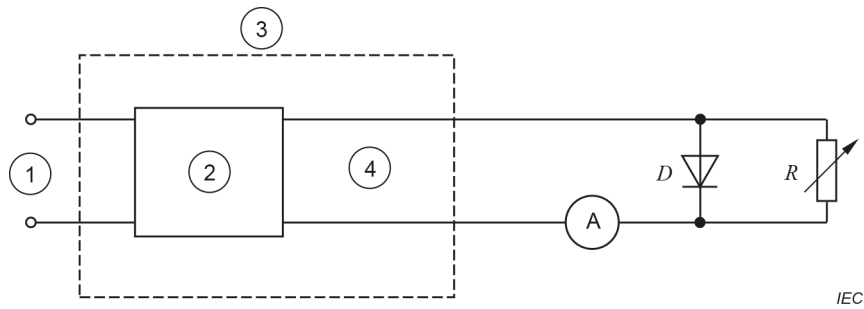

Figure C.2 – Circuit for testing rectifying effect (ballasts for single pin lamps)



IEC

Key

- 1 supply
- 2 controlgear, transformer, starting device
- 3 luminaire
- 4 lamp connections
- D* 100 A, 600 V
- R* 0 Ω to 200 Ω (power rating of the resistor to be at least half the lamp power)

Figure C.3 – Circuit for testing rectifying effect of some high-pressure sodium and some metal halide lamps

IECNORM.COM : Click to view the full PDF of IEC 60598-1:2024

Annex D (normative)

Thermal testing

D.1 Draught-proof enclosure

The following recommendations refer to the construction and use of a suitable draught-proof enclosure for luminaires, as required for the tests of normal and abnormal operation. Alternative constructions for draught-proof test areas are suitable if the test area is equipped with similar or larger physical dimensions and if the draught is less than or equal to 0,25 m/s.

NOTE The value 0,25 m/s has been taken from IEC 60068-2-2:2007, derived from 0,2 m/s taking into account possible measurement tolerance.

The draught-proof enclosure is rectangular, with a double skin on top and on at least three sides, and with a solid base. The double skins are of perforated metal, spaced approximately 150 mm apart, with regular perforations of 1 mm to 2 mm diameter, occupying about 40 % of the whole area of each skin.

The internal surfaces are painted with a matt paint. The three principal internal dimensions are each at least 900 mm. There shall be a clearance of at least 200 mm between the internal surfaces and any part of the largest luminaire for which the enclosure is designed.

If it is required to test two or more luminaires in a large enclosure, care should be taken that radiation from one luminaire cannot affect any other.

There is a clearance of at least 300 mm above the top of the enclosure and around the perforated sides. The enclosure is at a location protected as far as possible from draughts and sudden changes in air temperature; it is also protected from sources of radiant heat.

A luminaire under test is positioned as far away as possible from the six internal surfaces of the enclosure. The luminaire is mounted (subject to the requirements of 14.4.2 and 14.5.2) as under service conditions.

D.2 Mounting surface

A luminaire for direct fixing to a ceiling or wall should be fixed to a mounting surface comprising a wood or wood-fibre board. A non-combustible insulating material is used if the luminaire is not suitable for direct mounting on normally flammable surfaces. The board is 15 mm to 20 mm thick, and extends not less than 100 mm (but preferably not more than 200 mm) beyond the normal projection of the smoothed outline of the luminaire. There is a clearance of at least 100 mm between the board and the internal surfaces of the enclosure. The board is painted black with a matt non-metallic paint.

A luminaire for corner-fixing is fixed in a corner comprising two boards, each complying with the preceding requirements.

A third board is required if the luminaire is to be fixed in a vertical corner immediately below a simulated ceiling.

For luminaires classified as not suitable for direct mounting on normally flammable surfaces, no temperatures are measured for the mounting surface.

A track-mounted luminaire is connected to a track system appropriate to the luminaire. The track is mounted as in normal use, according to the manufacturer's installation instructions. The luminaire is connected to the track in the most onerous thermal position of normal use permitted by the mounting instructions or marking. The luminaire is operated under the conditions specified in 14.4.2 and 14.5.2.

D.3 Alternative test procedure for adjustment of measured temperatures for luminaire t_a rating(s)

D.3.1 General

The following test method can be used as an alternative to the reference test of 14.4.2 c) for luminaires:

- without temperature sensing controls, and
- where the rated ambient temperature t_a as marked on the luminaire is higher than the temperature in the draught-proof enclosure, and
- where the light source has temperature-sensitive electrical (power) characteristics with a negative temperature coefficient (e.g. LED light source with constant current type – controlgear assembly).

D.3.2 Thermal test of normal operation for luminaires without temperature sensing controls and where the rated ambient temperature t_a as marked on the luminaire is higher than the ambient temperature in the draught-proof enclosure

The luminaire shall be tested under the conditions specified in 14.4.2 a) to l) and according to the following:

The ambient temperature within the draught-proof enclosure shall be within the range of 10 °C to 30 °C and should preferably be 25 °C. It shall not vary by more than ± 1 °C during measurements and during a preceding period long enough to affect the results. The difference between the temperature in the draught-proof enclosure and the rated t_a temperature shall be calculated. The calculated difference temperature shall be added to each measured temperature value.

Annex E (normative)

Determination of winding temperature rises by the increase-in-resistance method

Before commencing the test, arrangements are made whereby the ballast may be quickly connected by appropriate means of negligible resistance to a Wheatstone bridge, or other suitable measuring instrument, after the luminaire has been disconnected from the supply.

Reference to ballasts also applies to similar components such as transformers.

A chronometer with an easily-read second hand is essential.

The test procedure is as follows.

The luminaire remains unenergized for a period long enough to ensure that the complete luminaire, including the ballast windings, is thermally stable in a substantially constant ambient temperature (t_1), which shall not change by more than 3 °C during this period.

The resistance (R_1) of the cold ballast winding is measured and t_1 noted. The luminaire is operated until thermal stability has been achieved as indicated by a suitable temperature measuring device attached to the body of the ballast. The ambient air temperature (t_3) in the draught-proof enclosure is noted.

The luminaire is then disconnected from the supply, the time noted and the ballast connected immediately to the Wheatstone bridge. The resistance is measured as quickly as possible and the corresponding time noted.

Further resistance measurements, if necessary, are made at suitable intervals whilst the ballast is cooling, the times at which the measurements are made being recorded. These measurements enable a time/resistance curve to be plotted which is extrapolated back to the point corresponding to the instant of disconnection of the supply and the resistance R_2 of the hot winding is read.

Since the resistance of copper varies in direct proportion to the temperatures as measured from a reference point of –234,5 °C, the hot temperature t_2 may be calculated from the ratio of the hot resistance R_2 to the cold resistance R_1 by means of the equation:

$$\frac{R_2}{R_1} = \frac{t_2 + 234,5}{t_1 + 234,5}$$

The constant 234,5 relates to copper windings; for aluminium, this constant is 229. Hence, for windings of copper wire:

$$t_2 = \frac{R_2}{R_1} (t_1 + 234,5) - 234,5$$

The temperature rise is the difference between the calculated temperature t_2 and the ambient air temperature t_3 at the conclusion of the test, that is:

$$\text{temperature rise} = (t_2 - t_3) \text{ K}$$

Annex F (normative)

Test for resistance to stress corrosion of copper and copper alloys

F.1 Test cabinet

Closeable glass vessels shall be used for the test. These may be, for example desiccator vessels or simple glass troughs with ground rim and lid. The vessels' volume shall be at least 10 l. A certain ratio of test space to volume of test solution shall be maintained (20:1 to 10:1).

F.2 Test solution

The preparation of 1,0 l of solution is as follows.

Dissolve 107 g of ammonium chloride (reagent grade NH_4Cl) in about 0,75 l of distilled or fully demineralized water and add as much of 30 % sodium hydroxide solution (prepared from reagent NaOH and distilled or fully demineralized water) as is necessary to reach a pH value of 10 at 22 °C. For other temperatures, adjust this solution to the corresponding pH values specified in Table F.1.

Table F.1 – pH value of the test solution

Temperature °C	Test solution pH
22 ± 1	10,0 ± 0,1
25 ± 1	9,9 ± 0,1
27 ± 1	9,8 ± 0,1
30 ± 1	9,7 ± 0,1

After the pH adjustment, make up to 1,0 l with distilled or fully demineralized water.

This does not change the pH value any more.

Keep the temperature in any event constant to within ±1 °C during the pH adjustment, carry out the pH measurement using an instrument which permits an adjustment of the pH value to within ±0,02.

The test solution may be used over a prolonged period, but the pH value which represents a measure of the ammonia concentration in the vapour atmosphere shall be checked at least every three weeks and adjusted if necessary.

F.3 Test piece

The test is made on test pieces taken from the luminaires.

F.4 Test procedure

The surfaces of the test pieces shall be carefully cleaned, varnish being removed by acetone grease and finger prints by petroleum spirit or similar product.

The test cabinet containing the test solution shall be brought to a temperature of $(30\text{ °C} \pm 1\text{ °C})$. The test pieces, pre-heated to 30 °C shall be placed in the test cabinet as quickly as possible in such a way that the ammonia vapour can take effect unhindered. The test pieces shall be suspended so that they do not dip into the test solution nor touch each other. Supports or suspension devices shall be made of materials which are not susceptible to attack by ammonia vapour, for example glass or porcelain.

Testing shall be carried out at a constant temperature of $(30\text{ °C} \pm 1\text{ °C})$ to exclude visible condensed water formation caused by temperature fluctuations, which can severely distort the test results. The test period shall commence when the test cabinet is closed and shall last for 24 h. After this treatment, the test pieces shall be washed in running water; 24 h later, they shall show no cracks when inspected at an optical magnification of $8\times$.

In order not to influence the results of the test, the test pieces shall be handled with care.

IECNORM.COM : Click to view the full PDF of IEC 60598-1:2024

Annex G (normative)

Measurement of touch current and protective conductor current ⁵

G.1 General

The luminaire is tested at an ambient temperature of $25\text{ °C} \pm 5\text{ °C}$ and at rated supply voltage and frequency in the test circuit shown in Figure G.1.

G.2 Test conditions

The luminaire is operated with the lamp(s) of the type for which it is intended, such that, when stabilized at rated voltage, the lamp power and voltage of fluorescent and other discharge lamps are within $\pm 5\%$ of the rated values.

G.3 Test procedures

The luminaire shall be connected to the power supply with the wiring and any materials (e.g. insulating sleeves) supplied with the luminaire for the purpose. In general, connection shall be in accordance with the instructions provided with the luminaire or marked on it. Otherwise, wiring required to connect the luminaire under test to the supply and not supplied with it should be of a type representative of common practice. The protective conductor current is measured with the measuring network in Figure G.4 connected according to Figure G.1, between the PE conductor of the luminaire and the isolating transformer secondary neutral/earth pole. The measuring network for touch current is disconnected. If the luminaire is provided with functional earth terminal or functional earthing contact (separated from protective earth), this shall not be connected for the protective current measurement.

The test sequence shall be as detailed in Clause G.5 but "e" always open and no measurements shall be made on class II luminaires.

The voltage U_4 measured with a high resistance voltmeter (electronic or an oscilloscope) in RMS is divided by the resistance R and the value for the current is given in RMS.

G.4 Test measurements

For the measurements of the touch current, the circuit specified in Figure G.1, Figure G.2, and Figure G.3 are used.

The test sequence shall be as detailed in Clause G.5. The standard test finger (test probe B according to IEC 61032:1997, Figure 2) is used as the test probe and is applied to accessible metal parts, or accessible insulating parts wrapped in foil, $10\text{ cm} \times 20\text{ cm}$ in size, of the luminaire body.

The method of measurement described here is based on the assumption that the luminaire is used in a star TN or TT system, i.e. the luminaire is connected between line (L) and neutral (N). For other systems, IEC 60990 shall be used.

⁵ The tests and the requirements of Annex G are taken from IEC 60990. For full details, see IEC 60990.

In the case of multiphase connections, the same procedure occurs, but the measurements are made on one phase at the time. The same limits apply for each phase.

The measuring network of Figure G.3 is used for portable class I luminaires fitted with a plug connectable to an unearthed socket-outlet, while the measuring network of Figure G.2 is used in all other cases except when the protective conductor current is asked for.

The voltages U_2 and U_3 in the measuring networks of Figure G.2 and Figure G.3 are peak voltages and shall be measured after the connection of the measuring network disregarding the first readings which can be influenced by capacitances of the circuit.

If frequencies above 30 kHz are involved, the measurement of touch current shall include the measurement with regard to electric burn effects in addition to the measurement of Figure G.2. For the burn effects, the unweighted RMS value of the touch current is relevant. Unweighted touch current is calculated from the RMS voltage U_1 , measured across the 500 Ω resistor of Figure G.2.

The terminal A electrode (standard test finger) shall be applied to each accessible part in turn. For each application of the terminal A electrode, the terminal B electrode shall be applied to the earth of the measuring equipment, then applied to each of the other accessible parts in turn.

For measurement on class II luminaires, the protective conductor is ignored. For the purposes of this test, if the luminaire is provided with functional earth terminal or functional earthing contact, this shall be considered as an accessible part and tested consequently.

The test circuit of Figure G.1 shall employ an isolating transformer and the main protective earthing terminal of the EUT earthed. Any capacitive leakage current in the transformer shall then be taken into account. As an alternative to earthing the EUT, the test transformer secondary and the EUT shall be left floating (not earthed), in which case the capacitive leakage current in the test transformer is not taken into account.

Where a protective impedance device is incorporated, during the measurements, each one of the resistors and all other components (except Y1 and Y2 capacitors complying with the relevant requirements of IEC 60384-14), if any, are short-circuited one at a time.

Requirements for class III luminaires, tracks and wire systems are under consideration.

G.5 Test sequence

The touch current is measured as follows.

Table G.1 – Position of switches e, n and p for the measurements of the different classes of luminaires

Type of luminaire	Position of the switch (see Figure G.1)		
	e	n	p
a) Class II	-	Closed	1
	-	Closed	2
	-	Open	1
	-	Open	2
b) Class I, permanently connected ^a	Closed	Closed	1
	Closed	Closed	2
	Closed	Open	1
	Closed	Open	2
c) Class I, fitted with a plug connectable to an unearthed socket-outlet	Closed	Closed	1
	Closed	Closed	2
	Open	Closed	1
	Open	Closed	2
	Closed	Open	1
	Closed	Open	2
	Open	Open	1
	Open	Open	2

^a These measurements are relevant for class I luminaires containing class II insulated parts only.

In the case of portable, settable and adjustable luminaires incorporating a switch for use with fluorescent or other discharge lamps, the luminaire shall be switched off after the measurements. The luminaire is then switched on and before the lamp(s) restarts, the touch current is measured again as stated in Table G.1.

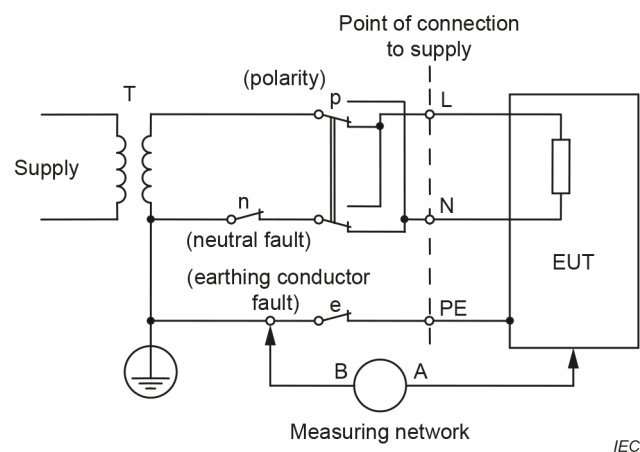

Figure G.1 – Test configuration: single-phase equipment on star TN or TT system

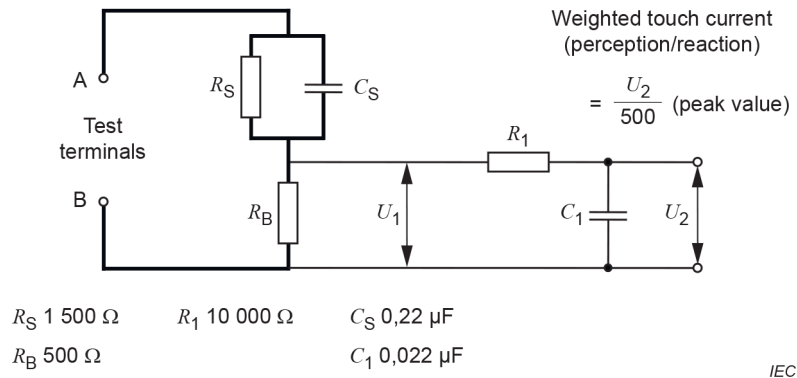

Figure G.2 – Measuring network, touch current weighted for perception or reaction

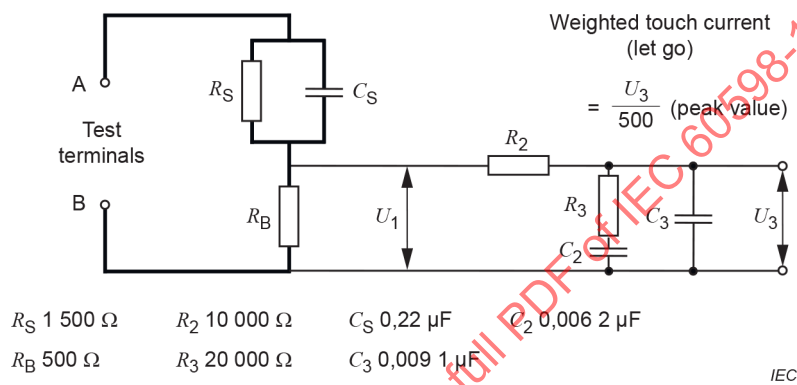

Figure G.3 – Measuring network, touch current weighted for let-go (for portable class I luminaires)

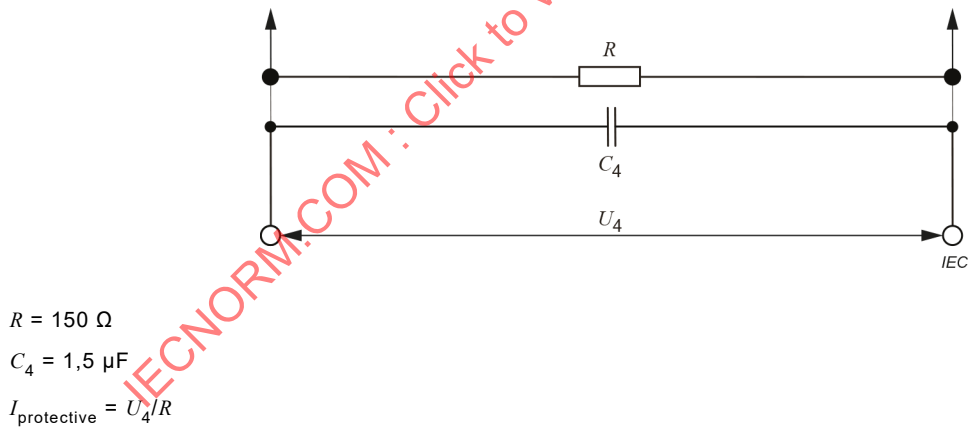

Figure G.4 – Measuring network, weighted for high frequency

Annex H (informative)

Explanation of IP numbers for degrees of protection

The type of protection covered by this system of classification is as follows. For full details, see IEC 60529.

- a) Protection of persons against contact with or approach to hazardous live parts and against contact with moving parts (other than smooth rotating shafts and the like) inside the enclosure and protection of the equipment against ingress of solid foreign bodies.
- b) Protection of the equipment inside the enclosure against harmful ingress of water.

The designation to indicate the degrees of protection consists of the characteristic letters IP followed by two numerals (the "characteristic numerals") indicating conformity with the conditions stated in Table H.1 and Table H.2 respectively. The first numeral indicates the degree of protection described under item a) above and the second numeral the degree of protection described under item b) above.

Table H.1 – Degrees of protection indicated by the first characteristic numeral

First characteristic numeral	Degree of protection	
	Short description	Brief details of objects which will be "excluded" from the enclosure
0	Non-protected	No special protection.
1	Protected against solid objects greater than 50 mm	A large surface of the body, such as a hand (but no protection against deliberate access). Solid objects exceeding 50 mm in diameter.
2	Protected against solid objects greater than 12 mm	Fingers or similar objects not exceeding 80 mm in length. Solid objects exceeding 12 mm in diameter.
3	Protected against solid objects greater than 2,5 mm	Tools, wires, etc., of diameter or thickness greater than 2,5 mm. Solid objects exceeding 2,5 mm in diameter.
4	Protected against solid objects greater than 1,0 mm	Wires or strips of thickness greater than 1,0 mm. Solid objects exceeding 1,0 mm in diameter.
5	Dust-protected	Ingress of dust is not totally prevented but dust does not enter in sufficient quantity to interfere with satisfactory operation of the equipment.
6	Dust-tight	No ingress of dust.

Table H.2 – Degrees of protection indicated by the second characteristic numeral

Second characteristic numeral	Degree of protection	
	Short description	Details of the type of protection provided by the enclosure
0	Non-protected	No special protection.
1	Protected against dripping water	Dripping water (vertically falling drops) shall have no harmful effect.
2	Protected against dripping water when tilted up to 15°	Vertically dripping water shall have no harmful effect when the enclosure is tilted at any angle up to 15° from its normal position.
3	Protected against spraying water	Water falling as a spray at an angle up to 60° from the vertical shall have no harmful effect.
4	Protected against splashing water	Water splashed against the enclosure from any direction shall have no harmful effect.
5	Protected against water jets	Water projected by a nozzle against the enclosure from any direction shall have no harmful effect.
6	Protected against heavy seas	Water from heavy seas or water projected in powerful jets shall not enter the enclosure in harmful quantities.
7	Protected against the effects of immersion	Ingress of water in a harmful quantity shall not be possible when the enclosure is immersed in water under defined conditions of pressure and time.
8	Protected against submersion	The equipment is suitable for continuous submersion in water under conditions which shall be specified by the manufacturer. NOTE Normally, this will mean that the equipment is hermetically sealed. However, with certain types of equipment, it can mean that water can enter but only in such a manner that it produces no harmful effects.
9 (80 °C)	Protected against high pressure and temperature water jets	Water projected at high pressure and high temperature against the enclosure from any direction shall not have harmful effects.
9 (15 °C)	Protected against high pressure and cold water jets	Water projected at high pressure against the enclosure from any direction shall not have harmful effects.
Specialist cleaning techniques are not covered by IP ratings. Manufacturers are recommended to give appropriate information regarding cleaning techniques, where necessary. This is in line with the recommendations contained within IEC 60529 for specialist cleaning techniques.		

In the case of degrees of protection against ingress of water indicated by the second characteristic numeral, refer to IEC 60529.

Annex I (informative)

Temperature measurements

I.1 Temperature measurements of the luminaire

The following recommendations refer to methods of making temperature measurements on luminaires in a draught-proof enclosure in accordance with 14.4. These methods of measurement have evolved as being particularly suitable for luminaires; alternative methods may be used if it is established that they are of at least equal precision and accuracy.

Temperatures of solid materials are usually measured by means of thermocouples. The output voltage is read by a high-impedance device such as a potentiometer. With a direct-reading instrument, it is important to check that its input impedance is suited to the impedance of the thermocouple. Temperature-indicators of the chemical type are at present suitable only for rough checks of measurement.

The thermocouple wires should be of low thermal conductivity. A suitable thermocouple consists of 80/20 nickel-chromium paired with 40/60 nickel-copper (or with 40/60 nickel-aluminium). Each of the two wires (usually of strip form, or circular in section) is fine enough to pass through a 0,3 mm diameter hole. All the end-portions of the wires liable to be exposed to radiation have a high-reflectance metal finish. The insulation of each wire is of suitable temperature and voltage rating; it is also thin but robust.

Thermocouples are attached to the measuring point with minimum disturbance of thermal conditions and with low-resistance thermal contact. If a particular point on a part is not specified, the point of highest temperature should be found by preliminary exploration (for this purpose, a thermocouple may be mounted in a holder made of material of low thermal conductance; instruments using thermistors are also convenient). It is important to explore materials such as glass, since the temperature may vary rapidly with position. Thermocouples mounted within or near a luminaire should have minimum exposure to conducted or radiant heat. Care should be taken to avoid voltages from current-carrying parts.

The following methods have been found useful for attaching thermocouple junctions at measuring points.

- a) *Mechanical clamping, for example under a fixing device (clamping under current-carrying parts should be avoided).*
- b) *Soldering to a metal surface (with a minimum amount of solder).*
- c) *By an adhesive (minimum amount required). The adhesive should not separate the thermocouple from the measuring point. An adhesive used with a translucent material should be as translucent as possible. A suitable adhesive for use with glass is formed of one part of sodium silicate to two parts of calcium sulphate, with water medium.*

On non-metal parts, the last 20 mm of the thermocouple are attached to the surface to offset the flow of heat from the measuring point.

- d) *Cables. The insulation is slit and the thermocouple inserted (without touching a conductor); the insulation is then bound up.*
- e) *Mounting surfaces (see Annex D). A thermocouple is attached to a copper disc (approximately 15 mm in diameter, 1 mm thick, and with a matt black finish), sunk level with the surface at the hottest point.*

The average ambient temperature in the draught-proof enclosure is taken to be the air temperature at a position near one of the perforated walls on a level with the centre of the luminaire. The temperature is usually measured by a thermocouple soldered to a metal mass of approximately 30 g shielded against radiation by a double-walled cylinder of polished metal open at the top and bottom.

The average temperature throughout a winding is measured by the increase-in-resistance method. The procedure to be followed is described in Annex E.

It is found that errors are often made in the estimated calculation. An independent rough check should be made by measuring the case temperature of the component and adding a winding-to-case differential appropriate to the construction.

It is important that all temperature measuring instruments should be checked regularly. It is also recommended that measuring authorities should interchange luminaires to improve consistency in the measurement of different materials at different temperature levels.

I.2 Temperature measurement of the insulation parts of lampholders

Thermocouples should be applied on the following measuring points, as shown in Figure I.1:

- a) *lampholder rim (not on metal or ceramic lampholders);*
- b) *at the point of contact between the lamp cap and the lampholder (if made of insulation material other than ceramic);*

It is the intention that measurement takes place on the lampholder, and should be as near as possible to the point of contact between the lamp cap and the lampholder without touching the lamp cap;

- c) *at bifurcation of the cable with a maximum of 10 mm from the lampholder terminals (if any – this measuring point being important as the wiring can touch it).*

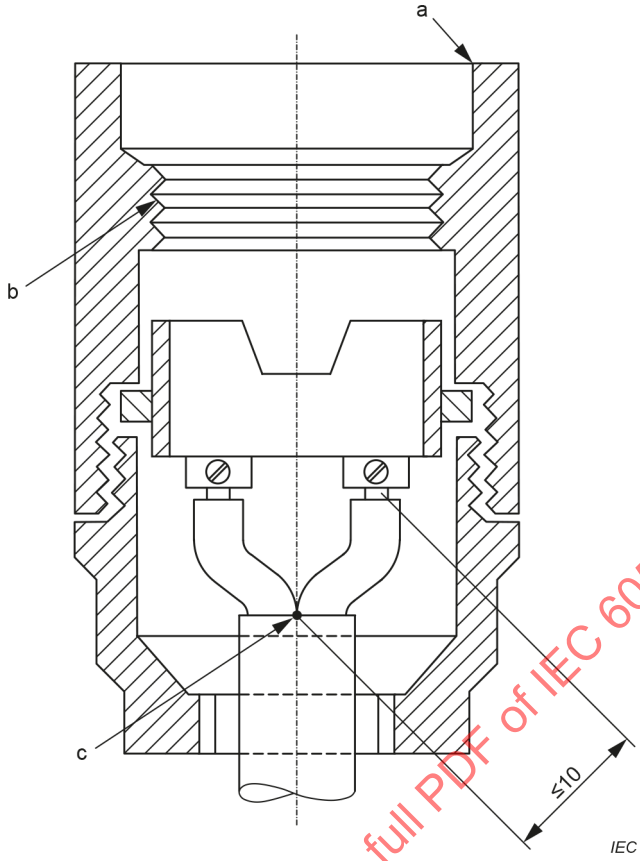

Figure I.1 – Placing of thermocouples on a typical lampholder

IECNORM.COM : Click to view the full PDF of IEC 60598-1:2024

Annex J (informative)

Guidelines for good practice in luminaire design

J.1 General

These guidelines for good practice are intended to advise luminaire manufacturers on aspects of luminaire design that, due to their nature, are not currently controlled by standardized test and assessment regimes. Annex J provides information covering aspects such as material selection, plastic material degradation through life, the effects of corrosive elements and appropriate protection, thermal considerations in optical design, recommendations related to lamps' end of life phenomenon and resistance against vibration.

These guidelines apply to luminaires for indoor and outdoor use and advise on generally accepted constructions, but are not exhaustive. These guidelines should therefore never be interpreted as a requirement since other solutions can be equally effective or even better in certain specific applications.

A classification of external influences is given in IEC 60364-5-51.

J.2 Plastics in luminaires

In luminaire construction, plastic components have become important and proven functional elements. This applies to internal parts and wiring, and to components such as translucent covers, shields and parts for structural support.

The applications relative to the "normal" usage of luminaires determine the normal running life (ageing) of these plastic parts.

Excessive hard usage and damaging influences diminish the resistance to ageing. See Table J.1.

Table J.1 – Damaging influences

Damaging influence	Cause	Effects ^a
High operating temperature	Operating voltage too high Ambient temperature too high Inappropriate mounting	Deformation Embrittlement Discoloration
UV radiation	Mercury-dosed high-pressure lamps with excessive UV component Germicidal lamps	Yellowing Embrittlement
Aggressive substance	Softeners (plasticizers) Incorrect cleaning (with disinfecting means)	Cracking Reduced strength Outer surface damage

^a All causes can relate to all effects.

Special attention should be given to:

- continuous service temperature;
- UV and visible radiation;
- static and dynamic mechanical impact;
- oxidizing atmospheres.

Some combinations of these influences have particular importance and can make the material unsuitable for the intended application. For example, the combination of UV radiation and heat can produce a green substance from PVC cable insulation, indicating the degradation of the insulation. The properties published with respect to particular materials of given generic names can differ depending on the fillers or inhibitors used, the manufacturing procedure and the design.

J.3 Rust resistance

Luminaires for use in normal indoor atmospheres may be made from a wide variety of materials.

Sheet metal components of the luminaire should be suitably pre-treated and surface finished, for example stove-enamelled.

Unpainted aluminium reflectors and louvres should be of an aluminium alloy with an anodic coating.

Auxiliary components of luminaires such as clips, hinges, when electroplated with suitable materials, will give satisfactory service in normal indoor atmospheres. Suitable coatings are zinc, nickel/chromium and tin.

NOTE The electrical safety of luminaires for indoor use under humid conditions is checked by the tests of Clause 11.

J.4 Corrosion resistance

Luminaires for use outdoors, or indoors in atmospheres of high humidity should have adequate resistance to corrosion. Although it is assumed that these luminaires will not be required to operate in conditions where chemical vapours are present, it should be remembered that all atmospheres contain a small proportion of corrosive gases such as sulphur dioxide and that in the presence of moisture, these can cause severe corrosion over a long period of time.

In the assessment of the resistance to corrosion of a luminaire, it should be borne in mind that the interior of a closed luminaire (even if it has one or more drain-holes) is much less subject to corrosion than the exterior.

The following metals or combinations are known to provide adequate corrosion resistance:

- a) copper and bronze, or brass containing not less than 80 % copper;
- b) stainless steel;
- c) aluminium (sheet, extruded or cast) and die-cast zinc, known to be resistant to atmospheric corrosion;
- d) cast iron or malleable iron at least 3,2 mm thick, coated with a minimum of 0,05 mm zinc on the outside surfaces and a visible coating of such material on the inside surface;
- e) sheet steel, zinc-coated, average coating thickness of 0,02 mm;
- f) polymeric materials, see Clause J.1.

Metal components in contact with one another should be made from metals which lie close to each other in the galvanic series to avoid electrolytic corrosion. For example, brass or other copper alloys should not be used in contact with aluminium or aluminium alloys; contact between either of these groups of materials and stainless steel is much more acceptable.

Plastic materials used outdoors should usually be chosen from those whose characteristics do not change significantly during long periods of service, for example acrylics.

Cellulose materials are in general unsatisfactory for conditions of high humidity, either indoors or outdoors, and others including polystyrene, while suitable for use indoors, are liable to severe deterioration if used outdoors owing to the combination of moisture and solar radiation.

Where the construction of plastic luminaires intended for high humidity conditions (indoors or outdoors) includes cemented joints, it is essential that the cement used be able to withstand continuous exposure to moisture for long periods without deterioration.

NOTE The electrical safety of luminaires for outdoor use under humid conditions is checked by the tests of Clause 11.

J.5 Chemically corrosive atmospheres

Luminaires to be used in atmospheres where chemically corrosive vapour or gases can be present in considerable concentration, and especially where condensation appears, require that the precautions given above for outdoor luminaires be observed and that the following additional precautions be taken.

- a) In general, luminaires whose bodies are made by casting a corrosion-resistant metal will give better service than sheet metal luminaires.
- b) Where metals are used, they should, as far as possible, be chosen for resistance to the particular corrosive substance present, as most metals are subject to attack by some corrosive substance. Die-cast aluminium will be satisfactory for most applications.
- c) Similarly, the paints or other protective systems used should be chosen with regard to particular corrosive substances or groups of corrosive substances. For example, it is possible that paints which are highly acid-resistant will not be able to withstand attack by some alkalis.
- d) Plastics such as acrylics, PVC and polystyrene are very resistant to attack by most inorganic acids and alkalis. They are, however, liable to attack by a number of organic liquids and vapours and as the effect depends on both the type of plastic and the particular chemical, materials should be chosen to suit the particular conditions.
- e) Vitreous enamel finishes are resistant to many chemicals, but it is essential that the enamel coating be free from broken areas or cracks if satisfactory service is to be obtained in highly corrosive atmospheres.

J.6 Reflector design

The materials used in the reflection of light also reflect the infra-red spectrum in a very similar manner. Thus an optically efficient reflector will also reflect most IR radiation from the luminaire thus reducing overheating effects.

It is very important that hot spots are not concentrated on parts of the luminaire and lamp where they can affect performance or reduce the durability of materials. In particular, it is recommended that reflected light (and IR) is not focused back onto the lamp wall, lamp filament or arc tube. This will affect the life of the lamp and in extreme cases, can cause failure of the lamp envelope or arc tube.

The maximum operating temperatures given in the lamp standards should not be exceeded (see Clause 2).

J.7 Components in different kinds of luminaires

In component standards, the creepage distances and clearances are normally related to certain conditions such as pollution degree 2 and overvoltage category I, which should be kept in mind for the selection of components in luminaires. Other parameters, for example fire resistance or tracking resistance, can also influence the selection of components in luminaires. This also means that the components in question can be used in the majority of the luminaires where the corresponding conditions prevail. In some luminaires, for example some road and street lighting luminaires, emergency lighting luminaires, other more stringent conditions apply. This can imply that the "normal" components cannot be used without complying with these more stringent conditions. The consequence of this can be that the luminaire manufacturer would have to work with components complying with different conditions for use in different categories of luminaires.

In general, the appropriate choice of components should be considered taking into account the following parameters.

- a) Micro-environment of the components
 - 1) Tracking (IEC 60112)
 - ordinary environments not requiring tracking test;
 - environments requiring tracking test at 175 V (i.e. CTI 175).
 - 2) Pollution degree (IEC 60664-1)
 - pollution degree 1;
 - pollution degree 2;
 - pollution degree 3;
 - pollution degree 4.
- b) Overvoltage category (IEC 60664-1)
 - overvoltage category I;
 - overvoltage category II;
 - overvoltage category III;
 - overvoltage category IV
- c) Fire resistance (IEC 60695-2 series)
 - glow-wire test 650 °C;
 - glow-wire test 850 °C.

J.8 Recommendations for electromagnetic ballast protection for end of life phenomenon of HID lamps

Because of the possible risk of ballast overloading at end of lamp life, suitably protected circuits should be used for operation of high-pressure sodium and some metal halide lamps.

Testing is conducted using the test circuit of Figure C.3.

It is generally accepted, for now, that it would be unlikely that normal magnetic ballast would meet this test requirement without the addition of a thermal cut-out.

J.9 Resistance against the effects of vibration

Luminaire construction should be resistant against the effects of vibration that are likely to occur in service and this is particularly relevant for street lighting (IEC 60598-2-3) and floodlights (IEC 60598-2-5). Because of differences in luminaire design, methods of mounting, and application conditions (location characteristics, anticipated weather conditions, etc.), the standardization of specific vibration test methods is not practical.

It is recommended that manufacturers study the vibration characteristics of luminaire design, fixing options and intended environments for use. From these characteristics, appropriate vibration testing that gives confidence of luminaire safety over product lifetime should be conducted.

In considering luminaire safety after vibration testing, the following checks may be appropriate:

- a) retention of components to their fixings within the luminaire;
- b) no abrasions or damage to wiring or component insulation;
- c) maintenance of electrical connections;
- d) maintenance of mechanical connections;
- e) maintenance of installation fixings;
- f) protection against ingress of dust and moisture to be maintained;
- g) maintenance of creepage and clearance distances;
- h) no movement or "set" in accordance with wind load testing (IEC 60598-2-3 and IEC 60598-2-5);
- i) no lamp breakage;
- j) lamp to remain in position;
- k) early signs of fatigue that can be propagated to cause a safety failure;
- l) no parts to become detached from the luminaire.

NOTE 1 Items i) and j) can be regarded as performance rather than safety factors in some instances.

NOTE 2 The effects of material performance degradation with age and use can also be considered.

NOTE 3 In some countries, national standards cover vibration testing of certain types of luminaire (e.g. in the USA, ANSI C136 Series; in Australia, AS 3771).

J.10 Flammability of components

Additional guidance for assessing fire hazards of electrotechnical products are contained in the IEC 60695 series, including the use of pre-selection testing procedures for insulating materials having certain characteristics relative to heat and fire resistance.

J.11 Permanent magnets

Suspension of luminaires, and parts of luminaires, with permanent magnets should be designed taking into account both magnets characteristics and their foreseen use.

The design of luminaires with permanent magnets for suspensions, should consider the following:

- a) permanent magnets are sensitive to temperature; the information regarding the maximum temperature allowed by their manufacturer should be considered;
- b) ambient temperature for which the luminaire is designed;
- c) external treatments of the permanent magnets; painting and other surface treatment can modify the permanent magnets characteristics. Mechanical (suspension) tests should be carried out in the final version of the part or component;
- d) the use of permanent magnets for outdoor applications should consider any possible modification of their characteristics due to oxidation and corrosion (information from magnet manufacturers should be considered);
- e) permanent magnets are sensitive to mechanical processing, which can cause degradation of their characteristics and a mechanical test should be carried out in the final stage of the suspension equipment;

- f) splintering of coating can damage the permanent magnets; suitable packaging during handling should be ensured;
- g) magnets can be used to carry current in circuits with power up to 15 W and 2 A as:
 - there is no effect on the initial magnetic force;
 - the change in magnetic force is sufficiently small even after long-term use;
 - the volume resistivity is sufficiently low.

NOTE Other features, not related to the requirements of this document can be considered (for example and as applicable, influence on people, nickel allergy, magnetic field).

IECNORM.COM : Click to view the full PDF of IEC 60598-1:2024

Annex K (normative)

Determination of creepage distances and clearances

Annex K and Table K.1 shall be used in conjunction with the creepage and clearance requirements of Clause 13.

**Table K.1 – Determination of creepage distances and clearances
(see Table 18, Table 19 and Table 20)**

Creepage distances and clearances between	Luminaires of class I	Luminaires of class II	Luminaires of class III
Maximum working voltage (not exceeding)	1 000 V	1 000 V	50 V AC or 120 V DC
(1) Live parts of different polarity	Basic insulation Creepage or clearance PTI ≥ or < 600	Basic insulation Creepage or clearance PTI ≥ or < 600	Basic insulation Creepage or clearance PTI ≥ or < 600
(2a) Live parts and accessible metal parts	Basic insulation Creepage or clearance PTI ≥ or < 600	Reinforced insulation or double insulation Creepage or clearance PTI ≥ or < 600	Basic insulation Creepage or clearance PTI ≥ or < 600
(2b) Live parts and the outer accessible surface of insulating parts	Reinforced insulation or double insulation ^a Creepage or clearance PTI ≥ or < 600	Reinforced insulation or double insulation Creepage or clearance PTI ≥ or < 600	Basic insulation Creepage or clearance PTI ≥ or < 600
(3) Parts which can become hazardous live parts due to the breakdown of basic insulation in luminaires of class II and accessible metal parts		Supplementary insulation Creepage or clearance PTI ≥ or < 600	
(4) The outer surface of a flexible cord or cable and an accessible metal part to which it is secured by means of a cord grip, cable carrier or clip of insulating material	Basic insulation ^b Creepage or clearance PTI ≥ or < 600	Supplementary insulation Creepage or clearance PTI ≥ or < 600	
(5) Live parts and other metal parts, between them and the mounting surface (ceiling, wall, table, etc.) or between live parts and the mounting surface where there is no intervening metal	Basic insulation Creepage or clearance PTI ≥ or < 600	Reinforced insulation or double insulation Creepage or clearance PTI ≥ or < 600	Basic insulation Creepage or clearance PTI ≥ or < 600

NOTE Columns 1 to 3 of this table gives details for the situations where no electrical insulation is provided between the mains supply and output circuits of the controlgear. Where the controlgear provides basic or double or reinforced insulation from the mains supply, the required insulation from the live part to the accessible part, including the mounting surface, can be different. As a consequence of the requirements according to Table T.1, the test voltage can be modified.

^a In Class I luminaires where the outer surface of insulating material is accessible with the test probe described in 10.2.1 (standard test finger according to IEC 61032:1997, Figure 2) for portable and adjustable luminaires, 50 mm probe according to IEC 61032:1997, Figure 1 for other types of luminaire), reinforced or double insulation is required.

^b In the case of a cable provided with two layers of insulation (insulation of the conductor and the external sheath), this requirement is fulfilled by the cable itself.

Annex L (informative)

Explanation of marking for luminaires that are not suitable for mounting on normally flammable surfaces and covering with insulation materials

L.1 General

When a luminaire is provided with the warning notice (as referred to in 6.3.9 and IEC 60598-2-2), this denotes that it is not suitable for direct mounting on normally flammable material or not suitable for covering with thermal insulation material, or both.

The use of the warning notice may be appropriate to all types of luminaires, including luminaires for incandescent lamps that are not suitable for mounting on normally flammable surfaces. See Table L.1.

Table L.1 – Guidance on when to use the symbol and its explanation on the luminaire or in the manufacturer's instructions provided with the luminaire

	Luminaire capability	Symbol and explanation
A	Surface mounted luminaires suitable for direct mounting on normally flammable surfaces	Nothing
B	Surface mounted luminaires not suitable for direct mounting on normally flammable surfaces (suitable only for mounting on non-flammable surfaces)	Apply the symbol and explanation
C	Recessed mounted luminaires suitable for mounting in, or on, normally flammable surfaces when thermally insulating material may cover the luminaire	Nothing
D	Recessed luminaires not suitable for mounting in, or on, normally flammable surfaces when thermally insulating material may cover the luminaires	Apply the relevant symbol(s) and explanation
E	Recessed luminaires not suitable for mounting in, or on, normally flammable surfaces yet otherwise comply	Apply the symbol and explanation

L.2 Protection against flame

Practical experience over the last ten years has shown no evidence in regard to the supposed emission of flames from ballast windings at the end of ballast life.

Other components, such as capacitors, are subjected to a destruction test to verify that these components will fail in a safe way.

Furthermore, bearing in mind that extinguishing properties of flammable luminaire materials are tested in accordance with 7.15, it was concluded that there was no evidence which justified to keep the requirement for intervening material between windings and mounting surface. This requirement was, therefore, deleted from the second edition of IEC 60598-1.

L.3 Protection against heat

L.3.1 General

To safeguard the mounting surface against excessive heat, three equivalent protection options are given by this document, at the discretion of the manufacturer:

- spacing;
- temperature measurement;
- thermal protector.

L.3.2 Spacing

The ballast or transformer is spaced from the mounting surface by a minimum distance of either:

- a) 10 mm, including a minimum of 3 mm air space between the outer surface of the luminaire case and the mounting surface of the luminaire, and a minimum of 3 mm air space between the ballast or transformer and the inner surface of the luminaire case.

If there is no ballast or transformer case, the distance of 10 mm shall apply from the active part, for example the winding of the ballast.

The luminaire case should be substantially continuous in the protected area of the ballast or transformer permitting a separation of less than 35 mm between the active part of the ballast or transformer and the mounting surface, otherwise the requirement of item b) applies. There are no requirements with regard to the substance of the luminaire case material, which can be insulating material complying with 7.15.

If there is no luminaire case between the ballast or transformer and the luminaire mounting surface, then the distance between the two should be at least 35 mm.

- b) 35 mm. The spacing of 35 mm is primarily to take into account stirrup-mounted luminaires where the ballast or transformer to the mounting surface distance is often much greater than 10 mm.

L.3.3 Temperature measurements of mounting surface under abnormal or failed ballast conditions

Temperature measurements can be carried out to verify that the luminaire mounting surface will not reach too high temperatures, whether under abnormal conditions or under failed ballast conditions.

These requirements and tests are based on the assumption that during failure of the ballast or transformer, for example owing to short-circuited windings, the ballast winding temperature will not exceed 350 °C for a duration of more than 15 min, and that the related temperature of the mounting surface will then not exceed 180 °C for a duration of more than 15 min.

Similarly, during abnormal ballast conditions, the temperature of the mounting surface shall not exceed 130 °C. At ambient temperature and at 1,1 times the supply voltage, the temperature of the windings and mounting surface are measured and plotted on a graph; then a straight line is drawn through these points. The extrapolation of this straight line shall not reach a point representing a mounting surface temperature of 180 °C at a winding temperature of 350 °C (see Figure L.1).

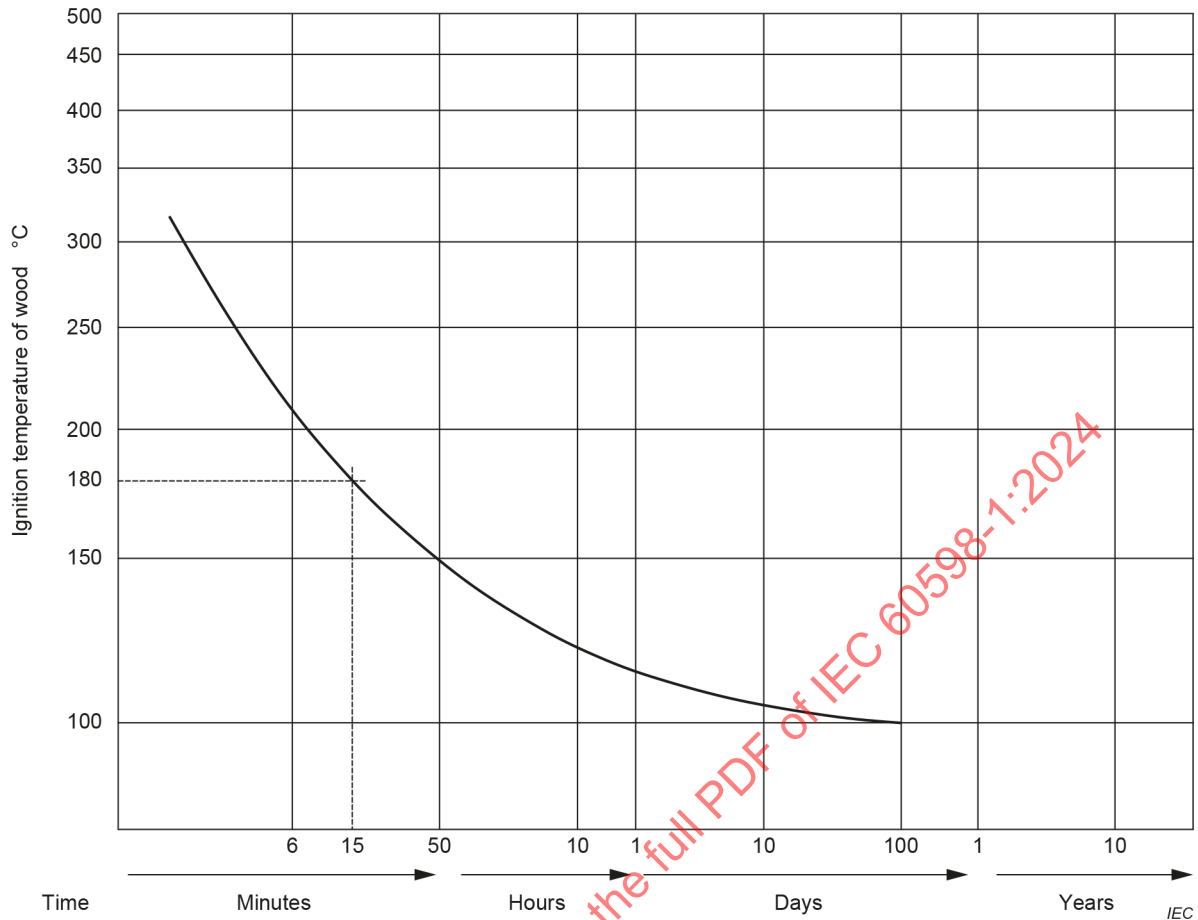

Figure L.2 – Ignition temperatures of wood as a function of time

L.4 Thermal protectors

Thermal protectors can be part of the controlgear or external to the controlgear.

Requirements for thermally protected controlgear are covered by the relevant controlgear standard.

Thermally protected controlgear are marked with the symbol ∇^P or ∇^{\dots} . The dots are replaced by the rated maximum case temperature in °C when the protector opens the circuit.

Thermally protected controlgear with the symbol ∇^P or ∇^{\dots} with values up to and including 130 °C provide complete protection of the luminaire mounting surface without any additional measures in the luminaire being necessary. This implies compliance on a time related basis with the maximum case temperature permitted under abnormal conditions i.e. 130 °C, and, under failed controlgear conditions, with a mounting surface temperature not exceeding 180 °C.

Thermally protected controlgear with a symbol ∇^{\dots} with values above 130 °C shall be checked in combination with the luminaire as specified for luminaires with a thermal protector external to the controlgear.

Luminaires with a thermal protector external to the controlgear, and luminaires with thermally protected controlgear with a marked value above 130 °C, are checked by measuring the temperature of the luminaire mounting surface until the thermal protector opens the circuit. During the test, the temperature of the luminaire mounting surface is recorded and shall not exceed the maximum temperature permitted under abnormal conditions, i.e. 130 °C, nor on a time related basis up to the maximum temperature under failed controlgear conditions (see Table L.2).

Table L.2 – Thermal protection operation

Maximum temperature of the mounting surface °C	Maximum time allowed for these temperatures to be present min
Over 180	0
Between 175 and 180	15
Between 170 and 175	20
Between 165 and 170	25
Between 160 and 165	30
Between 155 and 160	40
Between 150 and 155	50
Between 145 and 150	60
Between 140 and 145	90
Between 135 and 140	120

L.5 Deletion of the F mark requirements

The changes were introduced in the previous editions of IEC 60598-1. They simplify the structure of the requirements so that the expectation is that all products meet the most stringent requirements. If a product cannot meet this requirement, such as mounting on normally flammable surfaces, then it shall be marked accordingly. Therefore, these changes have moved from a mixture of both positive and negative markings to now follow IEC principles of only negatively marking.

The further complication of when a product has to comply with mounting on normally flammable surfaces but did not require to be marked (see for example the requirements for mains socket-outlet mounted nightlights) is now removed.

Annex M (normative)

Absorption requirements for the protective shield to be fitted to luminaires designed for metal halide lamps which emit a high level of UV radiation

M.1 General

Most metal halide lamps having a glass outer bulb emit only a low level of UV radiation and additional measures regarding UV absorption by the luminaire shield are not necessary. However, some metal halide lamps having a normal quartz outer bulb or no outer bulb emit a high level of UV radiation (greater than 6 mW/klm specific effective radiant UV power for lamps for general lighting).

In instances where lamp manufacturers provide a warning regarding the risk of UV radiation, see 7.21.1, Note 1 or, as referenced on the relevant lamp data sheet in IEC 61167 for standardized lamps, adequate protective UV absorption measures shall be provided in the luminaire. For the selection of the UV absorbing protective shield, one of the two following procedures shall be used.

NOTE These procedures only relate to possible hazards regarding UV exposure of human beings. They do not deal with the possible influence of optical radiation on materials, like mechanical damage or discoloration.

M.2 Procedure A

The maximum specific effective radiant UV power P_{eff} of the lamp shall be established from information to be supplied by the lamp manufacturer or, for standardized lamps, from data on the relevant lamp data sheet in IEC 61167. The specific effective radiant UV power of a lamp is its effective radiant UV power related to its luminous flux.

The maximum allowed UV transmission T of the luminaire shield shall be calculated as follows, taking into account the expected application of the luminaire:

$$T \leq 8\,000 / (P_{\text{eff}} \times t_e \times E_e)$$

where

T is the maximum allowed UV transmission for any wavelength between 200 nm and 315 nm,

P_{eff} is the specific effective radiant UV power of the lamp (in mW/klm);

t_e is the expected maximum exposure time per day in the application (in h);

E_e is the expected maximum illuminance in the application (in lx).

If the maximum exposure time in the application cannot be estimated, and since daily exposure times longer than 8 h do not require consideration, the most onerous requirement is given by:

$$T \leq 1\,000 / (P_{\text{eff}} \times E_e)$$

A shield shall be chosen that, according to the glass manufacturer, has a maximum UV transmission for any wavelength between 200 nm and 315 nm not exceeding the calculated maximum allowed UV transmission value T .

M.3 Procedure B

The above calculation procedure is based on the value of the effective UV radiation related to the effective visible radiation of a bare lamp. Any spectral influence of reflective materials inside the luminaire is neglected.

However, in most cases, reflections inside the luminaire will absorb the UV radiation stronger than the visible radiation, resulting in less UV radiation from the luminaire than calculated with procedure A. If necessary, and in case of doubt, this influence can be taken into account by making spectral measurements of the irradiance from the luminaire in the UV and visible region.

In the UV region between 200 nm and 315 nm, the measured spectral irradiance shall be weighted with the UV hazard function $S(\lambda)$ for unintended UV, giving the effective UV irradiance. In the visible region, it shall be weighted with the spectral luminous efficiency $V(\lambda) \times 683$, giving the effective visible irradiance, i.e. the illuminance. The ratio of the two values is E_{eff} , the specific effective UV irradiance, which is the effective UV irradiance from the luminaire related to its illuminance.

NOTE Information about the relevant UV hazard function $S(\lambda)$ is given in IEC 62471. The action spectrum $S(\lambda)$ extends from 200 nm to 400 nm, but weighting between 200 nm and 315 nm will suffice for light sources.

The result of the direct measurement from the luminaire shall comply with the following requirement, taking account the expected application of the luminaire:

$$E_{\text{eff}} \leq 8\,000 / (t_e \times E_e)$$

where

E_{eff} is the measured specific effective UV irradiance from the luminaire [in $\text{mW}/(\text{m}^2 \cdot \text{klx})$];

t_e is the expected maximum exposure time per day in the application (in h);

E_e is the expected maximum illuminance in the application (in lx).

If the maximum exposure time in the application cannot be estimated, the most onerous requirement in this case is given by:

$$E_{\text{eff}} \leq 1\,000 / E_e$$

Annex N (informative)

Conformity testing during manufacture

N.1 General

The tests specified in Annex N should be carried out by the manufacturer on each luminaire after production and are intended to reveal, as far as safety is concerned, unacceptable variations in material and manufacture. These tests are intended not to impair the properties and the reliability of the luminaire, and they vary from certain type tests in this document by the lower voltages utilized.

More tests will possibly have to be conducted to ensure that every luminaire conforms with the sample approved under the type test to this document. The manufacturer should determine these tests from experience.

Within the framework of the quality manual, the manufacturer may vary this test procedure and its values to one better suited to his production arrangements, and may make certain tests at an appropriate stage during manufacture, provided it can be proved that at least the same degree of safety is ensured as specified in Annex N.

N.2 Testing

Electrical tests should be conducted on 100 % of all units produced as scheduled in Table N.1. Failed products should be quarantined for scrap or rebuild.

Visual inspection should take place to ensure that:

- a) all specified labels are securely in place;
- b) the manufacturer's instructions are placed within the luminaire, where necessary;
- c) the luminaire is complete, and that mechanical check against a checklist for the product has been carried out.

All products passing these tests should be suitably identified.

Table N.1 – Minimum values for electrical tests

Test	Class of luminaire and compliance			
	Class I luminaires	Class II luminaires metal encased	Class III metal encased with supply > 25 V AC (RMS) or 60 V DC, ripple free	Class II and class III luminaires insulation encased
Function test or circuit continuity (with lamp or simulation lamp)	Generally at normal operating voltage			
Earth continuity Applied between earthing terminal on luminaire and the most accessible parts likely to become hazardous live parts. Settable and adjustable luminaires placed in most onerous position.	Maximum resistance 0,50 Ω Measured by passing a minimum current of 10 A from a power source providing an open circuit voltage between 6 V and 12 V ^a	Not applicable (except where protective earth continuity is provided, in this case, the test for class I is applicable)	Not applicable	Not applicable
a) Electric strength or b) Insulation resistance Measured between the line and neutral terminals linked together and the earth terminal or between the conductors of class II and class III luminaires and the metal enclosure	Maximum breakdown current 5 mA Measured by applying a minimum voltage of 1,5 kV AC or 1,5 √2 DC kV ^a or Minimum resistance 2 MΩ Measured by applying 500 V DC ^a	Maximum breakdown current 5 mA Measured by applying a minimum voltage of 1,5 kV AC or 1,5 √2 DC kV ^a or Minimum resistance 2 MΩ Measured by applying 500 V DC ^a	Maximum breakdown current 5 mA Measured by applying a minimum voltage of 400 V AC or 400 √2 DC V ^a or Minimum resistance 2 MΩ Measured by applying 100 V DC ^a	Not applicable
Polarity Tested at incoming terminals	Where necessary for correct functioning of luminaire	Not applicable		
Electric strength testers whose voltage can be applied to luminaires when supply voltage is in zero crossing is recommended to avoid unintended damage of the DUT due to resonant phenomena.				
^a The tests should be performed for at least 1 s. The duration of tests can be reduced to 0,1 s as a minimum value, if it is shown that the time is sufficient to achieve and reliably reproduce the same results that would be achieved after 1 s to detect possible manufacturing defects.				

Annex O (normative)

Schedule of amended subclauses containing more serious or critical requirements which call for products to be retested

The following schedule of subclauses details the more serious or critical requirements of this tenth edition of IEC 60598-1 when compared to the previous ninth edition. These requirements may call for products to be retested when updating product certification. It is possible that retesting will not be required in all cases depending on the construction of the luminaire and the analysis of previous test results.

Subclause 7.32: for SPDs and SPCs;

Subclause 7.14.2: for special cables or cords with additional metallic wires or non-metallic fibres twisted together;

Subclause 14.5.2 (abnormal operation condition): to include luminaires with electronic step-down convertor;

Subclauses 7.11.4; 7.14.1; Table 22 (14.4.3): for suspension by magnets;

Subclauses 4.2.2; 4.3.4; 6.3.8 b) and Annex W: for battery operated luminaires;

Subclause 7.31.5: Additional requirement for luminaires using controllable controlgear providing SELV output(s);

Subclause 6.4.16: Information to be provided for luminaires with a protective earth current > 10 mA;

Subclauses 6.3.23; 6.4.18; 6.4.24; 7.30 and 10.2.1 for serviceable, non-user serviceable and non-serviceable components;

Subclauses 7.8 and Table 21 (14.4.3) for luminaire incorporating switches according to IEC 60669-1 or IEC 60669-2-1;

Subclause 6.3.27 for marking of mains socket outlet.

Annex P (normative)

Requirements for the identification of a family or range of luminaires for type testing

P.1 General

When selecting type test sample(s) from a range of luminaires of similar construction for type test verification, the luminaire(s) chosen shall be those which represent the most unfavourable combination of components and housing.

P.2 Range or family of luminaires

A range or family of luminaires of similar construction shall be considered to be:

- a) in compliance with the same applicable part of the IEC 60598-2 series;
- b) equipped with lamps of the same nature, such as:
 - 1) tungsten including tungsten-halogen lamps;
 - 2) fluorescent lamps;
 - 3) discharge lamps;
 - 4) LED lamps and modules;
- c) within the same class of protection against electrical shocks;
- d) within the same IP classification.

Each range of luminaires requires a case-by-case consideration. The range of luminaires should be manufactured by the same manufacturer, under the same quality assurance system. The type variants of the range should be essentially identical with respect to materials used, components and technology applied. Type test sample(s) should be selected with the cooperation of the manufacturer and the testing station.

Annex Q
(informative)

Additional requirements for luminaires where a higher degree of availability (overvoltage category III) may be requested

Q.1 General

Clearance limits detailed in Clause 13 have been established with reference to the IEC 60664 series and are based on overvoltage category II. This level of overvoltage category is considered appropriate to normal usage of luminaires covered under the scope of the IEC 60598 series. Annex Q details the more onerous requirements of the IEC 60664 series which would allow luminaires to have a higher overvoltage capability for an overvoltage category III, should a higher degree of overvoltage category be requested.

Q.2 Requirements for overvoltage category III

Increased clearance requirements for overvoltage category III are given in Table Q.1. These limits are applied in place of those given in Table 19, should a rating of overvoltage category III be requested.

Creepage limits remains those required in 13.2.2, taking into account that creepage distances shall not be less than the required minimum clearance.

For details of pollution degrees or overvoltage categories, IEC 60664-1 should be consulted.

The minimum distances specified are based on the following parameters:

- for use up to 2 000 m above sea level;
- pollution degree 2 where normally only non-conductive pollution occurs but occasionally a temporary conductivity caused by condensation is to be expected;
- equipment of overvoltage category III which is equipment in fixed installations and for cases where the reliability and the availability of the equipment is subject to special requirements.

Table Q.1 – Minimum clearance distances for AC sinusoidal working voltages overvoltage category III

Distances mm	RMS working voltage not exceeding V				
	50	150	300	600	1 000
Clearances with mains supply transients according to overvoltage category III ^b					
– Basic and supplementary insulation	0,2	1,5	3,0	5,5	8,0
– Reinforced insulation	0,5	3,0	5,5	8,0	14
Clearances without mains supply transients ^{a b}					
– Basic or supplementary insulation	0,2	0,2	0,2	0,2	0,7
– Reinforced insulation	0,2	0,2	0,2	0,6	1,6
^a The values in this row are applicable to circuits where it is ensured that they are free from transient (e.g. battery circuits). ^b For clearances, the equivalent DC voltage is equal to the peak of the AC voltage. Interpolation between columns is not allowed.					

For overvoltage category III luminaires the insulation requirements, as detailed in Table 4, are replaced as shown in Table Q.2 below.

Table Q.2 – Overview of required Y capacitors

AC mains voltage RMS ^a	Bridged insulation	Capacitor type	Required number of capacitors
$U \leq 150 \text{ V}$	B or S	Y4	1
$U \leq 150 \text{ V}$	B or S	Y2	1
$U \leq 150 \text{ V}$	B or S	Y1	1
$U \leq 150 \text{ V}$	D or R	Y4	2
$U \leq 150 \text{ V}$	D or R	Y2	2
$U \leq 150 \text{ V}$	D or R	Y1	1
$150 \text{ V} < U \leq 300 \text{ V}$	B or S	Y2	1
$150 \text{ V} < U \leq 300 \text{ V}$	B or S	Y1	1
$150 \text{ V} < U \leq 300 \text{ V}$	D or R	Y2	2
$150 \text{ V} < U \leq 300 \text{ V}$	D or R	Y1	1
$300 \text{ V} < U \leq 500 \text{ V}$	B or S	Y2	2
$300 \text{ V} < U \leq 500 \text{ V}$	B or S	Y1	1
$300 \text{ V} < U \leq 500 \text{ V}$	D or R	Y2	3
$300 \text{ V} < U \leq 500 \text{ V}$	D or R	Y1	2

Key

B basic insulation
S supplementary insulation
R reinforced insulation
D double insulation

^a In the case of capacitors connected between live parts of circuits insulated from the mains and accessible parts, the voltage to be considered is the voltage indicated in Table T.1.

For overvoltage category III luminaires the required SPC surge capabilities, as detailed in 7.32.3.4, Table 10, are replaced as shown in Table Q.3 below.

Table Q.3 – Nominal discharge current (used in the combination wave test)

Mains supply voltage	Combination pulse (open circuit voltage short-circuit current)
$\leq 300 \text{ V}$	4 kV 2 kA
$> 300 \text{ V}$ and $\leq 600 \text{ V}$	6 kV 3 kA
$> 600 \text{ V}$ and $\leq 1\,000 \text{ V}$	8 kV 4 kA

Annex R (normative)

Additional test requirements for terminal blocks with integrated screwless protective earthing contact for direct connection to the luminaire housing or to parts of the body

R.1 Additional requirements to 9.2.1

R.1.1 Requirements for mechanical strength

The earthing connections shall not be impaired by mechanical stress, for example during the connection of the line and neutral conductors to a common terminal block.

An integrated screwless protective earthing contact for direct connection to the luminaire housing or to parts of the body shall perform a permanent and reliable connection between the terminal and the supporting plate. It shall not be possible to loosen the connection without a tool. The screwless protective earthing contact on outer surfaces of the luminaire shall be protected against mechanical stress and damage from outside the luminaire by means of constructional design. Mechanical stresses can occur when the luminaire touches other objects (e.g. mounting surface). Terminal blocks with integrated screwless earth contact shall be mounted in accordance with the instructions of the manufacturer.

Compliance is checked by inspection and by the tests of R.1.2 and R.1.3. For each test of R.1.2 and R.1.3, the resistance between the earth connection of the terminal and the supporting plate shall not exceed $0,05 \Omega$ after the test.

R.1.2 Test for terminal fixing

The secure fixing of the terminal block to the supporting plate is checked by a pull test. The terminal is fitted with a solid conductor having the largest cross-sectional area for which the terminals are rated. A pull test load of 20 N is applied to the most unfavourable direction between the terminal block and the supporting plate. After the test, the terminal block shall be in place.

R.1.3 Test for supporting plate

For this test, the terminal block shall be held only by the earthing contact with the fixing supports provided after the insulating material is removed. A pull test load of 50 N is applied to the centre of the earthing contact in the opposite direction of insertion for at least 1 min. The screwless protective earthing contact shall not be damaged after the test and the connection to the supporting plate shall not loosen.

R.2 Additional requirements to 9.2.3

The test requirements for the electrical connection are:

The integrated screwless protective earthing contact for direct connection to the luminaire housing or to parts of the body is submitted to a voltage drop test. For testing, the terminal block is mounted onto a supporting plate with the lowest thickness according to the manufacturer's specifications and it is fitted with a solid conductor having the largest cross-sectional area for which the terminals are rated. The voltage drop is measured over the U_{cs} -path as shown in Figure R.1. The measurement is performed as described in 9.2.3. If the resistance to the supporting plates of any of the terminal blocks exceeds $0,05 \Omega$, the terminal blocks are rejected.

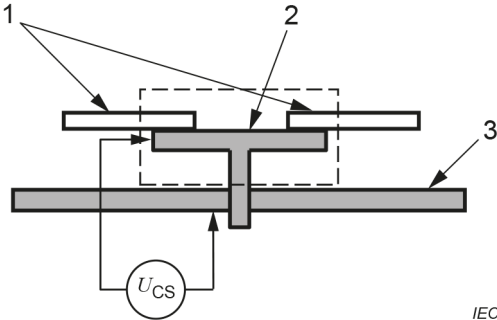

Key

- 1 conductor
- 2 terminal
- 3 supporting plate
- U_{cs} voltage drop between conductor and supporting plate

Figure R.1 – Arrangement for voltage drop test

IECNORM.COM : Click to view the full PDF of IEC 60598-1:2024

Annex S (normative)

Alternative thermal test for thermoplastic luminaires

S.1 General

The following test method can be used as an alternative to the reference test of 14.7.2.1 for luminaires without temperature sensing controls, incorporating fluorescent lamp ≤ 70 W. In case of doubt, the test method of 14.7.2.1 applies.

S.2 Thermal test in regard to fault conditions in controlgear or electronic devices without temperature sensing controls in thermoplastic luminaires for fluorescent lamps ≤ 70 W

The luminaire shall be tested under the conditions specified in 14.4.2, items a), c), e), f) and h). In addition, the following applies.

20 % of the lamp circuits in the luminaire, and not less than one lamp circuit, shall be subjected to abnormal conditions (see 14.5.2 item a)).

The circuits which have the most thermal influence on the fixation point and exposed parts shall be chosen and other lamp circuits shall be operated at rated voltage under normal conditions.

The circuits subjected to the above conditions shall then be operated at 0,9, 1,0 and 1,1 times the rated voltage (or the maximum of the rated voltage range). When conditions are stable at each of these three test voltages, the highest winding temperature and the highest temperature of fixing points or most thermally influenced exposed parts shall be measured. It is not necessary to measure the temperature of small wound devices that are incorporated within electronic circuits.

For fluorescent lamp luminaires with an AC supplied electronic controlgear incorporating a filter coil, the voltage required to give nominal operating current shall be determined. The filter coil shall be operated at 0,9, 1,0 and 1,1 times this voltage. When conditions are stable at each of these three test voltages, the highest winding temperature and the highest temperature of fixing points and most thermally influenced exposed parts shall be measured. All other parts of the controlgear and lamp shall be inoperative for this test.

Compliance:

The values of temperature measured at 0,9, 1,0 and 1,1 times the rated voltage (or the maximum of the voltage range) are used for the linear regression formula in calculating the temperature of fixing points and other exposed parts in relation to a ballast or transformer winding temperature of 350 °C. If the difference between winding temperature measurements at 0,9 and 1,1 co-ordinates is less than 30 K, a fourth point is added, whose co-ordinates are winding t_a , fixing or exposed part t_a . The thermoplastic material is then subjected to the ball pressure test as described in 15.2.2 at the estimated temperature determined by linear regression, but not less than 75 °C. The diameter of the impression shall be measured and shall not exceed 2 mm.

This is a fault condition test and the additional 25 °C of 15.2.2 does not apply. In applying the requirements of 7.15 and 14.7, the following shall be referred to.

- "Fixing points" means both the fixing points of components and the fixing points of a luminaire to the mounting surface.
- "Exposed part" means the outer surface of the luminaire enclosure.
- According to the requirements of 14.7, measurement of exposed parts is restricted to those parts providing the luminaire or component fixing or parts providing a protective barrier against accidental contact with hazardous live parts, as required by Clause 10.
- The hottest part of the thermoplastic material section requiring the test is measured. This can often be on the internal surface of a luminaire enclosure not the outer surface.
- The material temperature limits defined are with respect to materials under both mechanical load and no mechanical load.
- t_a is the rated t_a of the luminaire.

IECNORM.COM : Click to view the full PDF of IEC 60598-1:2024

Annex T (normative)

Requirements for insulation between live parts of circuits and accessible conductive parts

See 7.31 and Figure T.1.

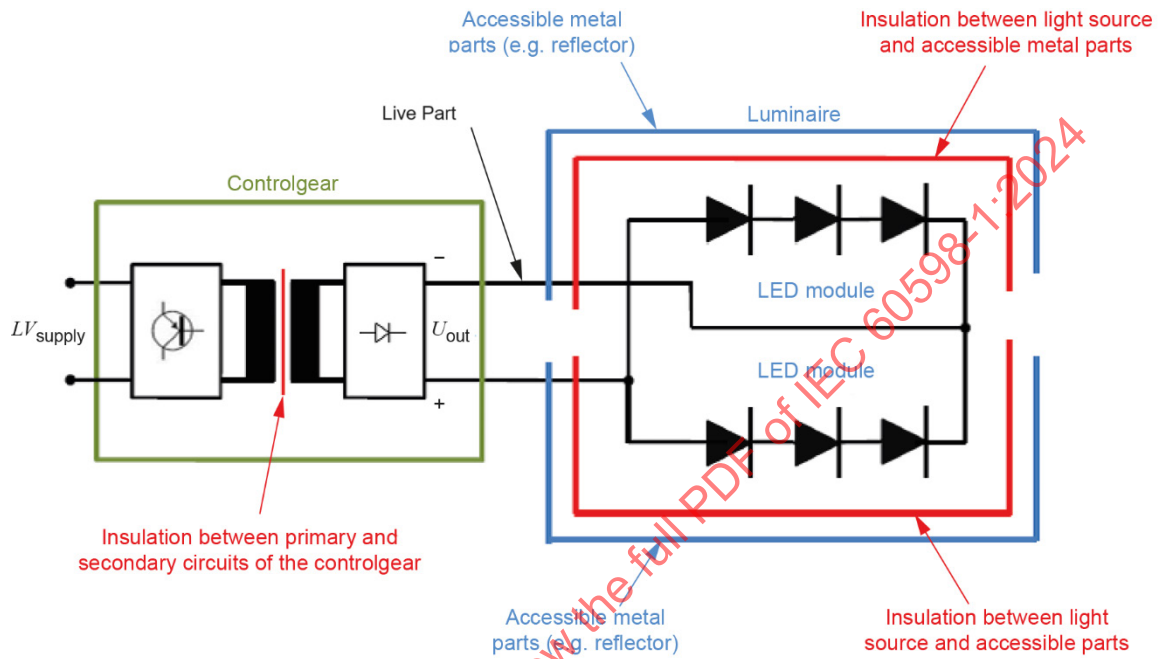

Figure T.1 – Declaration of LV_{supply} and U_{out} and the insulation barriers between the light source and accessible parts

IECNORM.COM : Click to view the full PDF of IEC 60598-1:2024

Table T.1 – Insulation requirements between live parts and accessible conductive parts

Controlgear		Required insulation between live parts and accessible conductive parts		
Insulation between mains supply and secondary circuits	Output voltage	Class I Insulation of accessible earthed conductive parts	Class II Insulation of one accessible conductive part or more than one with equipotential bonding	Class II Insulation of more than one accessible conductive part without equipotential bonding
None	$U_{out} >$ mains supply	Basic insulation complying with U_{out}	Double or reinforced insulation complying with U_{out}	Double or reinforced insulation complying with U_{out}
	$U_{out} \leq$ mains supply	Basic insulation complying with mains supply	Double or reinforced insulation complying with mains supply	Double or reinforced insulation complying with mains supply
Basic	Voltages above ELV	Basic insulation complying with U_{out}	Supplementary insulation complying with U_{out} plus mains supply	Insulation shall fulfil the higher requirement of a) or b): a) Supplementary insulation complying with U_{out} plus mains supply b) Double or reinforced insulation complying with U_{out}
	ELV (FELV)	Basic insulation complying with U_{out}	Supplementary insulation complying with U_{out} plus mains supply	Supplementary insulation complying with U_{out} plus mains supply
Double or reinforced	Voltages above ELV	Basic insulation complying with U_{out}	Basic insulation complying with U_{out}	Double or reinforced insulation complying with U_{out}
	ELV (SELV or PELV)	Basic insulation complying with U_{out} See also requirements in Clause 10, Clause 12 and Clause 13 ^a	Basic insulation complying with U_{out} See also requirements in Clause 10, Clause 12 and Clause 13 ^a	Basic insulation complying with U_{out} See also requirements in Clauses 10, Clause 12 and Clause 13 ^a
In this Table T.1, the sum of voltages is required. For technical background, IEC TR 63139 should be consulted.				
NOTE Table T.1 is an overview of the requirements already given in this document, it does not amend or add to these requirements.				
^a This requirement does not exclude the connection of the PELV circuits to earth for functional purposes.				

Annex U (informative)

Information regarding power sourcing equipment powering class III luminaires via information technology communication cabling

U.1 General

Annex U describes the relevant properties of a PSE supplying a luminaire with a DC voltage, with a maximum rated voltage of 60 V DC. The power is supplied via communication cabling including the appropriate connectors, for instance plugs described in the IEC 60603 series and the IEC 62680 series.

The requirements for the PSE are given in IEC 62368-3:2017, Clause 5.

NOTE A self-adjusting power supply can support a range of different nominal output power levels via negotiation with the luminaire. It is not always known what type of luminaire will be attached; the voltage of the power supply under single fault conditions will be limited to 130 % of the nominal output voltage that was active at the time of the single fault condition. This means that the luminaire will be safe when supplied with an input voltage of 130 % of the rated voltage of the luminaire.

U.2 Insulation of the mains supply

A PSE is single fault proof, meaning it has two lines of defence, for example double or reinforced insulation from the mains supply.

U.3 Electrical limits of a PSE

Limits for the electrical parameters of a PSE are given in Table U.1.

Table U.1 – Limits for the electrical parameters of a PSE

Output voltage U V DC	Output current I A	Power P W
$U \leq 30$	$\leq 8,0$	≤ 100
$30 < U \leq 60$	$\leq 150/U$	≤ 100
NOTE The maximum current can be limited by the performance requirements for the communication cable, e.g. for Ethernet cables the maximum current in a twisted pair wire is 0,75 A per wire.		

The voltage of the power supply under single fault conditions will be limited to 130 % of the nominal output voltage that was active at the time of the single fault condition. This means that the luminaire will be safe when supplied with an input voltage of 130 % of the rated voltage with a minimum of 7,5 V DC. For voltages below 5 V DC, the voltage limitation is to 150 %.

NOTE 1 For USB connectors the initial voltage is 5 V DC with a maximum of 15 W. When more than 15 W is required, the controlgear will be able to communicate with the power supply. The voltage will then depend upon the required power, with a maximum of 20 V DC.

NOTE 2 For power over Ethernet the initial voltage is below 10 V DC with a power below 10 mW. When it is detected that a luminaire, suited for PoE, is present, due to negotiation between power supply and luminaire, the voltage can reach 57 V DC. If there is no luminaire suited for PoE, the power is not applied.

In Table U.2 an overview is given of the nominal electrical parameters which can be requested on the input of the class III luminaire.

Table U.2 – Electrical parameters for communication cables or connectors

Technology	Type of cable or connector	Voltage range	Current range	Power range
USB power delivery types	Micro-USB	5 V to 20 V	≤ 3 A	≤ 60 W
	Type A/B	5 V to 20 V	≤ 5 A	≤ 100 W
	Type C (standard cable)	5 V to 20 V	≤ 3 A	≤ 60 W
	Type C (active cable)	5 V to 20 V	≤ 5 A	≤ 100 W
Ethernet	Type 1 (IEEE 802.3af) RJ45	37,0 V to 57,0 V	≤ 350 mA	≤ 15,4 W
	Type 2 (IEEE 802.3at) RJ45	42,5 V to 57,0 V	≤ 600 mA	≤ 30 W
	Type 3 (IEEE 802.3bt) RJ45	42,5 V to 57,0 V	≤ 600 mA per pair	≤ 60 W
	Type 4 (IEEE 802.3bt) RJ45	41,1 V to 57,0 V	≤ 960 mA per pair	≤ 100 W

IECNORM.COM : Click to view the full PDF of IEC 60598-1:2024

Annex V (informative)

Cross-references to the previous edition of IEC 60598-1

Table V.1 lists the new clause, subclause, annex, table and figure numbers with respect to IEC 60598-1:2020 (Edition 9). The information given in Annex V should be used to enable the use of already published standards in the IEC 60598-2 series with the new format of this tenth edition of IEC 60598-1.

NOTE Future standards in the IEC 60598-2 series will be aligned with the structure of this document.

Table V.1 – Cross-references

IEC 60598-1:2020 Edition 9	IEC 60598-1:2024 Edition 10	Notes
SECTION 0		
0.1	Introduction and Clause 1	
0.2	Clause 2	
0.3	Clause 4	
0.3.1, 0.3.2 and 0.3.3	4.1	
0.4	4.2	
0.5	4.3	
0.6	Introduction	
0.7	4.4	
SECTION 1	Clause 3	
SECTION 2	Clause 5	
2.1 to 2.5	5.1 to 5.5	
SECTION 3	Clause 6	
3.1 to 3.4	6.1 to 6.5	
SECTION 4	Clause 7	
4.1 to 4.36	7.1 to 7.36	
SECTION 5	Clause 8	
5.1 to 5.4	8.1 to 8.4	
SECTION 6 Void	–	Deleted
SECTION 7	Clause 9	
7.1 to 7.2	9.1 to 9.2	
SECTION 8	Clause 10	
8.1 to 8.2	10.1 to 10.2	
SECTION 9	Clause 11	
9.1 to 9.3	11.1 to 11.3	
SECTION 10	Clause 12	
10.1 to 10.3	12.1 to 12.3	
SECTION 11	Clause 13	
11.1 to 11.2	13.1 to 13.2	
SECTION 12	Clause 14	
12.1 to 12.7	14.1 to 14.7	
SECTION 13	Clause 15	

IEC 60598-1:2020 Edition 9	IEC 60598-1:2024 Edition 10	Notes
13.1 to 13.4	15.1 to 15.4	
SECTION 14	Clause 16	
14.1	16.1	
14.2	Clause 3	
14.3	16.2	
14.4	16.3	
SECTION 15	Clause 17	
15.1	17.1	
15.2	Clause 3	
15.3 to 15.6	17.2 to 17.5	
Annex A	Annex A	No change
Annex B	Annex B	No change
Annex C	Annex C	No change
Annex D	Annex D	No change
Annex E	Annex E	No change
Annex F	Annex F	No change
Annex G	Annex G	No change
Annex H (Void)		Deleted
Annex I (Void)		Deleted
Annex J	Annex H	
Annex K	Annex I	
Annex L	Annex J	
Annex M	Annex K	
Annex N	Annex L	
Annex O (Void)		Deleted
Annex P	Annex M	
Annex Q	Annex N	
Annex R	Annex O	
Annex S	Annex P	
Annex T (Void)		Deleted
Annex U	Annex Q	
Annex V	Annex R	
Annex W	Annex S	
Annex X	Annex T	
Annex Y	Annex U	
	Annex V	New annex
	Annex W	New annex
Figure 1 to Figure 34		Symbols and figures repositioned within the text
Table 3.1	Table 1	
	Table 2	New table
Table 3.2	Table 3	
Table 4.6	Table 4	
Table 4.1	Table 5	

IEC 60598-1:2020 Edition 9	IEC 60598-1:2024 Edition 10	Notes
Table 4.2	Table 6	
Table 4.3	Table 7	
Table 4.4	Table 8	
Table 4.5	Table 9	
	Table 10	New table
Table 5.1	Table 11	
Table 5.3	Table 12	
Table 5.2	Table 13	
Table 9.1	Table 14	
Table 10.1	Table 15	
Table 10.2	Table 16	
Table 10.3	Table 17	
Table 11.1.A	Table 18	
Table 11.1.B	Table 19	
Table 11.2	Table 20	
Table 12.1	Table 21	
Table 12.2	Table 22	
Table 12.3	Table 23	
Table 12.4	Table 24	
Table 12.5	Table 25	
Table 12.6	Table 26	
Table 14.1	Table 27	
Table 14.2	Table 28	
Table 14.3	Table 29	
Table 14.4	Table 30	
Table 14.5	Table 31	
Table 15.1	Table 32	
Table 15.2	Table 33	

IECNORM.COM Click to view the full PDF of IEC 60598-1:2024

Annex W (normative)

Battery/EDLC-operated luminaires

W.1 General

Annex W specifies additional requirements for luminaires or their accessories (e.g. remote control) containing or operating from batteries/EDLCs.

NOTE Where it says "luminaire" in Annex W it is understood that it is also applicable to accessories (e.g. remote control).

Annex W is applicable to luminaires using replaceable, non-user replaceable and non-replaceable batteries, rechargeable and non-rechargeable batteries, EDLCs.

Annex W provides requirements for battery/EDLC chargers when incorporated in the luminaire. It does not cover remote battery/EDLC chargers.

Annex W does not cover requirements for emergency lighting luminaires which are covered by IEC 60598-2-22.

W.2 General test requirements and verification

Luminaires with non-replaceable and non-user replaceable batteries/EDLCs are tested with the battery or EDLC fully charged.

Where it is specified in the requirements that the battery provided with or intended for the appliance may be replaced with an artificial source, that source shall consist of a DC power supply or a specially constructed battery, the output of each having the characteristics described in Table W.1 for the relevant battery type. The worst case short-circuit current (I_{SC} (low) or I_{SC} (high)) shall be selected from the values in Table W.1.

Table W.1 – Artificial source characteristics

Battery type	Initial open circuit voltage with a tolerance of $\pm 10\%$ V	I_{SC}^a (low) with a tolerance of ${}^0_{-25}\%$ A	I_{SC}^a (high) with a tolerance of ${}^{+25}_0\%$ A	Minimum capacity Ah ^c	IEC references ^b
Rechargeable	Fully charged battery voltage	$0,5 \times I_{SC}$ of battery provided	$2,0 \times I_{SC}$ of battery provided	300 % of capacity of battery provided measured at 1 A and 0,9 V/cell cut-off	
Non-rechargeable AAA ^d	1,5	3	10	0,5	LR03
Non-rechargeable AA ^d	1,5	5	15	1,0	LR6
Non-rechargeable C ^d	1,5	5	15	3,0	LR14
Non-rechargeable D ^d	1,5	6	20	10	LR20
Non-rechargeable PP3 ^d (9 V)	9,0	0,6	6	0,5	6LR61
Non-rechargeable (other)	Nominal battery voltage	$0,5 \times I_{SC}$ of battery provided	$2,0 \times I_{SC}$ of battery provided	200 % of capacity of battery provided measured at 1 A and 0,9 V/cell cut-off	-
<p>NOTE 1 I_{SC} limits are specified for those batteries likely to be replaced with others of the same type but of differing performance.</p> <p>NOTE 2 The specified Ah values are based upon a nominal 1 A discharge current with a 0,9 V/cell end-of-discharge voltage except for PP3 (9 V), which is based upon a 0,1 A discharge current with a 0,9 V/cell end-of-discharge voltage.</p> <p>NOTE 3 As used in this table, "provided" means either the battery that is provided with the appliance or, if not provided, the battery that is intended or specified to be used with the luminaire.</p>					
<p>^a The short-circuit current (I_{SC}) is measured after $1 \text{ s} \pm 0,2 \text{ s}$ into a resistance of $10 \text{ m}\Omega \pm 2 \text{ m}\Omega$. Ensure that the self-heating of the resistance is managed to minimize the variability on the current during the tests.</p> <p>^b References are taken from IEC 60086-1.</p> <p>^c If the measured capacity is less than 50 % of the capacity specified by the battery manufacturer, calculation of the minimum capacity shall be based on the capacity specified by the battery manufacturer instead of the measurement.</p> <p>^d The non-rechargeable types specified are for alkaline types only.</p>					

W.3 Marking

W.3.1 General

The marking to be observed when replacing batteries, shall be according to W.3.3, W.3.4, W.3.5 and W.3.6.

Instructions shall be delivered with the luminaire in the form of an instruction paper or on the packaging.

W.3.2 Luminaires with replaceable battery

The instructions for luminaires incorporating replaceable batteries shall include the following information:

- the types of batteries that may be used and a warning that fire or explosion can result from the use of the incorrect battery;
- the orientation of the battery with regard to polarity;
- how to remove and insert the batteries;
- if the product is not suitable for non-rechargeable batteries;
- WARNINGS stating:
 - Non-rechargeable batteries are not to be recharged.
 - Supply terminals are not to be short-circuited.
 - Different types of batteries are not to be mixed.
 - New and used batteries are not to be mixed.
 - Keep batteries out of reach of children.

W.3.3 Coin and button batteries

Luminaires using replaceable coin and button batteries shall carry the substance of the following warning, positioned in accordance with 6.2, item c).

WARNING – Contains coin or button battery. Hazardous if swallowed – see instructions.

Alternatively, the luminaire shall be marked with the following symbol ISO 7000-0790 and caution sign ISO 7000-0434A.



Read operator's manual (SOURCE: ISO 7000-0790:2004-01)



Caution (SOURCE: ISO 7000-0434A:2004-01)

in conjunction with a supplementary sign containing a coin or button battery symbol as appropriate.

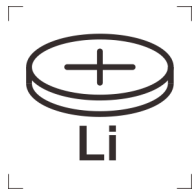

Coin battery (SOURCE: IEC 60417-6367:2017-11)



Button battery (SOURCE: IEC 60417-6368:2017-11)

The combination sign is to meet the rules in ISO 3864-1. This sign shall be placed next to symbol ISO 7000-0790.

Luminaires using replaceable coin or button batteries shall carry the substance of the following warnings in the instructions:

WARNING – This product contains a coin or button battery. A coin or button battery can cause serious internal chemical burns or death if swallowed.

WARNING – Dispose of used batteries immediately. Keep new and used batteries away from children. If you think batteries might have been swallowed or placed inside any part of the body, seek immediate medical attention.

NOTE Coin and button battery designations are defined in IEC 60086-1.

Compliance is checked by inspection.

W.3.4 Other standardized batteries (e.g. AAA or AA)

The battery compartment incorporating batteries that are intended to be replaced by the user shall be marked with the battery voltage and the polarity of the terminals positioned in accordance with 6.2, item a).

If colours are used, the positive terminal shall be identified in red and the negative terminal in black. Colour shall not be used as the only indication of polarity.

If more than one battery is used, the battery compartment shall be marked with the shape of the batteries in proportional size, together with their nominal voltage and polarity.

Compliance is checked by inspection.

NOTE Examples representing three batteries are:

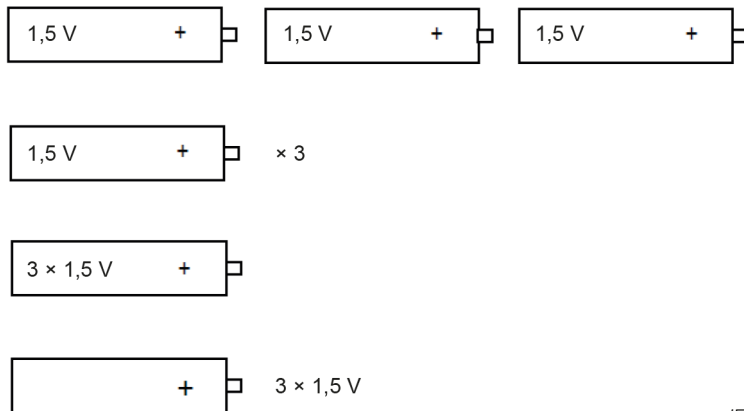

IEC

W.3.5 Luminaires with non-standardized replaceable rechargeable battery

Luminaires using non-standardized replaceable rechargeable batteries shall be marked with the technology, for example NiCd, the rated capacity (in mAh or Ah) and voltage of the battery. The marking shall be in accordance with 6.2, item a).

In addition, the instruction shall provide a warning that the battery may only be replaced by the battery provided or indicated by the luminaire manufacturer.

In the case of batteries that are provided with mechanical keys that prevent the use of other types of batteries from other manufacturers, the above information is not required.

W.3.6 Luminaires with non-user replaceable battery/EDLC

Luminaires using non-user replaceable batteries shall be marked with the technology, for example NiCd, the rated capacity (in mAh or Ah) and voltage of the battery. The marking shall be in accordance with 6.2, item a).

Luminaires using a non-user replaceable battery/EDLC shall carry the substance of the following sentence and the following information in the instructions:

"The battery/EDLC contained in this luminaire shall only be replaced by the manufacturer or their service agent or a similarly skilled person".

If the manufacturer indicates that the battery or EDLC is only replaceable with a specific type, the type reference or the code of the replaceable battery or EDLC shall be provided. If the battery or EDLC is replaceable with another type, the following additional details shall be provided:

- type of battery or EDLC (according to the applicable IEC standard);
- temperature rating or classification;
- dimensions.

Luminaires with a non-user replaceable battery or EDLC, where, after opening for battery or EDLC replacement, give access to hazardous live parts, shall be marked with the following "Caution, electric shock risk" warning symbol:

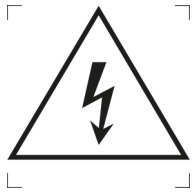

Caution, electric shock risk (SOURCE: IEC 60417-6042:2010-11)

The minimum height of this symbol shall be 15 mm.

W.3.7 Luminaires with non-replaceable battery/EDLC

Luminaires using a non-replaceable battery/EDLC shall carry the substance of the following sentence in the instructions:

"The battery/EDLC of this luminaire is not replaceable; when the battery/EDLC reaches its end of life the whole luminaire shall be taken out of service".

W.3.8 Luminaires supplied by external dedicated power supply units

For luminaires intended to be supplied from a dedicated detachable supply unit for the purposes of recharging, the battery/EDLC shall be marked with the symbol IEC 60417-6181:2016-01 and its type reference along with the symbol ISO 7000-0790:2004-01 or with the substance of the following:

"Use only with <model designation> supply unit".

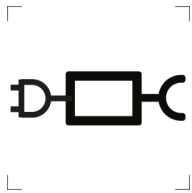

Separate supply unit (SOURCE: IEC 60417-6181:2016-01)

If the symbol IEC 60417-6181:2016-01 is used, the type reference of the detachable supply unit shall be placed in close proximity to the symbol. The instructions shall give the substance of the following information:

"Do not use any charger other than the one provided specifically for use with the device".

W.3.9 Rechargeable luminaires other than ordinary

For battery/EDLC-operated other than ordinary luminaires to be recharged with an external charger, where the IP degree cannot be maintained during the charge operation, shall be provided with instructions stating that the electrical connection during the charging operation shall be done indoors.

W.3.10 Conditions for charging

Instructions regarding battery charging and the ambient temperature range for the charging system during charging shall be provided.

W.4 Construction

W.4.1 General

For battery/EDLC-operated luminaires with a replaceable battery/EDLC, the battery or EDLC compartment shall be designed to reduce the possibility of children removing the battery by one of the following means:

- a tool, such as a screwdriver or coin, is required to open the battery compartment; or
- the battery compartment door or cover requires the application of a minimum of two independent and simultaneous movements to open by hand.

For battery/EDLC-operated luminaires with a non-replaceable battery/EDLC, it shall not be possible to gain access to the battery or EDLC without breaking the luminaire or its parts.

Battery/EDLC-operated luminaires with replaceable batteries, where non-rechargeable and rechargeable batteries having the same dimension and shape can be available, shall not provide a recharging function.

W.4.2 Small batteries (coins, button and other non-standardized batteries)

Batteries that fit wholly within the small parts cylinder as specified in ISO 8124-1:2022, 5.2 shall not be removable without the aid of a tool.

NOTE The types and dimensions of batteries are specified in IEC 60086-2.

For parts of luminaires that contain batteries, if the part fits wholly within the small parts cylinder as specified in ISO 8124-1:2022, 5.2, the part shall not be removable without the aid of a tool.

Compliance is checked by inspection and by the following test.

A force is applied to the part under consideration without jerks for 10 s in the most unfavourable direction. The force is as follows:

- *push force, 50 N;*
- *pull force:*
 - *if the shape of the part is such that the fingertips cannot easily slip off, 50 N;*
 - *if the projection of the part that is gripped is less than 10 mm in the direction of removal, 30 N.*

The push force is applied by test probe 11 of IEC 61032. The pull force is applied by a suitable means, such as a suction cup, so that the test results are not affected. While the force is being applied, the test fingernail of IEC 60335-1:2020, Figure 7, is inserted in any aperture or joint with a force of 10 N. The fingernail is then slid sideways with a force of 10 N but is not twisted or used as a lever.

If the shape of the part is such that an axial pull is unlikely, the pull force is not applied but the test fingernail is inserted in any aperture or joint with a force of 10 N and is then pulled for 10 s by means of the loop with a force of 30 N in the direction of removal.

If the part is likely to be twisted, the following torque is applied at the same time as the pull or push force:

- *2 Nm, for major dimensions up to and including 50 mm;*
- *4 Nm, for major dimensions over 50 mm.*

This torque is also applied when the test fingernail is pulled by means of the loop. If the projection of the part which is gripped is less than 10 mm, the torque is reduced by 50 %.

The part shall not become detached.

The battery compartment shall have adequate mechanical strength.

Compliance is checked by the following test.

The luminaire is placed on a horizontal steel surface. A cylindrical metallic mass of 1 kg, having a diameter of 80 mm, is dropped from a height of 100 mm so that its flat face falls onto the luminaire. The test is carried out once with the cylindrical metallic mass striking the luminaire in the most unfavourable place.

The battery compartment shall not become open.

W.4.3 Battery compartment fasteners for small batteries and other standardized batteries (e.g. AAA or AA)

If screws or similar fasteners are used to secure a door or cover providing access to the battery compartment, the screw or similar fastener shall be captive to ensure that they remain with the door, cover or equipment.

Compliance is checked by inspection and by the following test after the battery door or cover is opened.

A force of 20 N is applied to the screw or similar fastener without jerks for a duration of 10 s in any direction.

The screw or similar fastener shall not become separated from the door, cover or equipment.

W.4.4 Battery/EDLC chargers incorporated in luminaires

Electronic circuits used in battery/EDLC chargers within the luminaire shall comply with IEC 61347-2-11.

If the battery/EDLC can be charged in the luminaire, and if the luminaire can be operated while the batteries are being charged, the battery/EDLC charger is also considered to be a controlgear, and shall comply with the applicable controlgear standard dependent on the light source (e.g. IEC 61347-2-13 for controlgear for LED modules).

W.4.5 Short-circuit protection

The battery/EDLC-operated luminaire and any cords except supply cords, as appropriate, are tested with the battery connected, under the following fault conditions applied one at a time:

- any cord provided between the battery/EDLC-operated luminaire and a separable battery/EDLC shall be short-circuited at the point along its length likely to produce the most adverse effects;
- for luminaires with batteries/EDLCs that are replaceable and that can be removed without the aid of a tool, and with terminals that can be short-circuited by a thin straight bar, the terminals of the battery are short-circuited;
- charging terminals of the battery/EDLC-operated luminaire that are simultaneously accessible with the test probe 13 of IEC 61032 are short-circuited so as to produce the most unfavourable result.

The battery/EDLC-operated luminaire is switched on and no additional mechanical load is applied. The tests are conducted until the test sample achieves a steady condition, including returning to room temperature or, until a time period of at least 3 h has elapsed. The resistance of the short-circuit shall not exceed 10 mΩ. In this case, 7.26 is not applicable.

During the tests, the appliance shall not emit flames, molten metal, or ignitable gas in hazardous amount. No explosion or ignition of the battery shall occur during or after the test. Venting of the cells is permitted provided that they have not vented by any means other than through their vents.

W.4.6 Electrical parameters of the batteries operation

W.4.6.1 General conditions for testing lithium-ion battery charging

Measurements of cell voltages during the tests of lithium-ion systems shall be made using a single pole resistive-capacitive low pass filter with a cut-off frequency of $5 \text{ KHz} \pm 500 \text{ Hz}$. If charging voltage limits have been exceeded, the peak value of the voltage measured after this network shall be used. The measurement shall have a tolerance within $\pm 1 \%$.

The location of thermocouples for lithium-ion cell temperature measurements shall be on the outer surface, half way along the longest dimension, of the cell that results in the highest temperature.

Currents measured during battery charging shall be average currents with an averaging period of 1 s to 5 s.

When a battery comprising a single cell is employed, instructions in this document referring to special preparations of a cell in a series configuration shall be ignored.

For battery designs where there is a series arrangement of parallel clusters of cells, the cluster shall be treated as a single cell for those tests that require altering the amount of charge on a single cell prior to conducting the test.

This document does not apply to luminaires that are intended to charge general purpose cells or batteries installed by the user.

W.4.6.2 Normal charging of lithium-ion systems

Charging a lithium-ion battery under normal conditions shall not exceed the specified operating region for charging of the cell.

Compliance is checked by the following tests.

The battery is charged in accordance with the charging system instructions starting with a discharged battery (level where the light source extinguishes). Testing is carried out at an ambient temperature of $(20 \pm 5) \text{ }^\circ\text{C}$ and

- if the battery-operated luminaire is recommended to be charged at a minimum temperature lower than $4 \text{ }^\circ\text{C}$, the test is also conducted at that minimum temperature with a tolerance of $-\overset{0}{5} \text{ }^\circ\text{C}$;*
- if the battery-operated luminaire is recommended to be charged at a maximum temperature greater than $40 \text{ }^\circ\text{C}$, the test is also conducted at that maximum temperature with a tolerance of $+\overset{5}{0} \text{ }^\circ\text{C}$.*

For all individual cells, the voltage, the temperature measured in accordance with W.4.6.1 and the charging current are monitored. In the case of parallel configurations, analysis may be used to avoid measuring the individual branch currents. The result shall not exceed their specified operating region for charging (e.g. limits of voltage and current dependent on the temperature).

NOTE 1 The following is an example result of such analysis: the charging current for each branch of a parallel connection does not require monitoring, if the maximum deliverable current of the charger did not exceed the maximum charging current of a single cell.

For batteries employing series configurations, the test is repeated with a deliberately imbalanced battery. The imbalance is introduced into a discharged battery by charging one cell to approximately 50 % of full charge.

If it can be demonstrated through testing or by design evaluation that an imbalance less than 50 % would actually occur in normal use, then this lower imbalance may be used.

NOTE 2 Examples are those designs that employ circuitry intended for maintaining a balance between cells in the battery pack. Systems with a small number of cells in series can be shown to exhibit limited imbalance in practice, if the product ceases to operate with a battery prepared with a smaller initial imbalance.

NOTE 3 An example for a testing is repeated charging and discharging a battery in accordance with the manufacturer's instructions until its capacity has decreased to 80 % of the rated capacity, using the imbalance at the end of the test.

W.4.7 Protection against overpressure for Li-ion batteries used in luminaires

The enclosure or compartment of a battery-operated luminaire that contains a battery that uses Li-ion chemistry with a single cell capacity of 0,2 Ah or greater, shall withstand the pressure generated when a cell vents during failure.

Compliance is checked by inspection and measurement in the case of a) or by the test of b).

- a) The total area of the unobstructed openings in the enclosure allowing gasses to pass shall be not less than the value specified in Table W.2; or
- b) a volume of air of the amount specified in Table W.3 shall be injected through a (2,85 ± 0,05) mm diameter orifice into the enclosure at an initial overpressure of 2 070 kPa with a tolerance of ±10 %. Test fittings used for the test shall not increase the enclosure volume by more than 3 ml. The overpressure within the enclosure shall drop below 70 kPa within 30 s without any unintended rupturing damage to the enclosure

Table W.2 – Total area of openings for Li-ion cells

Capacity of the single Li-ion cell with the highest capacity Ah	Minimum total area of openings mm ²
0,2 ≤ Ah < 5	20
5 ≤ Ah < 25	30
25 ≤ Ah < 100	50
Ah ≥ 100	100

Table W.3 – Volume of air injected at 2 070 kPa

Capacity of the single Li-ion cell with the highest capacity Ah	Volume of air (±10 %) ml
0,2 ≤ Ah < 5	20
5 ≤ Ah < 25	30
25 ≤ Ah < 100	50
Ah ≥ 100	100

W.4.8 Protection against the consequence of failure of cells or EDLCs

Vents of cells shall not be obstructed in such a way as to defeat their operation if venting is relied upon for compliance with this document.

Space shall be provided to allow EDLC expansion during the failure mode.

Compliance is checked by inspection.

W.5 Protection against electric shock

Battery/EDLC-operated luminaires using a replaceable battery/EDLC, shall be so constructed that their hazardous live parts are not accessible when the luminaire is opened as necessary for replacing batteries, even if the operation cannot be achieved by hand.

If hazardous live parts are accessible when the luminaire is opened as necessary for replacing non-user replaceable batteries or EDLCs, a protective cover shall be provided requiring the use of a tool for its removal. The cover shall be marked according to W.3.6.

W.6 Endurance test and thermal test

W.6.1 Endurance test

For battery/EDLC-operated luminaires with charging function of the batteries or EDLCs, the endurance test shall be as specified in 14.3.2 except that the requirements of items c) and d) shall be replaced by the following:

The luminaire shall be tested in the enclosure for a total duration of 390 h, made up of 10 successive cycles of 36 h and a final normal operation for 30 h, at maximum rated supply voltage (range). The luminaire shall be operated normally from maximum supply voltage (range) for 30 h and for 6 h supplied by the battery/EDLC, in each of the 10 cycles. In the case of durations longer than 6 h, the operating period shall be extended until the light source extinguishes and the total duration shall be increased accordingly. In the case of a duration longer than 10 h, the discharge duration may be limited to 10 h, in this case the batteries shall be replaced after each cycle with discharged batteries.

For battery/EDLC-operated luminaires without charging function, the endurance test shall be as specified in 14.3.2 except that the requirements of items c) and d) shall be replaced by the following:

The luminaire shall be tested in the enclosure for a total duration of 240 h without interruption.

The luminaire is supplied by the battery/EDLC. If the duration of the battery/EDLC is not sufficient to last the duration of the endurance test, it is possible to replace the battery/EDLC to reach the total hours of the endurance test, or it is possible to replace the battery/EDLC with suitable external power supply providing the same electrical parameters. In this last case the battery/EDLC shall be electrically disconnected from the circuit, but kept in place in the luminaire.

Compliance is checked by the requirements of 14.3.3.

W.6.2 Thermal test (normal operation)

For battery/EDLC-operated luminaires, the temperature measured on the surface of batteries or EDLCs shall not exceed the specified values.

The thermal tests given in 14.4 shall be carried out in both the charging mode and battery/EDLC operating mode.

If during the charging mode, it is possible to operate the light source, the test in the charging mode shall be carried out in this condition.

During the charging mode, the surface temperatures shall be monitored starting from a discharged battery/ EDLC (level where the light source extinguishes), during the charging phase and where the battery is completely charged for a period suitable to reach the steady state conditions, unless otherwise specified below.

The following temperature limits are applicable, unless otherwise specified by the battery manufacturer. The location of the thermocouples for cell temperature measurements shall be on the outer surface, half way along the longest dimension, of the cell that results in the highest temperature. It is important to determine the position of the maximum surface temperature of the battery, particularly with respect to multi-cell battery packs.

The position of the hottest point of the battery shall be detected. The temperature of the battery pack in the luminaire shall be assessed, whilst the luminaire is charging, to confirm the position of the hottest point on the battery pack. The hottest point of the battery pack when installed within a luminaire, when supplied as a controlgear component, may be different to that already specified on the battery pack.

- a) For sealed nickel cadmium batteries, the maximum surface temperature of the battery shall be:
 - i) 40 °C for designated T type cells;
 - ii) 50 °C for designated U type cells.

The maximum surface temperature of the battery within the luminaire shall be measured after 48 h from the start of recharge.

- b) For sealed nickel metal-hydride batteries, the maximum surface temperature of the battery shall be:
 - i) 40 °C for designated T type cells;
 - ii) 50 °C for designated U type cells.

The maximum surface temperature of the battery within the luminaire shall be measured after 48 h from the start of recharge.

- c) For valve regulated lead acid batteries, the maximum surface temperature of the battery shall be:
 - i) 30 °C with temperature compensation of float charge voltage normally between $-3 \text{ mV/cell/}^\circ\text{C}$ and $-4 \text{ mV/cell/}^\circ\text{C}$ or as recommended by the cell manufacturer, or
 - ii) 25 °C without temperature compensation, the float charge voltage at 25 °C shall be between 2,22 V/cell and 2,4 V/cell as recommended by the cell manufacturer.

The surface temperature of the battery is measured continuously from the start of charge for a period of 48 h and at no time the temperature shall exceed limits.

- d) For Li batteries, the temperature of the hottest point shall comply with the temperature limit as specified by the battery manufacturer.

The surface temperature of the battery is measured continuously from the start of charge for a period of 48 h and at no time the temperature shall exceed limits.

W.6.3 Thermal test (abnormal operation)

Battery/EDLC-operated luminaires shall be tested according to 14.5, but with additional abnormal operating conditions.

- For battery/EDLC-operated luminaires with charging function, the batteries or EDLCs shall be replaced by a short-circuit link.
- Battery-operated luminaires with replaceable batteries are supplied at rated voltage in charge mode and under normal operating conditions in discharge mode, but with one battery removed or inserted in the battery compartment with the polarity reversed, if it is possible by the construction. This requirement is not applicable to non-user replaceable batteries.

NOTE This last bullet is used to simulate the case where there are batteries in series and one of the batteries is inserted with the wrong polarity. This will lead to a situation where the batteries (in right polarity) will charge the battery in the wrong polarity. If the batteries are fully charged, this can lead to an overheating of the batteries.

Compliance is checked by the tests as required in 14.5.2 with the above addition.

During the tests, the battery/EDLC-operated luminaires shall comply with 14.5.3 and shall not become unsafe.

The temperature rise of surfaces of accessible batteries shall not exceed 45 K. The temperature rise of non-accessible batteries shall not exceed 60 K.

W.6.4 Lithium-ion charging systems – Fault conditions

This Subclause W.6.4 applies only to luminaires using lithium-ion batteries.

The charging system and battery of a lithium-ion system shall be so designed that the risk of fire and explosion as a result of a fault condition during charging is obviated as far as is practical.

Compliance is checked by the following test.

A sample containing the battery and the associated assemblies of the charging system are placed on a soft wood surface covered by two layers of tissue paper (as defined in ISO 4046-4:2016, 4.187); the sample is covered by one layer of untreated 100 % cotton medical gauze. The luminaire is charged in accordance with the user instruction manual with all of the categories of fault conditions listed below in a) to c).

- a) *Electronic components in the charging system of the luminaire are subjected to the fault condition test according to IEC 61347-1:2015, Clause 14 and IEC 61347-1:2015/AMD1:2017, Clause 14, if the outcome of such a fault is uncertain based upon analysis. For each fault condition introduced, the state of the battery before charging is as follows:*
 - *a series configured battery shall have a deliberate imbalance. The imbalance is introduced into a discharged battery (level where the light source extinguishes) by charging one cell to approximately 50 % of full charge; or*
 - *if the test of W.4.6.2 is conducted with an imbalance of less than 50 %, a series configured battery shall have a deliberate imbalance as established in W.4.6.2; or*
 - *a single cell or parallel only configuration battery shall be discharged (level where the light source extinguishes).*
- b) *If the test of W.4.6.2 is conducted with an imbalance of less than 50 % due to the function of circuit(s), and if a single fault of any component within that circuit(s) is shown to result in the loss of that function, then a series configured battery shall be charged with a deliberate imbalance. The imbalance is introduced into a discharged battery by charging one cell to approximately 50 % of full charge.*
- c) *For a battery with a series configuration, all cells are at approximately 50 % charge, except for one which is shorted. The battery is then charged.*

During the tests, each cell voltage is continuously monitored. Venting of the cells is permitted.

The test is conducted until the sample under test experiences a failure or returns to within 5 K of the ambient temperature or, if neither of these, until at least 7 h or twice the normal charge period has elapsed, whichever is longer.

Tests are considered passed if all of the following are true:

- There has been no explosion during the test.
- No charring or burning of the gauze or tissue paper has resulted. Charring is defined as a blackening of the gauze caused by combustion. Discoloration of the gauze caused by smoke is acceptable. Charring or igniting of the tissue paper or gauze from the shorting means is not considered a failure.
- The cells shall not have exceeded the upper limit charging voltage by more than 150 mV or, if they have, then the charging system shall be permanently disabled from recharging the battery. To determine if recharging is disabled, the battery shall be discharged by using the battery-operated luminaire tested (in the case of an integral system) or by using a new sample of the battery-operated luminaire (in the case of a detachable battery pack system) to approximately 50 % charge, followed by an attempt to recharge the battery normally. There shall be no charging current after 10 min or after 25 % of the nominal capacity has been delivered, whichever occurs first.
- There shall be no evidence of damage to any cell vent.
- Hazardous live parts shall not become accessible to the standard test finger (IEC 61032 test probe B).

IECNORM.COM : Click to view the full PDF of IEC 60598-1:2024

Bibliography

IEC 60050-151, *International Electrotechnical Vocabulary (IEV) – Part 151: Electrical and magnetic devices*, available at <https://www.electropedia.org>

IEC 60050-195, *International Electrotechnical Vocabulary (IEV) – Part 195: Earthing and protection against electric shock*, available at <https://www.electropedia.org>

IEC 60050-482, *International Electrotechnical Vocabulary (IEV) – Part 482: Primary and secondary cells and batteries*, available at <https://www.electropedia.org>

IEC 60050-845, *International Electrotechnical Vocabulary (IEV) – Part 845: Lighting*, available at <https://www.electropedia.org>

IEC 60061 (all parts), *Lamp caps and holders together with gauges for the control of interchangeability and safety*, available at <http://std.iec.ch/iec60061>

IEC 60068-2-2:2007, *Environmental testing – Part 2-2: Tests – Test B: Dry heat*

IEC 60079 (all parts), *Explosive atmospheres*

IEC 60081, *Double-capped fluorescent lamps – Performance specifications*

IEC 60086-1, *Primary batteries – Part 1: General*

IEC 60086-2, *Primary batteries – Part 2: Physical and electrical specifications*

IEC 60216 (all parts), *Electrical insulating materials – Thermal endurance properties*

IEC 60228, *Conductors of insulated cables*

IEC 60269 (all parts), *Low-voltage fuses*

IEC 60357, *Tungsten halogen lamps (non-vehicle) – Performance specifications*

IEC 60364 (all parts), *Low-voltage electrical installations*

IEC 60364-4-41, *Low-voltage electrical installations – Part 4-41: Protection for safety – Protection against electric shock*

IEC 60364-4-443⁶, *Electrical installations of buildings – Part 4: Protection for safety – Chapter 44: Protection against overvoltages – Section 443: Protection against overvoltages of atmospheric origin or due to switching*

IEC 60364-5-51, *Electrical installations of buildings – Part 5-51: Selection and erection of electrical equipment – Common rules*

IEC 60364-5-54:2011, *Low-voltage electrical installations – Part 5-54: Selection and erection of electrical equipment – Earthing arrangements and protective conductors*

⁶ Withdrawn.

IEC 60364-7-701, *Low-voltage electrical installations – Part 7-701: Requirements for special installations or locations – Locations containing a bath or shower*

IEC 60364-7-702, *Low-voltage electrical installations – Part 7-702: Requirements for special installations or locations – Swimming pools and fountains*

IEC 60400, *Lampholders for tubular fluorescent lamps and starterholders*

IEC 60432-3, *Incandescent lamps – Safety specifications – Part 3: Tungsten halogen lamps (non-vehicle)*

IEC 60449, *Voltage bands for electrical installations of buildings⁷*

IEC 60598-2-2, *Luminaires – Part 2-2: Particular requirements – Recessed luminaires and recessed air-handling luminaires*

IEC 60598-2-3, *Luminaires – Part 2-3: Particular requirements – Luminaires for road and street lighting*

IEC 60598-2-5, *Luminaires – Part 2-5: Particular requirements – Floodlights*

IEC 60664 (all parts), *Insulation coordination for equipment within low-voltage systems*

IEC 60664-1:2020, *Insulation coordination for equipment within low-voltage systems – Part 1: Principles, requirements and tests*

IEC 60664-3, *Insulation coordination for equipment within low-voltage systems – Part 3: Use of coating, potting or moulding for protection against pollution*

IEC 60682, *Standard method of measuring the pinch temperature of quartz-tungsten-halogen lamps*

IEC 60695 (all parts), *Fire hazard testing*

IEC TS 60695-1-14, *Fire hazard testing – Part 1-14: Guidance on the different levels of power and energy related to the probability of ignition and fire in low voltage electrotechnical products*

IEC 60695-2 (all parts), *Fire hazard testing – Part 2: Glowing/hot-wire based test methods*

IEC 60838 (all parts), *Miscellaneous lampholders*

IEC 60901, *Single-capped fluorescent lamps – Performance specifications*

IEC 60921, *Ballasts for tubular fluorescent lamps – Performance requirements*

IEC 60923, *Auxiliaries for lamps – Ballasts for discharge lamps (excluding tubular fluorescent lamps) – Performance requirements*

IEC 60929, *AC and/or DC-supplied electronic control gear for tubular fluorescent lamps – Performance requirements*

⁷ Withdrawn.

IEC 60950-1:2005⁸, *Information technology equipment – Safety – Part 1: General requirements*

IEC 61140:2016, *Protection against electric shock – Common aspects for installation and equipment*

IEC 61156 (all parts), *Multicore and symmetrical pair/quad cables for digital communications*

IEC 61184, *Bayonet lampholders*

IEC 61195, *Double-capped fluorescent lamps – Safety specifications*

IEC 61199:2011, *Single-capped fluorescent lamps – Safety specifications*

IEC 61199:2011/AMD1:2012

IEC 61199:2011/AMD2:2014

IEC 61210, *Connecting devices – Flat quick-connect terminations for electrical copper conductors – Safety requirements*

IEC 61558-2-5, *Safety of transformers, reactors, power supply units and combinations thereof – Part 2-5: Particular requirements and test for transformer for shavers, power supply units for shavers and shaver supply units*

IEC 61995 (all parts), *Devices for the connection of luminaires for household and similar purposes*

IEC 62031, *LED modules for general lighting – Safety specifications*

IEC 62035, *Discharge lamps (excluding fluorescent lamps) – Safety specifications*

IEC 62133-1, *Secondary cells and batteries containing alkaline or other non-acid electrolytes – Safety requirements for portable sealed secondary cells, and for batteries made from them, for use in portable applications – Part 1: Nickel systems*

IEC 62368 (all parts), *Audio/video, information and communication technology equipment*

IEC 62368-3:2017, *Audio/video, information and communication technology equipment – Part 3: Safety aspects for DC power transfer through communication cables and ports*

IEC 62471:2006, *Photobiological safety of lamps and lamp systems*

IEC TR 62471-2:2009⁹, *Photobiological safety of lamps and lamp systems – Part 2: Guidance on manufacturing requirements relating to non-laser optical radiation safety*

IEC 62504:2014, *General lighting – Light emitting diode (LED) products and related equipment – Terms and definitions*

IEC 62722 (all parts), *Luminaire performance*

IEC TR 63139, *Explanation of the mathematical addition of working voltages, insulation between circuits and use of PELV in TC 34 standards*

⁸ Withdrawn.

⁹ Withdrawn.

ISO/IEC 11801 (all parts), *Information technology – Generic cabling for customer premises*

ISO 48-4:2018, *Rubber, vulcanized or thermoplastic – Determination of hardness – Part 4: Indentation hardness by durometer method (Shore hardness)*

ISO 4046-4:2016, *Paper, board, pulp and related terms – Vocabulary – Part 4: Paper and board grades and converted products*

ISO 16893, *Wood-based panels – Particleboard*

ANSI C136 Series, *American National Standards for Roadway and Area Lighting Equipment*

AS 3771, *Road lighting luminaires with integral control gear*

IEEE 802.3, *IEEE Standard for Ethernet*

KOUWENHOVEN, W.B., HOOKER, D.R. and LOTZ, E.L. *Electric Shock Effects of Frequency*. 1936

IECNORM.COM : Click to view the full PDF of IEC 60598-1:2024

[IECNORM.COM](https://www.iecnorm.com) : Click to view the full PDF of IEC 60598-1:2024

SOMMAIRE

AVANT-PROPOS	263
INTRODUCTION.....	266
1 Domaine d'application	267
2 Références normatives	267
3 Termes et définitions	271
4 Exigences générales	296
4.1 Généralités	296
4.2 Exigences d'essai générales et vérification	296
4.3 Éléments constitutifs des luminaires	298
4.4 Informations relatives à la conception des luminaires dans les normes relatives aux sources de lumière et aux appareillages de commande.....	299
5 Classification des luminaires	299
5.1 Généralités	299
5.2 Classification en fonction du type de protection contre les chocs électriques	299
5.3 Classification en fonction du degré de protection contre la pénétration des poussières, des corps solides et de l'humidité.....	300
5.4 Classification selon le matériau de la surface de montage pour laquelle le luminaire est conçu.....	300
5.5 Classification selon les conditions d'emploi.....	300
6 Marquage	300
6.1 Généralités	300
6.2 Marquage sur les luminaires	301
6.3 Informations à marquer sur les luminaires.....	303
6.4 Renseignements complémentaires.....	313
6.5 Essai de marquage	318
7 Construction	319
7.1 Généralités	319
7.2 Composants remplaçables	319
7.3 Passages de fils.....	319
7.4 Douilles	319
7.5 Douilles de starter.....	321
7.6 Blocs de jonction	321
7.7 Bornes et raccordement au réseau	322
7.8 Interrupteurs	324
7.9 Recouvrements et manchons isolants	325
7.10 Double isolation et isolation renforcée	326
7.11 Connexions électriques et parties conductrices.....	328
7.12 Vis, connexions (mécaniques) et presse-étoupes.....	330
7.13 Résistance mécanique	333
7.14 Suspensions, fixations et appareils de réglage.....	336
7.15 Matériaux inflammables	340
7.16 Luminaires pour installation sur des surfaces normalement inflammables	341
7.17 Trous de vidange	343
7.18 Résistance à la corrosion.....	343
7.19 Amorceurs	344
7.20 Luminaires pour conditions sévères d'emploi	344
7.21 Écran de protection.....	346

7.22	Accessoires fixés aux lampes	347
7.23	Semi-luminaires	347
7.24	Dangers photobiologiques.....	347
7.24.1	Dangers actiniques des UV pour la peau et l'œil (200 nm à 400 nm).....	347
7.24.2	Danger des UV-A pour le cristallin de l'œil (315 nm à 400 nm)	348
7.24.3	Danger rétinien lié à la lumière bleue.....	348
7.24.4	Danger thermique pour la rétine (380 nm à 1 400 nm)	349
7.24.5	Danger des infrarouges pour l'œil (780 nm à 3 000 nm).....	350
7.24.6	Danger thermique pour la peau (380 nm à 3 000 nm)	350
7.25	Dangers mécaniques	350
7.26	Protection contre les courts-circuits	350
7.27	Bloc de jonction avec contacts automatiques de terre de protection intégrés	351
7.28	Fixation des appareils de contrôle sensibles à la température.....	351
7.29	Luminaires avec sources de lumière non remplaçables	352
7.30	Luminaires avec sources de lumière non remplaçables par l'utilisateur et composants non remplaçables par l'utilisateur final.....	352
7.31	Isolation entre les circuits	353
7.31.1	Généralités	353
7.31.2	Circuits TBTS ou TBTP.....	353
7.31.3	Circuits TBTF	354
7.31.4	Autres circuits.....	355
7.31.5	Exigences supplémentaires pour les luminaires qui utilisent des appareillages commandables qui fournissent une ou plusieurs sorties TBTS	355
7.32	Appareils de protection contre les surtensions externes aux appareillages de commande	356
7.32.1	Généralités	356
7.32.2	Dispositifs de protection contre les surtensions (SPD)	356
7.32.3	Composants de protection contre les surtensions (SPC).....	356
7.33	Luminaire alimenté par le biais d'un câblage de communication informatique.....	358
7.34	Champs électromagnétiques (EMF)	359
7.35	Protection contre les pales de ventilateur en mouvement.....	359
7.36	Luminaires montés sur rail	359
8	Câblage externe et interne	359
8.1	Généralités	359
8.2	Raccordement au réseau et autres câblages externes	360
8.3	Câblage interne	368
8.4	Essai pour déterminer l'adéquation des conducteurs ayant une section transversale réduite	371
9	Dispositions en vue de la mise à la terre	372
9.1	Généralités	372
9.2	Dispositions en vue de la mise à la terre.....	372
10	Protection contre les chocs électriques.....	375
10.1	Généralités	375
10.2	Protection contre les chocs électriques	375
11	Résistance à la poussière, aux corps solides et à l'humidité	380
11.1	Généralités	380
11.2	Conditions générales et essais pour la classification IP	380
11.2.1	Généralités	380

11.2.2	Essais pour les premiers chiffres 2, 3 et 4 de la caractéristique IP.....	382
11.2.3	Essais pour les premiers chiffres 5 et 6 de la caractéristique IP.....	382
11.2.4	Luminaires protégés contre les chutes d'eau verticales – Essais pour le deuxième chiffre 1 de la caractéristique IP	383
11.2.5	Luminaires protégés contre les chutes d'eau verticales – Essais pour le deuxième chiffre 2 de la caractéristique IP	384
11.2.6	Luminaires protégés contre la pluie – Essais pour le deuxième chiffre 3 de la caractéristique IP	384
11.2.7	Luminaires protégés contre les projections d'eau – Essais pour le deuxième chiffre 4 de la caractéristique IP	385
11.2.8	Luminaires protégés contre les jets d'eau – Essais pour le deuxième chiffre 5 de la caractéristique IP	385
11.2.9	Luminaires protégés contre les jets d'eau puissants – Essais pour le deuxième chiffre 6 de la caractéristique IP	386
11.2.10	Luminaires étanches à l'immersion – Essais pour le deuxième chiffre 7 de la caractéristique IP	387
11.2.11	Luminaires étanches à l'immersion sous pression – Essais pour le deuxième chiffre 8 de la caractéristique IP	387
11.2.12	Luminaires protégés contre les jets d'eau à haute pression et haute température –Essais pour le deuxième chiffre 9 (80 °C) de la caractéristique IP.....	387
11.2.13	Luminaires protégés contre les jets d'eau froide à haute pression – Essais pour le deuxième chiffre 9 (15 °C) de la caractéristique IP	387
11.3	Essai d'humidité.....	387
12	Résistance d'isolement, rigidité diélectrique, courant de contact et courant dans le conducteur de protection	388
12.1	Généralités	388
12.2	Résistance d'isolement et rigidité diélectrique	388
12.2.1	Généralités	388
12.2.2	Essai – Résistance d'isolement.....	389
12.2.3	Essai – Rigidité diélectrique.....	391
12.3	Courant de contact, courant dans le conducteur de protection et brûlure électrique.....	393
13	Lignes de fuite et distances dans l'air	394
13.1	Généralités	394
13.2	Exigences	395
13.2.1	Généralités	395
13.2.2	Lignes de fuite	396
13.2.3	Distances dans l'air	397
14	Essai d'endurance et essai d'échauffement	399
14.1	Généralités	399
14.2	Sélection des lampes et appareillages de commande	399
14.3	Essai d'endurance	400
14.3.1	Généralités	400
14.3.2	Essai	400
14.3.3	Conformité.....	402
14.4	Essai d'échauffement (fonctionnement normal)	402
14.4.1	Généralités	402
14.4.2	Essai	402
14.4.3	Conformité.....	404
14.5	Essai d'échauffement (fonctionnement anormal)	408

14.5.1	Généralités	408
14.5.2	Essai	409
14.5.3	Conformité	410
14.6	Essai d'échauffement (concerne la défaillance des enroulements des appareillages de commande)	413
14.6.1	Généralités	413
14.6.2	Essai pour les luminaires sans coupe-circuit thermiques	413
14.6.3	Essai pour les luminaires avec appareils de contrôle sensibles à la température	414
14.7	Essai d'échauffement en rapport avec des conditions défectueuses des appareillages de commande ou des dispositifs électroniques incorporés dans des luminaires en matière thermoplastique	415
14.7.1	Généralités	415
14.7.2	Essai pour les luminaires sans appareils de contrôle sensibles à la température	415
14.7.3	Essai pour les luminaires équipés d'appareils de contrôle sensibles à la température, internes ou externes à l'appareillage de commande ou au transformateur	418
15	Résistance à la chaleur, au feu et aux courants de cheminement	419
15.1	Généralités	419
15.2	Résistance à la chaleur	419
15.3	Résistance à la flamme et à l'inflammation	420
15.4	Résistance aux courants de cheminement	420
16	Bornes à serrage sous tête de vis	421
16.1	Généralités	421
16.2	Exigences générales et principes fondamentaux	427
16.3	Exigences et essais mécaniques	430
17	Bornes sans vis et connexions électriques	433
17.1	Généralités	433
17.2	Exigences générales	435
17.3	Instructions générales pour les essais	437
17.3.1	Préparation des échantillons	437
17.3.2	Conducteurs d'essai	437
17.3.3	Bornes multiconducteurs	437
17.3.4	Bornes multivoies	437
17.3.5	Quantités à soumettre à l'essai	437
17.4	Bornes et connexions pour câblage interne	437
17.4.1	Essais mécaniques	437
17.4.2	Essais électriques	438
17.5	Bornes et connexions pour câblage externe	440
17.5.1	Conducteurs	440
17.5.2	Essais mécaniques	440
17.5.3	Essais électriques	441
Annexe A (normative)	Essai destiné à déterminer si une partie conductrice peut provoquer un choc électrique	443
A.1	Généralités	443
A.2	Limites de tension de contact	443
A.3	Limites de courant de contact	443
A.4	Conformité	443
Annexe B (normative)	Lampes d'essai	444

B.1	Généralités	444
B.2	Lampes à filament du domaine d'application de l'IEC 60432-1 et l'IEC 60432-2	444
B.2.1	Principaux modes de transfert de chaleur et lampes utilisées pour les essais	444
B.2.2	Lampes à filament d'essai	445
B.3	Lampes halogènes du domaine d'application de l'IEC 60432-3	446
B.4	Lampes tubulaires à fluorescence et autres lampes à décharge	446
B.5	Modules à LED du domaine d'application de l'IEC 62031	447
Annexe C (normative)	Conditions de circuit anormales	448
Annexe D (normative)	Essais d'échauffement	451
D.1	Enceinte à air calme	451
D.2	Surface de montage	451
D.3	Autre procédure d'essai pour le réglage des températures mesurées pour la ou les t_a assignées du luminaire	452
D.3.1	Généralités	452
D.3.2	Essai d'échauffement en fonctionnement normal de luminaires sans appareils de contrôle sensibles à la température et lorsque la température ambiante assignée t_a marquée sur le luminaire est supérieure à la température ambiante à l'intérieur de l'enceinte à air calme	452
Annexe E (normative)	Détermination des échauffements des enroulements par la méthode de variation de résistance	453
Annexe F (normative)	Essai de résistance à la corrosion sous contrainte du cuivre et des alliages de cuivre	455
F.1	Enceinte d'essai	455
F.2	Solution d'essai	455
F.3	Élément d'essai	455
F.4	Procédure d'essai	456
Annexe G (normative)	Mesurages du courant de contact et du courant dans le conducteur de protection	457
G.1	Généralités	457
G.2	Conditions d'essai	457
G.3	Procédures d'essai	457
G.4	Mesurages d'essai	457
G.5	Séquence d'essais	459
Annexe H (informative)	Explication des numéros IP des degrés de protection	462
Annexe I (informative)	Mesurages de température	464
I.1	Mesurages de température des luminaires	464
I.2	Mesurage des températures des parties isolantes des douilles de lampe	465
Annexe J (informative)	Lignes directrices en matière de bonnes pratiques dans la conception des luminaires	467
J.1	Généralités	467
J.2	Utilisation des matières plastiques dans les luminaires	467
J.3	Résistance à la rouille	468
J.4	Résistance à la corrosion	468
J.5	Atmosphères chimiquement corrosives	469
J.6	Conception des réflecteurs	469
J.7	Composants utilisés dans différents types de luminaires	470

J.8	Recommandations pour la protection des ballasts électromagnétiques en ce qui concerne les phénomènes de fin de vie des lampes DHI	471
J.9	Résistance contre les effets des vibrations	471
J.10	Inflammabilité des composants	472
J.11	Aimants permanents	472
Annexe K (normative) Détermination des lignes de fuite et distances dans l'air.....		473
Annexe L (Informative) Explication sur le marquage des luminaires qui ne sont pas conçus pour être installés sur des surfaces de montage normalement inflammables et recouverts de matériaux isolants.....		474
L.1	Généralités	474
L.2	Protection contre l'inflammation	474
L.3	Protection contre la chaleur	475
L.3.1	Généralités	475
L.3.2	Espacement.....	475
L.3.3	Mesurages de température de la surface de montage, dans des conditions anormales ou de ballast défectueux	475
L.4	Dispositifs de protection thermique	477
L.5	Suppression des exigences du marquage F	478
Annexe M (normative) Spécifications d'absorption pour les écrans de protection destinés à être installés dans les luminaires conçus pour lampes aux halogénures métalliques émettant un degré élevé de rayonnement UV.....		479
M.1	Généralités	479
M.2	Procédure A.....	479
M.3	Procédure B.....	480
Annexe N (informative) Essai de conformité en fabrication.....		481
N.1	Généralités	481
N.2	Essai	481
Annexe O (normative) Liste des paragraphes amendés qui contiennent des exigences particulièrement strictes ou essentielles qui nécessitent de resoumettre à l'essai les produits		483
Annexe P (normative) Exigences pour l'identification d'une famille ou d'une gamme de luminaires pour les essais de type		484
P.1	Généralités	484
P.2	Gamme ou famille de luminaires	484
Annexe Q (informative) Exigences supplémentaires pour les luminaires lorsqu'un degré élevé de disponibilité (catégorie de surtension III) peut être exigé.....		485
Q.1	Généralités	485
Q.2	Exigences pour la catégorie de surtension III.....	485
Annexe R (normative) Exigences d'essai supplémentaires pour les bornes avec contact automatique de terre de protection intégré pour connexion directe au corps du luminaire ou à ses parties		488
R.1	Exigences additionnelles au 9.2.1	488
R.1.1	Exigences relatives à la résistance mécanique	488
R.1.2	Essai de la fixation de la borne.....	488
R.1.3	Essai de la plaque support.....	488
R.2	Exigences additionnelles au 9.2.3	488
Annexe S (normative) Essai alternatif d'échauffement pour luminaires réalisés avec des matériaux thermoplastiques.....		490
S.1	Généralités	490

S.2	Essai d'échauffement des luminaires réalisés en matériau thermoplastique en rapport avec des conditions de défaut des appareillages de commande ou des appareils électroniques sans appareil de contrôle sensible à la température pour des lampes fluorescentes ≤ 70 W	490
Annexe T (normative)	Exigences pour l'isolation entre les parties actives des circuits et les parties conductrices accessibles	492
Annexe U (informative)	Informations concernant l'équipement source d'alimentation des luminaires de classe III par le biais d'un câblage de communication informatique.....	494
U.1	Généralités	494
U.2	Isolement du réseau d'alimentation	494
U.3	Limites électriques d'un PSE.....	494
Annexe V (informative)	Références croisées avec l'édition précédente de l'IEC 60598-1	496
Annexe W (normative)	Luminaires alimentés par batterie/EDLC.....	499
W.1	Généralités	499
W.2	Exigences d'essai générales et vérification	499
W.3	Marquage	501
W.3.1	Généralités	501
W.3.2	Luminaires avec batterie remplaçable	501
W.3.3	Piles-boutons.....	501
W.3.4	Autres piles normalisées (par exemple, AAA ou AA)	502
W.3.5	Luminaires avec batterie rechargeable remplaçable non normalisée	503
W.3.6	Luminaires avec batterie/EDLC non remplaçable par l'utilisateur	503
W.3.7	Luminaires avec batterie/EDLC non remplaçable	504
W.3.8	Luminaires alimentés par des unités d'alimentation dédiées externes	504
W.3.9	Luminaires rechargeables autres qu'ordinaires	504
W.3.10	Conditions de charge	504
W.4	Construction	505
W.4.1	Généralités	505
W.4.2	Petites batteries (pièces, boutons et autres batteries non normalisées)	505
W.4.3	Éléments de fixation du compartiment de la batterie pour petites batteries et autres batteries normalisées (par exemple, AAA ou AA).....	506
W.4.4	Chargeurs de batteries/d'EDLC incorporés dans des luminaires	506
W.4.5	Protection contre les courts-circuits	506
W.4.6	Paramètres électriques du fonctionnement des batteries	507
W.4.7	Protection contre la suppression pour les batteries Li-ion utilisées dans les luminaires	508
W.4.8	Protection contre les conséquences d'une défaillance des éléments ou des EDLC	509
W.5	Protection contre les chocs électriques	509
W.6	Essai d'endurance et essai d'échauffement.....	510
W.6.1	Essai d'endurance	510
W.6.2	Essai d'échauffement (fonctionnement normal).....	510
W.6.3	Essai d'échauffement (fonctionnement anormal)	511
W.6.4	Systèmes de charge au lithium-ion – Conditions de défaut	512
Bibliographie.....		514
Figure 1 – Exemple de "repiquage" (passage en coupure)		281
Figure 2 – Exemples de "lignes traversantes"		282

Figure 3 – Exemple de système de contact électromécanique avec connexion fiche ou socle.....	284
Figure 4 – Alimentation en courant alternatif.....	303
Figure 5 – Alimentation en courant continu.....	303
Figure 6 – Alimentation en courant continu et alternatif.....	303
Figure 7 – Classe II.....	304
Figure 8 – Classe III.....	304
Figure 9 – Luminaires non conçus pour montage direct sur des surfaces normalement inflammables.....	306
Figure 10 – Lampes sodium à haute pression qui nécessitent un amorceur externe (à la lampe).....	306
Figure 11 – Lampes sodium à haute pression qui ont un appareil d'amorçage interne.....	306
Figure 12 – Avertissement contre l'usage des lampes à faisceau froid.....	307
Figure 13 – Mise à la terre fonctionnelle.....	307
Figure 14 – Mise à la terre de protection.....	307
Figure 15 – Distance minimale des objets éclairés (mètres).....	308
Figure 16 – Conditions sévères d'emploi.....	308
Figure 17 – Lampe à calotte argentée.....	309
Figure 18 – Remplacer tout écran de protection fissuré.....	309
Figure 19 – Circuit d'essai pour le contrôle de la sécurité lors de l'insertion des lampes.....	310
Figure 20 – Lampe autoprotégée.....	310
Figure 21 – Luminaires avec fusible interne.....	310
Figure 22 – Ne pas fixer la source de lumière en cours de fonctionnement.....	311
Figure 23 – Danger, risque de chocs électriques.....	312
Figure 24 – Emploi de câble d'alimentations, d'interconnexions ou de câblages externes résistants à la chaleur.....	313
Figure 25 – Pictogramme pour une source de lumière non remplaçable.....	315
Figure 26 – Pictogramme pour une source de lumière non remplaçable par l'utilisateur.....	315
Figure 27 – Pictogramme pour une source de lumière remplaçable.....	316
Figure 28 – Pictogramme pour un appareillage de commande non remplaçable.....	317
Figure 29 – Pictogramme pour un appareillage de commande non remplaçable par l'utilisateur final.....	318
Figure 30 – Pictogramme pour un appareillage de commande remplaçable.....	318
Figure 31 – Bloc de jonction pour essai de pose de luminaire à câbles de raccordement (sorties).....	322
Figure 32 – Exemples de vis à tôle et de vis autotaraudeuses par enlèvement ou déformation de matière.....	328
Figure 33 – Représentation des exigences du 7.15.1.....	340
Figure 34 – Appareil pour les essais de choc à la bille.....	345
Figure 35 – Chaîne d'essai.....	351
Figure 36 – Exemple de degré d'étamage admis.....	366
Figure 37 – Circuit pour vérifier le contact électrique entre un socle de prise de courant et une fiche.....	367
Figure 38 – Essai pour déterminer l'adéquation des conducteurs ayant une section transversale réduite.....	372

Figure 39 – Exemple de vis autotaraudeuse utilisée dans la rainure d'un matériau métallique	373
Figure 40 – Appareil pour la vérification de la protection contre les poussières	383
Figure 41 – Appareil pour la vérification de la protection contre la pluie et les projections d'eau.....	384
Figure 42 – Buse pour essai de pluie fine	386
Figure 43 – Représentation des mesurages des lignes de fuite et distances dans l'air au niveau d'une borne d'alimentation	396
Figure 44 – Circuit d'essai pour les luminaires incorporant des lampes fluorescentes ≤ 70 W	416
Figure 45 – Appareil pour l'essai de pression à la bille.....	419
Figure 46 – Bornes à trou	422
Figure 47 – Bornes à serrage sous tête de vis et bornes à goujon fileté.....	424
Figure 48 – Bornes à plaquette	425
Figure 49 – Bornes pour cosses et barrettes.....	426
Figure 50 – Bornes à capot taraudé	427
Figure 51 – Construction de connexions électriques	434
Figure 52 – Exemples de bornes sans vis, du type à serrage par ressort	434
Figure 53 – Autres exemples de connexions sans vis	435
Figure C.1 – Circuit d'essai pour l'effet redresseur (certains ballasts capacitifs sans starter seulement).....	449
Figure C.2 – Circuit d'essai pour l'effet redresseur (ballasts pour lampes à une broche)	450
Figure C.3 – Circuit d'essai pour l'effet redresseur de certaines lampes aux halogénures métalliques et certaines lampes sodium haute pression	450
Figure G.1 – Configuration d'essai: équipement monophasé en schéma TN ou TT en étoile	460
Figure G.2 – Réseau de mesure, courant de contact pondéré pour perception ou réaction	460
Figure G.3 – Réseau de mesure, courant de contact pondéré pour "let-go" (pour les luminaires portatifs de classe I)	460
Figure G.4 – Réseau de mesure, calibré pour une haute fréquence	461
Figure I.1 – Emplacement des thermocouples sur une douille type	466
Figure L.1 – Relation entre la température d'enroulement et la température de la surface de montage	476
Figure L.2 – Température d'inflammation du bois en fonction du temps	477
Figure R.1 – Disposition pour l'essai de chute de tension	489
Figure T.1 – Déclaration de LV_{supply} et U_{out} et les barrières d'isolation entre la source de lumière et les parties accessibles	492
Tableau 1 – Marquage	302
Tableau 2 – Indices IP du degré de protection contre la pénétration des poussières, des corps solides et de l'humidité	305
Tableau 3 – Identification des câbles de raccordement et des bornes de très basse tension en courant continu	308
Tableau 4 – Vue d'ensemble des condensateurs Y exigés.....	327
Tableau 5 – Essais de couple sur les vis	331
Tableau 6 – Essais de torsion sur les presse-étoupes.....	333

Tableau 7 – Énergies de choc et compression du ressort.....	334
Tableau 8 – Essai des semi-luminaires	338
Tableau 9 – Essai des appareils de réglage.....	339
Tableau 10 – Courant de décharge nominal (utilisé dans l'essai sur ondes combinées)	357
Tableau 11 – Cordons d'alimentation	361
Tableau 12 – Caractéristiques du câblage	362
Tableau 13 – Essais du dispositif d'arrêt de traction	365
Tableau 14 – Essai des luminaires étanches aux objets solides.....	382
Tableau 15 – Résistance d'isolement minimale	390
Tableau 16 – Rigidité diélectrique	392
Tableau 17 – Limites des courants de contact ou des courants dans le conducteur de protection et brûlure électrique	394
Tableau 18 – Lignes de fuite minimales pour tensions sinusoïdales en courant alternatif jusqu'à 30 kHz (à utiliser conjointement avec l'Annexe K)	397
Tableau 19 – Distances dans l'air minimales pour tensions de service (à utiliser conjointement avec l'Annexe K)	398
Tableau 20 – Distances minimales pour tensions d'impulsion d'amorçage ou tension de crête transformée équivalente U_p	399
Tableau 21 – Températures maximales dans les conditions d'essai du 14.4.3 pour les parties principales.....	406
Tableau 22 – Températures maximales dans les conditions d'essai du 14.4.3 pour les matériaux communs utilisés dans les luminaires	407
Tableau 23 – Températures maximales dans les conditions de l'essai du 14.5.2.....	411
Tableau 24 – Températures maximales des enroulements dans des conditions de fonctionnement anormales et à 110 % de la tension assignée pour l'appareillage de commande	412
Tableau 25 – Températures maximales des enroulements dans les conditions de fonctionnement anormales et à 110 % de la tension assignée pour les appareillages de commande marqués "D6".....	412
Tableau 26 – Limite du temps de dépassement de la température	415
Tableau 27 – Sections nominales des conducteurs selon la taille de la borne	429
Tableau 28 – Sections nominales des conducteurs selon le courant maximal	429
Tableau 29 – Composition des conducteurs.....	430
Tableau 30 – Couple à appliquer aux vis et aux écrous.....	432
Tableau 31 – Force de traction appliquée au conducteur	433
Tableau 32 – Caractéristiques assignées des conducteurs	440
Tableau 33 – Force de traction sur les conducteurs	441
Tableau F.1 – pH de la solution d'essai	455
Tableau G.1 – Position des interrupteurs e, n et p pour les mesurages des différentes classes de luminaires	459
Tableau H.1 – Degrés de protection indiqués par le premier chiffre caractéristique.....	462
Tableau H.2 – Degrés de protection indiqués par le deuxième chiffre caractéristique.....	463
Tableau J.1 – Influences nuisibles	467
Tableau K.1 – Détermination des lignes de fuite et distances dans l'air (voir Tableau 18, Tableau 19 et Tableau 20).....	473

Tableau L.1 – Recommandations relatives aux cas d'utilisation du symbole et son explication figurant sur le luminaire ou dans la notice du fabricant fournie avec le luminaire.....	474
Tableau L.2 – Fonctionnement avec protection thermique.....	478
Tableau N.1 – Valeurs minimales pour les essais électriques	482
Tableau Q.1 – Distances dans l'air minimales pour les tensions de service sinusoïdales en courant alternatif – Catégorie de surtension III	486
Tableau Q.2 – Vue d'ensemble des condensateurs Y exigés	486
Tableau Q.3 – Courant de décharge nominal (utilisé dans l'essai sur ondes combinées).....	487
Tableau T.1 – Exigences d'isolation entre les parties actives et les parties conductrices accessibles.....	493
Tableau U.1 – Limites des paramètres électriques d'un PSE.....	494
Tableau U.2 – Paramètres électriques pour les connecteurs ou câbles de communication.....	495
Tableau V.1 – Références croisées.....	496
Tableau W.1 – Caractéristiques des sources artificielles.....	500
Tableau W.2 – Surface totale des ouvertures pour les éléments Li-ion.....	509
Tableau W.3 – Volume d'air injecté à 2 070 kPa	509

IECNORM.COM : Click to view the full PDF of IEC 60598-1:2024

COMMISSION ÉLECTROTECHNIQUE INTERNATIONALE

LUMINAIRES –

Partie 1: Exigences générales et essais

AVANT-PROPOS

- 1) La Commission Électrotechnique Internationale (IEC) est une organisation mondiale de normalisation composée de l'ensemble des comités électrotechniques nationaux (Comités nationaux de l'IEC). L'IEC a pour objet de favoriser la coopération internationale pour toutes les questions de normalisation dans les domaines de l'électricité et de l'électronique. À cet effet, l'IEC – entre autres activités – publie des Normes internationales, des Spécifications techniques, des Rapports techniques, des Spécifications accessibles au public (PAS) et des Guides (ci-après dénommés "Publication(s) de l'IEC"). Leur élaboration est confiée à des comités d'études, aux travaux desquels tout Comité national intéressé par le sujet traité peut participer. Les organisations internationales, gouvernementales et non gouvernementales, en liaison avec l'IEC, participent également aux travaux. L'IEC collabore étroitement avec l'Organisation Internationale de Normalisation (ISO), selon des conditions fixées par accord entre les deux organisations.
- 2) Les décisions ou accords officiels de l'IEC concernant les questions techniques représentent, dans la mesure du possible, un accord international sur les sujets étudiés, étant donné que les Comités nationaux de l'IEC intéressés sont représentés dans chaque comité d'études.
- 3) Les Publications de l'IEC se présentent sous la forme de recommandations internationales et sont agréées comme telles par les Comités nationaux de l'IEC. Tous les efforts raisonnables sont entrepris afin que l'IEC s'assure de l'exactitude du contenu technique de ses publications; l'IEC ne peut pas être tenue responsable de l'éventuelle mauvaise utilisation ou interprétation qui en est faite par un quelconque utilisateur final.
- 4) Dans le but d'encourager l'uniformité internationale, les Comités nationaux de l'IEC s'engagent, dans toute la mesure possible, à appliquer de façon transparente les Publications de l'IEC dans leurs publications nationales et régionales. Toutes divergences entre toutes Publications de l'IEC et toutes publications nationales ou régionales correspondantes doivent être indiquées en termes clairs dans ces dernières.
- 5) L'IEC elle-même ne fournit aucune attestation de conformité. Des organismes de certification indépendants fournissent des services d'évaluation de conformité et, dans certains secteurs, accèdent aux marques de conformité de l'IEC. L'IEC n'est responsable d'aucun des services effectués par les organismes de certification indépendants.
- 6) Tous les utilisateurs doivent s'assurer qu'ils sont en possession de la dernière édition de cette publication.
- 7) Aucune responsabilité ne doit être imputée à l'IEC, à ses administrateurs, employés, auxiliaires ou mandataires, y compris ses experts particuliers et les membres de ses comités d'études et des Comités nationaux de l'IEC, pour tout préjudice causé en cas de dommages corporels et matériels, ou de tout autre dommage de quelque nature que ce soit, directe ou indirecte, ou pour supporter les coûts (y compris les frais de justice) et les dépenses découlant de la publication ou de l'utilisation de cette Publication de l'IEC ou de toute autre Publication de l'IEC, ou au crédit qui lui est accordé.
- 8) L'attention est attirée sur les références normatives citées dans cette publication. L'utilisation de publications référencées est obligatoire pour une application correcte de la présente publication.
- 9) L'IEC attire l'attention sur le fait que la mise en application du présent document peut entraîner l'utilisation d'un ou de plusieurs brevets. L'IEC ne prend pas position quant à la preuve, à la validité et à l'applicabilité de tout droit de brevet revendiqué à cet égard. À la date de publication du présent document, l'IEC n'avait pas reçu notification qu'un ou plusieurs brevets pouvaient être nécessaires à sa mise en application. Toutefois, il y a lieu d'avertir les responsables de la mise en application du présent document que des informations plus récentes sont susceptibles de figurer dans la base de données de brevets, disponible à l'adresse <https://patents.iec.ch>. L'IEC ne saurait être tenue pour responsable de ne pas avoir identifié de tels droits de brevets.

L'IEC 60598-1 a été établie par le sous-comité 34D: Luminaires, du comité d'études 34 de l'IEC: Éclairage. Il s'agit d'une Norme internationale.

Cette dixième édition annule et remplace la neuvième édition parue en 2020. Cette édition constitue une révision technique.

Cette édition inclut les modifications techniques majeures suivantes par rapport à l'édition précédente:

- a) nouvelle structure conforme aux Directives ISO/IEC, Partie 2;
- b) ajout d'une nouvelle Annexe V pour comparaison à l'édition précédente;

- c) révision du 7.32 pour SPD et pour SPC;
- d) examen et alignement des termes "partie sous-tension" et "partie active" sur les définitions des termes "parties actives" et "parties actives dangereuses" données dans l'IEC 60050-195;
- e) révision du 7.14.2 pour la contrainte mécanique des conducteurs;
- f) révision du 14.5.2, Point 4 pour inclure l'appareillage de commande;
- g) révision du 9.2.1 (Mise à la terre) avec suppression de l'expression "de manière permanente";
- h) révision de l'Annexe N: temps d'essai de continuité de la terre;
- i) révision du 7.11.4, du 7.14.1 et du Tableau 22 (14.4.3): introduction d'exigences relatives à la suspension par des aimants;
- j) ajout d'une nouvelle Annexe W pour les luminaires qui utilisent des batteries;
- k) clarification de l'6 pour les exigences de marquage du type d'alimentation;
- l) ajout d'un nouveau 7.31.5: exigences supplémentaires pour les luminaires qui utilisent des appareillages commandables qui fournissent une ou plusieurs sorties TBTS;
- m) révision du 6.4.16: informations à fournir pour un luminaire qui a un courant de terre de protection > 10 mA;
- n) révision du 6.3.23, du 6.4.18, du 6.4.24, du 7.30 et du 10.2.1 pour les composants remplaçables, non remplaçable par l'utilisateur final et non remplaçables;
- o) révision du Annexe D: enceinte à air calme;
- p) révision du 8.2.1 et du 13.2.1: incohérences dans l'inclusion des limites des plages de tensions;
- q) révision du 9.2.10 pour le repiquage;
- r) révision de l'Article 2 et du 7.8: mise à jour de la référence à l'IEC 61058-1-1, à l'IEC 61058-1-2 et à l'IEC 61058-2-1. Mise à jour des limites de température du Tableau 21 (14.4.3) pour les luminaires qui comportent des interrupteurs conformément à l'IEC 60669-1 ou à l'IEC 60669-2-1;
- s) révision du 6.3.22 et du 7.24 pour la sécurité photobiologique;
- t) ajout d'un nouveau 6.3.27 pour le marquage des socles de prise de courant réseau, déplacé des exigences relatives aux informations.

Les modifications majeures qui peuvent avoir un impact sur la certification des produits sont indiquées à l'Annexe O.

L'Annexe O indique où un nouveau texte a été introduit comportant des exigences majeures ou critiques imposant que le produit soit de nouveau soumis à l'essai.

Le texte de cette Norme internationale est issu des documents suivants:

Projet	Rapport de vote
34D/1739/FDIS	34D/1751/RVD

Le rapport de vote indiqué dans le tableau ci-dessus donne toute information sur le vote ayant abouti à son approbation.

La langue employée pour l'élaboration de cette Norme internationale est l'anglais.

Ce document a été rédigé selon les Directives ISO/IEC, Partie 2, il a été développé selon les Directives ISO/IEC, Partie 1 et les Directives ISO/IEC, Supplément IEC, disponibles sous www.iec.ch/members_experts/refdocs. Les principaux types de documents développés par l'IEC sont décrits plus en détail sous www.iec.ch/publications.

Lorsqu'elle utilise le présent document avec les parties déjà publiées de la série IEC 60598-2, l'Annexe V du présent document doit être utilisé pour mettre à jour le référencement croisé de la partie correspondante de la série IEC 60598-2 à la nouvelle structure du présent document. Les projets du 34D qui visent à mettre à jour la structure de la série IEC 60598-2 conformément à la nouvelle structure du présent document vont suivre.

Une liste de toutes les parties de la série IEC 60598, publiées sous le titre général *Luminaires*, se trouve sur le site web de l'IEC.

NOTE Dans le présent document, les caractères d'imprimerie suivants sont utilisés:

- exigences: caractères romains;
- *modalités d'essais: caractères italiques;*
- notes: petits caractères romains.

Le comité a décidé que le contenu de ce document ne sera pas modifié avant la date de stabilité indiquée sur le site web de l'IEC sous webstore.iec.ch dans les données relatives au document recherché. À cette date, le document sera

- reconduit,
- supprimé, ou
- révisé.

IMPORTANT – Le logo "colour inside" qui se trouve sur la page de couverture de ce document indique qu'il contient des couleurs qui sont considérées comme utiles à une bonne compréhension de son contenu. Les utilisateurs devraient, par conséquent, imprimer ce document en utilisant une imprimante couleur.

INTRODUCTION

De manière générale, le présent document 1 traite des exigences relatives à la sécurité applicables aux luminaires. L'objet du présent document est de fournir un ensemble d'exigences et d'essais généralement considérés comme applicables à la plupart des types de luminaires et qui peuvent être exigés dans les spécifications particulières de la série IEC 60598-2. Le présent document n'est donc pas considéré comme une spécification en soi pour un type quelconque de luminaire, mais ses dispositions ne s'appliquent qu'à des types particuliers de luminaires, dans la limite définie par une partie appropriée de la série IEC 60598-2.

Chaque partie de la série IEC 60598-2 décrit les exigences applicables à un type particulier de luminaire ou groupe de luminaires. Ces parties de la série IEC 60598-2 sont publiées séparément pour faciliter leur révision et permettre l'addition de nouveaux documents, au fur et à mesure de la nécessité de la parution de ces derniers.

La série IEC 60598-2 comprend les parties suivantes:

- IEC 60598-2-1: Luminaires fixes à usage général
- IEC 60598-2-2: Luminaires encastrés et luminaires à circulation d'air encastrés
- IEC 60598-2-3: Luminaires d'éclairage public
- IEC 60598-2-4: Luminaires portatifs à usage général
- IEC 60598-2-5: Projecteurs
- IEC 60598-2-6: Luminaires à transformateur intégré pour lampes à filament de tungstène (supprimée)
- IEC 60598-2-7: Luminaires portatifs pour emploi dans les jardins (supprimée)
- IEC 60598-2-8: Baladeuses
- IEC 60598-2-9: Luminaires pour prises de vues photographiques et cinématographiques (non professionnels) (supprimée)
- IEC 60598-2-10: Luminaires portatifs pour enfants
- IEC 60598-2-11: Luminaires pour aquarium
- IEC 60598-2-12: Veilleuses montées sur des socles de prise de courant réseau
- IEC 60598-2-13: Luminaires encastrés dans le sol
- IEC 60598-2-14: Luminaires pour lampes à décharge tubulaire à cathode froide (tubes néons) et équipements similaires
- IEC 60598-2-15: Non utilisée actuellement
- IEC 60598-2-16: Non utilisée actuellement
- IEC 60598-2-17: Luminaires pour l'éclairage des scènes de théâtre, pour prises de vue de télévision et de cinéma (à l'extérieur et à l'intérieur)
- IEC 60598-2-18: Luminaires pour piscines et usages analogues
- IEC 60598-2-19: Luminaires à circulation d'air (règles de sécurité) (supprimée)
- IEC 60598-2-20: Guirlandes lumineuses
- IEC 60598-2-21: Cordons lumineux
- IEC 60598-2-22: Luminaires pour éclairage de secours
- IEC 60598-2-23: Systèmes d'éclairage à très basse tension pour lampes à filament
- IEC 60598-2-24: Luminaires avec surfaces à températures limitées
- IEC 60598-2-25: Luminaires pour les unités de soins des hôpitaux et les maisons de santé

LUMINAIRES –

Partie 1: Exigences générales et essais

1 Domaine d'application

La présente partie de l'IEC 60598 spécifie les exigences de sécurité générales pour les luminaires qui incorporent des sources de lumière électriques destinées à fonctionner avec des tensions d'alimentation jusqu'à 1 000 V.

Les exigences relatives aux semi-luminaires sont incluses dans le présent document.

Dans le cas des luminaires pour atmosphère explosive, spécifiés dans la série IEC 60079, les exigences de la série IEC 60598 (en sélectionnant les parties appropriées de la série IEC 60598-2) s'appliquent avec les exigences de la série IEC 60079. En cas d'incompatibilité entre la série IEC 60598 et la série IEC 60079, les exigences de la série IEC 60079 prévalent.

Le présent document ne couvre pas les performances. Les performances des luminaires sont couvertes par la série IEC 62722.

2 Références normatives

Les documents suivants sont cités dans le texte de sorte qu'ils constituent, pour tout ou partie de leur contenu, des exigences du présent document. Pour les références datées, seule l'édition citée s'applique. Pour les références non datées, la dernière édition du document de référence s'applique (y compris les éventuels amendements).

IEC 60061-2, *Culots de lampes et douilles ainsi que calibres pour le contrôle de l'interchangeabilité et de la sécurité – Partie 2: Douilles*, disponible à <http://std.iec.ch/iec60061>

IEC 60061-3, *Culots de lampes et douilles ainsi que calibres pour le contrôle de l'interchangeabilité et de la sécurité – Partie 3: Calibres*, disponible à l'adresse <http://std.iec.ch/iec60061>

IEC 60068-2-6, *Essais d'environnement – Partie 2-6: Essais – Essai Fc: Vibrations (sinusoïdales)*

IEC 60068-2-14:2023, *Essais d'environnement – Partie 2-14: Essais – Essais N: Variation de température*

IEC 60068-2-31:2008, *Essais d'environnement – Partie 2-31: Essais – Essai Ec: Choc lié à des manutentions brutales, essai destiné en premier lieu aux matériels*

IEC 60068-2-75, *Essais d'environnement – Partie 2-75: Essais – Essai Eh: Essais au marteau*

IEC TR 60083, *Prises de courant pour usages domestiques et analogues normalisées par les pays membres de l'IEC*

IEC 60085, *Isolation électrique – Évaluation et désignation thermiques*

IEC 60112:2020, *Méthode de détermination des indices de résistance et de tenue au cheminement des matériaux isolants solides*

IEC 60155, *Interrupteurs d'amorçage à lueur pour lampes à fluorescence (starters)*

IEC 60227 (toutes les parties), *Conducteurs et câbles isolés au polychlorure de vinyle, de tension nominale au plus égale à 450/750 V*

IEC 60238:2016, *Douilles à vis Edison pour lampes*

IEC 60245 (toutes les parties), *Conducteurs et câbles isolés au caoutchouc – Tension assignée au plus égale à 450/750 V*

IEC 60320 (toutes les parties), *Connecteurs pour usages domestiques et usages généraux analogues*

IEC 60335-1:2020, *Appareils électrodomestiques et analogues – Sécurité – Partie 1: Exigences générales*

IEC 60360, *Méthode normalisée de mesure de l'échauffement d'un culot de lampe*

IEC 60384-14, *Condensateurs fixes utilisés dans les équipements électroniques – Partie 14: Spécification intermédiaire – Condensateurs fixes pour la suppression des interférences électromagnétiques et la connexion au réseau d'alimentation*

IEC 60417, *Symboles graphiques utilisables sur le matériel*, disponible à l'adresse <http://www.graphical-symbols.info/equipment>

IEC 60432-1:1999, *Lampes à incandescence – Prescriptions de sécurité – Partie 1: Lampes à filament de tungstène pour usage domestique et éclairage général similaire*

IEC 60432-1:1999/AMD1:2005

IEC 60432-1:1999/AMD2:2011

IEC 60432-2:1999, *Lampes à incandescence – Prescriptions de sécurité – Partie 2: Lampes tungstène-halogène pour usage domestique et éclairage général similaire*

IEC 60432-2:1999/AMD1:2005

IEC 60432-2:1999/AMD2:2012

IEC 60529, *Degrés de protection procurés par les enveloppes (Code IP)*

IEC 60570:2003, *Systèmes d'alimentation électrique par rail pour luminaires*

IEC 60570:2003/AMD1:2017

IEC 60570:2003/AMD2:2019

IEC 60598-2 (toutes les parties), *Luminaires – Partie 2: Exigences particulières*

IEC 60598-2-4:2017, *Luminaires – Partie 2-4: Exigences particulières – Luminaires portatifs à usage général*

IEC 60603 (toutes les parties), *Connecteurs pour fréquences inférieures à 3 MHz pour utilisation avec cartes imprimées*

IEC 60662, *Lampes à vapeur de sodium à haute pression – Spécifications de performance*

IEC 60664-4:2005, *Coordination de l'isolement des matériels dans les systèmes (réseaux) à basse tension – Partie 4: Considérations sur les contraintes de tension à haute fréquence*

IEC 60669-1, *Interrupteurs pour installations électriques fixes domestiques et analogues – Partie 1: Exigences générales*

IEC 60669-2-1, *Interrupteurs pour installations électriques fixes domestiques et analogues – Partie 2-1: Exigences particulières – Dispositifs de commande électronique*

IEC 60684 (toutes les parties), *Gaines isolantes souples*

IEC 60695-2-11, *Essais relatifs aux risques du feu – Partie 2-11: Essais au fil incandescent/chauffant – Méthode d'essai d'inflammabilité pour produits finis (GWEPT)*

IEC 60695-11-5, *Essais relatifs aux risques du feu – Partie 11-5: Flammes d'essai – Méthode d'essai au brûleur-aiguille – Appareillage, dispositif d'essai de vérification et lignes directrices*

IEC 60990, *Méthodes de mesure du courant de contact et du courant dans le conducteur de protection*

IEC 60998-2-1, *Dispositifs de connexion pour circuits basse tension pour usage domestique et analogue – Partie 2-1: Règles particulières pour dispositifs de connexion en tant que parties séparées avec organes de serrage à vis*

IEC 60998-2-2, *Dispositifs de connexion pour circuits basse tension pour usage domestique et analogue – Partie 2-2: Règles particulières pour dispositifs de connexion en tant que parties séparées avec organes de serrage sans vis*

IEC 61032:1997, *Protection des personnes et des matériels par les enveloppes – Calibres d'essai pour la vérification*

IEC 61051-2:2021, *Varistances utilisées dans les équipements électroniques – Partie 2: Spécification intermédiaire pour varistances pour limitations de surtensions transitoires*

IEC 61058-1:2016, *Interrupteurs pour appareils – Partie 1: Exigences générales*

IEC 61058-1-1, *Interrupteurs pour appareils – Partie 1-1: Exigences relatives aux interrupteurs mécaniques*

IEC 61058-1-2, *Interrupteurs pour appareils – Partie 1-2: Exigences relatives aux interrupteurs électriques*

IEC 61058-2-1, *Interrupteurs pour appareils – Partie 2-1: Exigences particulières pour les interrupteurs pour câbles souples*

IEC 61167, *Lampes aux halogénures métalliques – Spécifications de performances*

IEC 61249 (toutes les parties), *Matériaux pour circuits imprimés et autres structures d'interconnexion*

IEC 61347 (toutes les parties), *Appareillages de lampes*

IEC 61347-1:2015, *Appareillages de lampes – Partie 1: Exigences générales et exigences de sécurité*

IEC 61347-1:2015/AMD1:2017

IEC 61535:2023, *Coupleurs d'installation pour connexions permanentes dans les installations fixes*

IEC 61558 (toutes les parties), *Sécurité des transformateurs, bobines d'inductance, blocs d'alimentation et des combinaisons de ces éléments*

IEC 61558-1:2017, *Sécurité des transformateurs, bobines d'inductance, blocs d'alimentation et des combinaisons de ces éléments – Partie 1: Exigences générales et essais*

IEC 61643-11, *Parafoudres basse tension – Partie 11: Parafoudres connectés aux systèmes basse tension – Exigences et méthodes d'essai*

IEC 61643-331:2020, *Composants pour parafoudres basse tension – Partie 331: Exigences de performances et méthodes d'essai pour les varistances à oxyde métallique (MOV)*

IEC 61984:2008, *Connecteurs – Exigences de sécurité et essais*

IEC 62133-2, *Accumulateurs alcalins et autres accumulateurs à électrolyte non acide – Exigences de sécurité pour les accumulateurs portables étanches, et pour les batteries qui en sont constituées, destinés à l'utilisation dans des applications portables – Partie 2: Systèmes au lithium*

IEC 62368-1: 2018, *Équipements des technologies de l'audio/vidéo, de l'information et de la communication – Partie 1: Exigences de sécurité*

IEC 62391-1, *Condensateurs électriques fixes à double couche utilisés dans les équipements électriques et électroniques – Partie 1: Spécification générique*

IEC 62391-2, *Condensateurs électriques fixes à double couche utilisés dans les équipements électroniques – Partie 2: Spécification intermédiaire – Condensateurs électriques à double couche pour application de puissance*

IEC 62471-7:2023, *Sécurité photobiologique des lampes et des appareils utilisant des lampes – Partie 7: Sources de lumière et luminaires qui émettent principalement un rayonnement visible*

IEC 62493:2015, *Évaluation d'un équipement d'éclairage relativement à l'exposition humaine aux champs électromagnétiques*
IEC 62493:2015/AMD1:2022

IEC 62680 (toutes les parties), *Interfaces de bus universel en série pour les données et l'alimentation électrique*

IEC TR 62778:2014¹, *Application of IEC 62471 for the assessment of blue light hazard to light sources and luminaires* (disponible en anglais seulement)

ISO 3864-1, *Symboles graphiques – Couleurs de sécurité et signaux de sécurité – Partie 1: Principes de conception pour les signaux de sécurité et les marquages de sécurité*

ISO 7000, *Symboles graphiques utilisables sur le matériel – Symboles enregistrés*, disponible à l'adresse <https://www.graphical-symbols.info/equipment>

ISO 8124-1:2022, *Sécurité des jouets – Partie 1: Aspects de sécurité relatifs aux propriétés mécaniques et physiques*

¹ Supprimée.

3 Termes et définitions

Pour les besoins du présent document, les termes et définitions suivants s'appliquent.

L'ISO et l'IEC tiennent à jour des bases de données terminologiques destinées à être utilisées en normalisation, consultables aux adresses suivantes:

- IEC Electropedia: disponible à l'adresse <http://www.electropedia.org/>
- ISO Online browsing platform: disponible à l'adresse <https://www.iso.org/obp>

NOTE D'autres définitions relatives aux sources de lumière peuvent être consultées dans les normes de sources de lumière correspondantes.

3.1

luminaire

appareil servant à répartir, filtrer ou transformer la lumière provenant d'au moins une source de rayonnement optique et qui comprend, à l'exclusion des sources elles-mêmes, toutes les pièces nécessaires pour fixer et protéger les sources et, si nécessaire, les circuits auxiliaires ainsi que les moyens permettant leur connexion à l'alimentation électrique

[SOURCE: IEC 60050-845:2020, 845-30-001]

3.2

partie principale

<d'un luminaire> partie fixée sur la surface d'appui ou suspendue directement à cette surface ou posée sur elle

Note 1 à l'article: La partie principale peut comprendre ou non les lampes, les douilles et l'appareillage auxiliaire.

Note 2 à l'article: Dans les luminaires pour lampes à filament de tungstène, la partie comprenant la douille est généralement la partie principale.

3.3

luminaire ordinaire

luminaire assurant une protection contre tout contact accidentel avec des parties actives dangereuses, mais ne comportant aucune autre protection spéciale contre la poussière, les corps solides ou l'humidité

[SOURCE: IEC 60050-845:2020, 845-30-006, modifié – "parties sous tension" a été remplacé par "parties actives dangereuses".]

3.4

luminaire pour usage général

luminaire qui n'est pas destiné à un usage spécial

Note 1 à l'article: Les exemples de luminaires à usage général incluent les suspensions, les spots et certains luminaires fixes pour montage sur une surface ou à encastrer. Les exemples de luminaires pour usage spécial sont ceux pour utilisations sévères, ceux pour applications photographiques et cinématographiques et pour les piscines.

3.5

luminaire ajustable

luminaire dont la partie principale peut être orientée ou déplacée à l'aide de raccords, d'appareils à contrepoids, de tubes télescopiques ou d'appareils similaires

Note 1 à l'article: Un luminaire ajustable peut être fixe ou mobile.

[SOURCE: IEC 60050-845:2020, 845-30-010]

3.6

luminaire de base

plus petit nombre de parties assemblées qui, associées, peuvent satisfaire aux exigences d'une des parties de la série IEC 60598-2

3.7

luminaire combiné

luminaire composé d'un luminaire de base, combiné avec une ou plusieurs pièces pouvant être remplacées, ou utilisées en une combinaison différente avec d'autres pièces et changées soit à la main soit à l'aide d'outils

3.8

luminaire fixe

luminaire qui ne peut pas être déplacé facilement d'un endroit à un autre, soit parce que la fixation est réalisée de sorte que le luminaire ne puisse être retiré qu'à l'aide d'un outil, soit parce qu'il est destiné à être utilisé à l'extérieur d'un volume d'accessibilité au toucher

Note 1 à l'article: En général, les luminaires fixes sont conçus pour un raccordement permanent au réseau d'alimentation, mais le raccordement peut aussi être effectué au moyen d'une fiche de prise de courant ou d'un appareil similaire.

[SOURCE: IEC 60050-845:2020, 845-30-013]

3.9

luminaire mobile

luminaire portatif

luminaire qui peut être aisément déplacé d'un endroit à un autre tout en restant connecté à l'alimentation électrique

Note 1 à l'article: Les luminaires à montage mural équipés d'un cordon d'alimentation pour raccordement à une fiche de prise de courant et les luminaires qui peuvent être fixés sur leur support au moyen d'une vis à oreilles, une attache ou un crochet de manière à pouvoir être retirés à la main facilement de leur support, sont considérés comme des luminaires mobiles ou portatifs.

[SOURCE: IEC 60050-845:2020, 845-30-011]

3.10

luminaire encastré

luminaire conçu par le fabricant pour être entièrement ou partiellement encastré dans une surface d'appui

Note 1 à l'article: Le terme s'applique tant aux luminaires destinés à être utilisés dans des cavités fermées qu'aux luminaires destinés à être installés au travers d'une surface telle qu'un plafond suspendu.

[SOURCE: IEC 60050-845:2020, 845-30-018]

3.11

tension assignée

tension d'alimentation ou tensions d'alimentation pour laquelle ou lesquelles le luminaire a été conçu par le fabricant

3.11.1

tension constante d'entrée assignée

tension d'entrée ou tensions d'entrée assignées par le fabricant aux luminaires non équipés d'appareillage

Note 1 à l'article: La tension constante d'entrée assignée du luminaire correspond à la tension de sortie assignée pour les appareillages à tension constante.

3.12

courant d'alimentation

courant aux bornes de l'alimentation lorsque le luminaire s'est stabilisé à son régime normal à sa tension et à sa fréquence assignées

Note 1 à l'article: Le courant d'alimentation est exprimé généralement en ampère (A).

[SOURCE: IEC 60050-845:2020, 845-27-120, modifié – "lorsque le luminaire s'est stabilisé à son régime normal à sa tension et à sa fréquence assignées" a été ajouté.]

3.12.1

courant constant d'entrée assigné

courant d'entrée ou courants d'entrée assignés par le fabricant aux luminaires non équipés d'appareillage

Note 1 à l'article: Le courant constant d'entrée assigné du luminaire correspond au courant de sortie assigné pour les appareillages à courant constant.

3.13

puissance assignée

nombre et puissance assignée des lampes pour lesquelles le luminaire est conçu, ou puissance d'entrée du luminaire dans le cas d'autres sources de lumière

Note 1 à l'article: Les modules LED peuvent être d'autres sources de lumière.

3.14

cordon d'alimentation

câble ou cordon extérieur souple fixé au luminaire et destiné à son alimentation

Note 1 à l'article: Les luminaires peuvent être équipés du cordon d'alimentation ou conçus pour être utilisés avec des fixations du cordon d'alimentation de type X, Y ou Z par exemple.

Note 2 à l'article: Un cordon d'alimentation peut être appelé câble ou cordon souple fixé à demeure.

3.15

partie active

partie sous tension

<électrique> partie conductrice destinée à être sous tension dans des conditions normales de fonctionnement, y compris le conducteur neutre et le conducteur de point milieu, à l'exception toutefois du conducteur PEN, du conducteur PEM et du conducteur PEL

Note 1 à l'article: Cette notion n'implique pas nécessairement un risque de choc électrique.

Note 2 à l'article: Cette définition est essentiellement équivalente au terme "partie active" utilisé dans la neuvième édition de la présente norme.

Note 3 à l'article: Pour les définitions de PEN, PEM et PEL, voir l'IEC 60050-195.

[SOURCE: IEC 60050-195:2021, 195-02-19, modifié – Les Notes à l'article ont été ajoutées.]

3.16

partie active dangereuse **partie sous tension dangereuse**

partie active qui peut provoquer, dans certaines conditions, un choc électrique nuisible

Note 1 à l'article: L'essai destiné à déterminer si une partie conductrice est une partie active qui peut causer un choc électrique est décrit à l'Annexe A.

Note 2 à l'article: Le conducteur neutre est, cependant, considéré comme une partie active dangereuse.

Note 3 à l'article: Cette définition est essentiellement équivalente à la définition de "partie active" donnée dans la neuvième édition du présent document.

[SOURCE: IEC 60050-195:2021, 195-06-05, modifié – La Note 1 à l'article a été remplacée par trois nouvelles Notes à l'article.]

3.17

isolation principale

isolation qui assure la protection principale

Note 1 à l'article: Cette notion n'est pas applicable à l'isolation exclusivement utilisée à des fins fonctionnelles.

[SOURCE: IEC 60050-195:2021, 195-06-06]

3.18

protection principale

protection contre les chocs électriques dans des conditions normales

[SOURCE: IEC 60050-195:2021, 195-06-01]

3.19

isolation supplémentaire

isolation indépendante prévue, en plus de l'isolation principale, en tant que protection en cas de défaut

[SOURCE: IEC 60050-195:2021, 195-06-07]

3.20

protection en cas de défaut

protection contre les chocs électriques dans des conditions de premier défaut

[SOURCE: IEC 60050-195:2021, 195-06-02]

3.21

double isolation

isolation comprenant à la fois une isolation principale et une isolation supplémentaire

[SOURCE: IEC 60050-195:2021, 195-06-08]

3.22

isolation renforcée

isolation assurant un degré de protection contre les chocs électriques équivalant à celui d'une double isolation

Note 1 à l'article: L'isolation renforcée peut comporter plusieurs couches qui ne peuvent pas être soumises aux essais séparément en tant qu'isolation principale ou isolation supplémentaire.

[SOURCE: IEC 60050-195:2021, 195-06-09]

3.23

impédance de protection

composant ou ensemble de composants dont l'impédance et la conception sont telles qu'elles assurent la limitation du courant de contact en régime établi et de la charge électrique à des niveaux non dangereux

[SOURCE: IEC 60050-195:2021, 195-06-34]

3.24

luminaire de classe I

luminaire dans lequel la protection contre les chocs électriques ne repose pas uniquement sur l'isolation principale, mais qui comporte une mesure de sécurité supplémentaire sous la forme de moyens de raccordement des parties conductrices accessibles au conducteur de protection relié au câblage fixe de l'installation (mise à la terre), d'une manière telle que les parties conductrices accessibles ne puissent devenir des parties actives dangereuses en cas de défaillance de l'isolation principale

Note 1 à l'article: Pour un luminaire destiné à être utilisé avec un câble ou un cordon souple, ces moyens comprennent un conducteur de protection faisant partie du cordon ou du câble souple.

Note 2 à l'article: Les luminaires de classe I peuvent comporter des parties à double isolation ou à isolation renforcée.

Note 3 à l'article: Les luminaires de classe I peuvent avoir des parties dans lesquelles la protection contre les chocs électriques repose sur leur fonctionnement en très basse tension de sécurité (TBTS) ou en très basse tension de protection (TBTP).

3.25

luminaire de classe II

luminaire dans lequel la protection contre les chocs électriques ne repose pas uniquement sur l'isolation principale et qui comporte des mesures supplémentaires de sécurité, telles que la double isolation ou l'isolation renforcée, ces luminaires ne comportant aucun moyen de protection reposant sur la mise à la terre ou sur les conditions de l'installation

Note 1 à l'article: Un luminaire de classe II peut être de l'un des types suivants:

- a) luminaire comportant une enceinte en matériau isolant, durable et pratiquement continue, enveloppant toutes les parties métalliques, à l'exception de petites pièces, telles que les plaques signalétiques, les vis et les rivets, qui sont séparées des parties actives dangereuses par une isolation au moins équivalente à l'isolation renforcée. Un tel luminaire est appelé luminaire de classe II à enveloppe isolante;
- b) luminaire ayant une enveloppe métallique pratiquement continue isolée des parties actives dangereuses par une isolation au moins équivalente à une double isolation ou une isolation renforcée. Un tel luminaire est appelé luminaire de classe II à enveloppe métallique;
- c) luminaire constitué de la combinaison des types a) et b) ci-dessus.

Note 2 à l'article: L'enveloppe d'un luminaire de classe II à enveloppe isolante peut constituer une partie ou l'ensemble de l'isolation supplémentaire ou de l'isolation renforcée.

Note 3 à l'article: Si une mise à la terre fonctionnelle est prévue pour faciliter l'amorçage ou pour des raisons de CEM, mais n'est pas reliée à une partie métallique accessible, le luminaire est toujours réputé appartenir à la classe II. Les parties métalliques accessibles conformes à la spécification IEC appropriée pour les lampes ainsi que les autres parties métalliques qui ne sont pas normalement mises à la terre ni normalement accessibles pendant une utilisation normale ne sont pas considérées comme des parties conductrices pouvant causer un choc électrique, sauf si les essais de l'Annexe A montrent qu'elles sont des parties actives dangereuses.

Note 4 à l'article: Si un luminaire à double isolation ou à isolation renforcée pour toutes ses parties, ou les deux, comporte une borne de terre de protection ou un contact de terre de protection, il appartient à la classe I. Cependant, un luminaire fixe de classe II peut comporter une borne ou un contact intérieur qui assure la continuité électrique (par exemple pour un repiquage ou une ligne traversante) d'un conducteur de terre de protection.

Note 5 à l'article: Les luminaires de classe II peuvent avoir des parties dans lesquelles la protection contre les chocs électriques repose sur leur fonctionnement en très basse tension de sécurité (TBTS) ou en très basse tension de protection (TBTP).

3.26

luminaire de classe III

luminaire dans lequel la protection contre les chocs électriques repose sur son alimentation d'une très basse tension de sécurité (TBTS) ou d'une très basse tension de protection (TBTP) et dans lequel ne sont pas générées des tensions supérieures à celles autorisées pour la TBTS ou la TBTP

Note 1 à l'article: Un équipement source d'alimentation (PSE) de source d'énergie ES1 satisfaisant aux exigences de l'IEC 62368-3:2017 peut être considéré comme une TBTS.

3.27

température ambiante assignée maximale

t_a

température assignée à un luminaire par le fabricant comme étant la température ambiante la plus élevée que le luminaire peut supporter en fonctionnant dans les conditions normales

Note 1 à l'article: Cela n'exclut pas le fonctionnement temporaire à une température ne dépassant pas ($t_a + 10$) °C.

3.28

température de fonctionnement maximale assignée

t_c

<d'un appareillage de commande ou d'un condensateur> température maximale admissible pouvant survenir à la surface extérieure du composant (à l'emplacement indiqué, s'il est marqué) dans les conditions normales de fonctionnement à la tension assignée ou à la valeur maximale de la plage de tensions assignée

3.29

température de fonctionnement maximale assignée

t_w

<d'un enroulement d'appareillage de commande> température d'enroulement assignée par le fabricant comme étant la température maximale à laquelle un appareillage de commande électronique est présumé pouvoir fonctionner correctement pendant au moins 10 ans en service continu

[SOURCE: IEC 61347-1:2015, 3.17, modifié – "appareillage de commande de lampe, en 50 Hz/60 Hz," a été remplacé par "appareillage de commande électronique".]

3.30

ballast

ensemble inséré entre l'alimentation et au moins une lampe à décharge et qui, au moyen d'une inductance, d'une capacité ou d'une résistance, seule ou en combinaison, sert principalement à limiter le courant de la ou des lampes à décharge à la valeur exigée

Note 1 à l'article: Un ballast peut aussi comporter un transformateur de la tension d'alimentation et des dispositifs qui contribuent à fournir la tension d'amorçage et le courant de préchauffage, empêcher tout amorçage à froid, réduire l'effet stroboscopique, corriger le facteur de puissance et supprimer les perturbations radioélectriques.

[SOURCE: IEC 60050-845:2020, 845-28-044]

3.31

convertisseur abaisseur électronique

appareil inséré entre l'alimentation et une ou plusieurs lampes tungstène-halogène ou autres lampes à incandescence, qui a pour fonction d'alimenter la ou les lampes à leur tension assignée, généralement à haute fréquence.

Note 1 à l'article: Cet appareil peut être constitué d'un ou de plusieurs éléments séparés, et il peut inclure des dispositifs pour la gradation, la correction du facteur de puissance et la suppression des perturbations radioélectriques

[SOURCE: IEC 61347-2-2:2011, 3.1, modifié – La deuxième partie de la définition a été incluse en tant que Note à l'article.]

3.32

appareillage de commande indépendant

appareillage de commande constitué d'un ou de plusieurs éléments séparés, conçu de façon à pouvoir être monté séparément, en dehors d'un luminaire, avec une protection correspondant au marquage d'un appareillage de commande et sans enveloppe supplémentaire

Note 1 à l'article: Il peut se composer d'un appareillage de commande intégré logé dans une enceinte appropriée assurant toute la protection nécessaire correspondant à son marquage.

[SOURCE: IEC 60050-845:2020, 845-28-055, modifié – "appareillage de commande de lampe" a été remplacé par "appareillage de commande".]

3.33

composant

partie constitutive d'un luminaire ne pouvant être fractionnée matériellement sans perdre sa fonction

EXEMPLE Modules LED, starters, batteries, appareillage de commande auxiliaires.

Note 1 à l'article: Les lampes ne sont pas considérées comme des composants.

[SOURCE: IEC 60050-151:2001, 151-11-21, modifié – "dispositif" a été remplacé par "luminaire", "particulière" a été supprimée, les exemples et la Note à l'article ont été ajoutés.]

3.34

composant encastré

composant conçu pour être intégré à un luminaire, un boîtier, une enceinte ou analogue, et non destiné à être monté à l'extérieur d'un luminaire

[SOURCE: IEC 60050-845:2020, 845-27-062, modifié – "module LED" a été remplacé par "composant" et "former une partie remplaçable intégrée" a été remplacé par "être intégré".]

3.35

composant remplaçable

composant du luminaire qui peut être remplacé à la main ou à l'aide d'outils courants disponibles, pour la réparation ou la mise à niveau du luminaire, ou composant accessible dans le luminaire pour le réglage de son fonctionnement

EXEMPLE Batteries, appareillage de commande avec caractéristique de sortie réglable, dispositifs de détection de présence, fusibles, starters remplaçables.

Note 1 à l'article: Les sources de lumière peuvent également être considérées comme des composants remplaçables, mais dans le domaine d'application du présent document, les exigences de remplaçabilité des sources de lumière sont actuellement traitées séparément. Les lampes sont normalement toujours considérées comme des sources de lumière remplaçables.

3.36

composant non remplaçable

composant qui est une partie non remplaçable du luminaire soit parce qu'il ne peut pas être remplacé ou accessible pour un réglage sans casser ou détruire le luminaire soit parce qu'il est encastré sous une enveloppe fixée par un moyen de fixation conçu pour être utilisé une seule fois et qui ne peut pas être ouverte

3.37

composant non remplaçable par l'utilisateur final

composant dont le remplacement ou le réglage ne peut être effectué que par le fabricant, son agent de maintenance ou une personne qualifiée équivalente

3.38**douille intégrée**

partie d'un luminaire qui porte la lampe électrique, assure le raccordement électrique de celle-ci, et qui est conçue comme un constituant du luminaire

[SOURCE: IEC 60050-845:2020, 845-28-026]

3.39**vasque translucide**

partie du luminaire transmettant la lumière et pouvant également procurer la protection des lampes et des autres composants incluant les diffuseurs, les panneaux optiques et les éléments similaires de contrôle de la lumière

3.40**câble de l'installation fixe**

câble qui appartient à l'installation fixe à laquelle le luminaire est raccordé

Note 1 à l'article: Les câbles de l'installation fixe peuvent être introduits dans le luminaire et raccordés à des bornes, y compris les bornes des douilles, des interrupteurs et des accessoires analogues.

3.41**connecteur**

ensemble destiné à relier électriquement à volonté un câble souple à un luminaire comprenant deux parties: un connecteur comportant des contacts tubulaires faisant corps avec le câble souple d'alimentation ou destinés à lui être relié, et un socle de connecteur équipé de contacts à broches et qui est la partie incorporée ou fixée au luminaire

3.42**câblage externe**

câbles généralement à l'extérieur du luminaire, mais fournis avec celui-ci

Note 1 à l'article: Le câblage externe peut être utilisé pour raccorder le luminaire à l'alimentation, à d'autres luminaires ou à un appareillage de commande externe quelconque.

Note 2 à l'article: Le câblage externe ne se trouve pas nécessairement sur toute sa longueur à l'extérieur du luminaire.

3.43**câblage interne**

câbles généralement placés à l'intérieur du luminaire, et fournis avec celui-ci, et qui assurent le raccordement entre les bornes pour câblage externe ou les cordons d'alimentation et les bornes des douilles, des interrupteurs et des composants similaires

Note 1 à l'article: Le câblage interne ne se trouve pas nécessairement sur toute sa longueur à l'intérieur du luminaire.

3.44**matériau normalement inflammable**

matériau dont la température d'inflammation est d'au moins 200 °C et qui ne se déforme ni ne se ramollit à cette température

EXEMPLE Bois et matériaux à base de bois d'épaisseur supérieure à 2 mm.

Note 1 à l'article: La température d'inflammation et la résistance à la déformation et au ramollissement de matériaux normalement inflammables sont fondées sur les valeurs couramment acceptées et déterminées par une durée d'essai de 15 min.

3.45

surface facilement inflammable

matériau de surface qui ne peut être classé ni comme normalement inflammable ni comme non combustible

EXEMPLE Fibre de bois et matériaux à base de bois jusqu'à 2 mm d'épaisseur.

3.46

surface non combustible

matériau de surface incapable d'entretenir la combustion

Note 1 à l'article: Pour les besoins du présent document, les matériaux tels que le métal, le plâtre et le béton sont considérés comme des matériaux non combustibles.

3.47

matériau inflammable

matériau qui ne satisfait pas aux exigences de l'essai au fil incandescent du 15.3.3

3.48

TBT

très basse tension

tension qui ne dépasse pas 50 V en courant alternatif efficace ou 120 V en courant continu lisse entre conducteurs ou entre n'importe quel conducteur et la terre

Note 1 à l'article: "Lisse" est défini de façon conventionnelle pour une tension sinusoïdale lissée avec un taux d'ondulation ne dépassant pas 10 % de la valeur efficace: la valeur de crête maximale n'excède pas 140 V pour un système à courant continu lisse de 120 V nominale, 70 V pour un système à courant continu lisse de 60 V nominale et 35 V pour un système lisse de 30 V nominale.

Note 2 à l'article: Pour un courant continu interrompu, à des fréquences comprises entre 10 Hz et 200 Hz, le présent document applique une limite maximale de crête de 50 V pour la TBT, cette limite incluant une éventuelle ondulation. Pour des fréquences en dehors de cette plage, les limites du courant continu s'appliquent. Les exigences pour la plage de fréquences de 10 Hz à 200 Hz sont issues d'un rapport de recherche de 1936, intitulé "Electric Shock Effects of Frequency" (Effets de la fréquence sur les chocs électriques), publié par W.B. Kouwenhoven, D.R. Hooker et E.L. Lotz.

3.48.1

circuit TBTF

circuit très basse tension de fonctionnement

circuit électrique qui a une très basse tension pour des raisons fonctionnelles, mais qui ne répond pas aux exigences qui s'appliquent à un circuit TBTS ou à un circuit TBTP

Note 1 à l'article: Dans le présent document, le terme "TBTF" est utilisé lorsqu'un circuit TBTF est prévu.

3.48.2

circuit TBTS

circuit très basse tension de sécurité

circuit électrique dont la tension ne peut pas dépasser la valeur de la très basse tension

- dans des conditions normales et
- dans des conditions de premier défaut, y compris les défauts à la terre dans les autres circuits électriques

Note 1 à l'article: Dans le présent document, le terme "TBTS" est utilisé lorsqu'un circuit TBTS est prévu.

Note 2 à l'article: Une tension maximale inférieure à 50 V en courant alternatif en valeur efficace ou 120 V en courant continu lisse peut être spécifiée avec des exigences particulières, en particulier lorsqu'un contact direct avec les parties conductrices est admis.

[SOURCE: IEC 60050-195:2021, 195-06-28, modifié – "circuit très basse tension de sécurité" a été ajouté comme terme admis, "schéma" a été remplacé par "circuit", et la Note 1 à l'article a été remplacée par deux nouvelles Notes à l'article.]

3.48.3

circuit TBTP

circuit très basse tension de protection

circuit électrique dont la tension ne peut pas dépasser la valeur de la très basse tension

- dans des conditions normales et
- dans des conditions de premier défaut, à l'exception des défauts à la terre dans les autres circuits électriques

Note 1 à l'article: Dans le présent document, le terme "TBTP" est utilisé lorsqu'un circuit TBTP est prévu.

[SOURCE: IEC 60050-195:2021, 195-06-29, modifié – "protective extra-low-voltage circuit" a été ajouté comme terme admis, "schéma" a été remplacé par "circuit", et la Note 1 à l'article a été remplacée par une nouvelle Note 1 à l'article.]

3.49

tension de service

tension la plus élevée en valeur efficace qui peut se produire à travers une isolation dans des conditions d'alimentation assignées, les surtensions transitoires étant négligées, dans des conditions normales et anormales, y compris à vide

3.49.1

tension de sortie de crête maximale de service

\hat{U}_{out}

tension de service de crête répétitive maximale entre les bornes de sortie ou entre les bornes de sortie et la terre, lors de conditions de fonctionnement normales ou anormales et avec les surtensions transitoires négligées

[SOURCE: IEC 61347-1:2015, 3.45]

3.49.2

tension d'amorçage

tension de crête appliquée pour amorcer une lampe à décharge

[SOURCE: IEC 61347-1:2015, 3.46]

3.49.3

tension d'impulsion d'amorçage

tension d'amorçage de crête d'une durée totale $\leq 750 \mu\text{s}$ (somme de toutes les durées d'impulsion) en moins de 10 ms, la durée (largeur) de chaque impulsion étant mesurée à 50 % de la valeur de crête absolue maximale

Note 1 à l'article: Il convient que les formes d'onde d'impulsion d'amorçage, considérées comme une tension d'impulsion d'amorçage, ne contiennent pas de fréquence fondamentale supérieure à 30 kHz ou qu'elles soient généralement fortement amorties (après 20 μs il convient que le niveau de tension de crête soit inférieur à la moitié de la tension de crête maximale). Pour l'évaluation de la fréquence fondamentale, il convient de consulter l'Annexe E de l'IEC 60664-4:2005.

[SOURCE: IEC 61347-1:2015, 3.46.1]

3.49.4**tension de crête équivalente transformée** U_p

tension de crête de sortie transformée, qui est convertie pour la tension de crête la plus défavorable avec sa fréquence associée en une tension d'impulsion d'amorçage

Note 1 à l'article: La valeur de la tension de crête de sortie transformée équivalente déclarée est un paramètre essentiel pour la sélection des composants associés.

Note 2 à l'article: Voir 3.49.3.

[SOURCE: IEC 61347-1:2015, 3.47, modifié – Les notes 3 et 4 à l'article ont été supprimées.]

3.50**essai de type**

essai ou série d'essais ayant pour but de vérifier la conformité de la conception d'un produit donné aux exigences de la norme appropriée

3.51**échantillon pour essai de type**

échantillon consistant en une ou plusieurs unités similaires représentatives de la production, présenté par le fabricant ou le fournisseur responsable en vue de l'essai de type

3.52**à la main**

n'exigeant pas l'utilisation d'un outil

3.53**borne**

partie d'un luminaire ou d'un composant nécessaire au raccordement électrique à un conducteur

Note 1 à l'article: Voir l'Article 16 et l'Article 17.

3.54**repiquage**

système de raccordement au réseau d'alimentation de deux ou plusieurs luminaires dans lequel chaque conducteur d'alimentation entre dans la même borne et en ressort

Note 1 à l'article: Un conducteur d'alimentation peut être coupé pour faciliter les connexions à une borne (voir Figure 1).

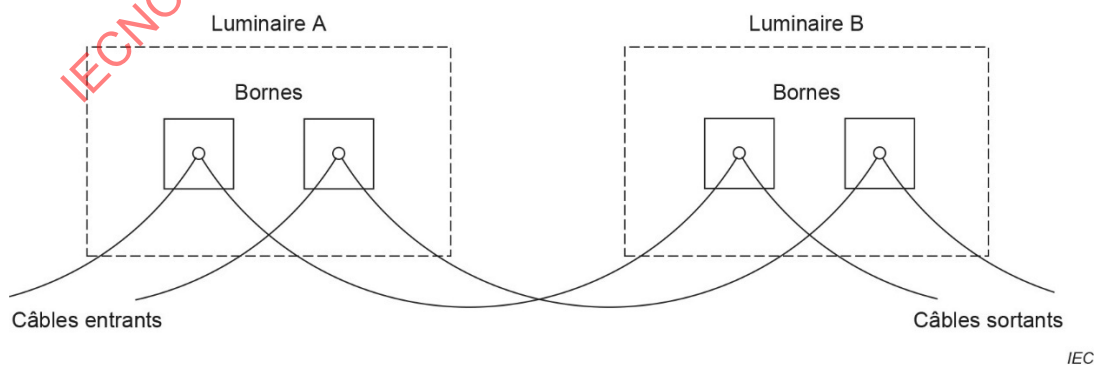

Figure 1 – Exemple de "repiquage" (passage en coupure)

3.55
ligne traversante

câblage qui traverse le luminaire, et destiné à l'interconnexion d'une rangée de luminaires

Note 1 à l'article: Certains pays n'admettent pas de raccords dans la ligne traversante.

Note 2 à l'article: Le luminaire peut ou non être connecté électriquement à la ligne traversante (voir Figure 2).

Note 3 à l'article: La ligne traversante peut assurer la continuité de différents types de systèmes de câblage, par exemple un système triphasé.

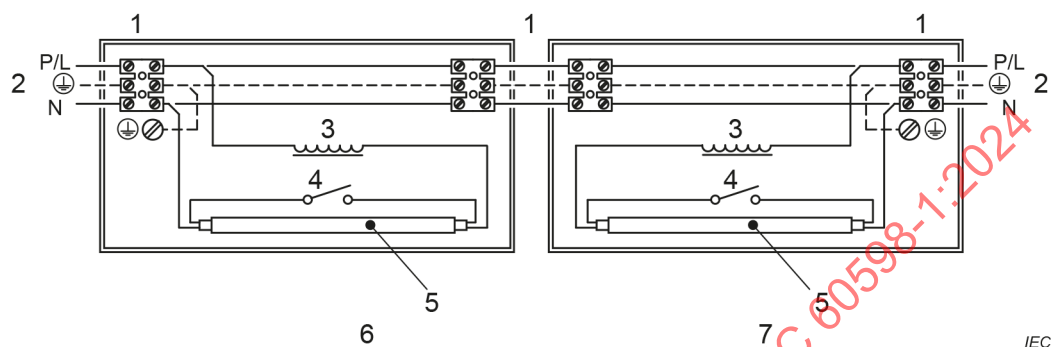

a) "ligne traversante" avec câblage interne raccordé électriquement à la ligne traversante

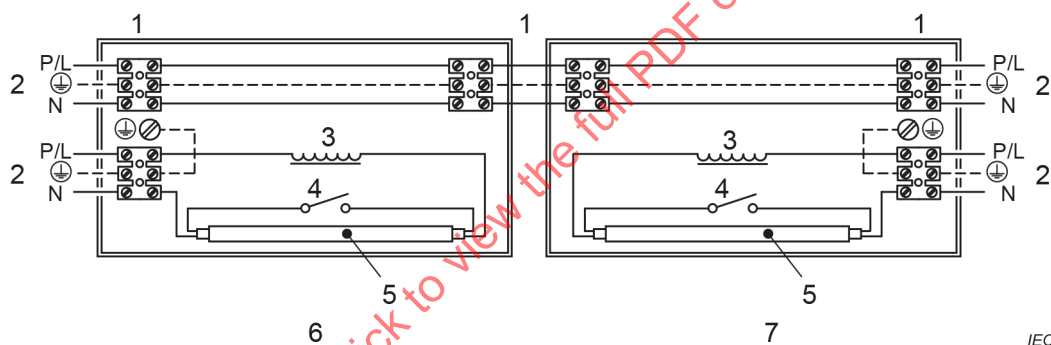

b) "ligne traversante" avec câblage interne séparé électriquement de la ligne traversante

Légende

- | | | | |
|---|--------------|---|-------------|
| 1 | bornes | 5 | lampe |
| 2 | alimentation | 6 | luminaire A |
| 3 | ballast | 7 | luminaire B |
| 4 | starter | | |

Figure 2 – Exemples de "lignes traversantes"

3.56
appareil d'amorçage

dispositif conçu pour assurer, seul ou en combinaison avec d'autres composants du circuit, les conditions électriques appropriées pour l'amorçage d'une lampe à décharge

[SOURCE: IEC 60050-845:2020, 845-28-041]

**3.57
starter**

dispositif, généralement pour les lampes fluorescentes, utilisé pour l'amorçage de la lampe à décharge en assurant le préchauffage nécessaire de la cathode et, en combinaison avec l'inductance série du ballast, provoque une tension de choc appliquée sur la lampe à décharge

Note 1 à l'article: L'élément de starter qui libère l'impulsion de tension d'amorçage peut être déclenché ou non déclenché.

[SOURCE: IEC 60050-845:2020, 845-28-042]

**3.58
amorçeur**

dispositif destiné à produire, seul ou en combinaison avec d'autres composants, des impulsions de tension destinées à amorcer une lampe à décharge sans assurer le préchauffage des électrodes

Note 1 à l'article: L'élément qui libère l'impulsion de tension d'amorçage peut être déclenché ou non déclenché.

[SOURCE: IEC 60050-845:2020, 845-28-043]

**3.59
bloc de jonction**

assemblage d'une ou plusieurs bornes dans ou sur un même corps en matériau isolant pour faciliter le raccordement entre conducteurs

**3.60
luminaire pour conditions sévères d'emploi**
luminaire conçu pour résister à des conditions mécaniques sévères

Note 1 à l'article: Le luminaire peut:

- être fixé de façon permanente, ou
- être fixé de façon temporaire sur une construction ou un support, ou
- être incorporé à un support ou un manche.

Note 2 à l'article: Les luminaires pour conditions sévères d'emploi sont destinés à être utilisés lorsque des conditions sévères se produisent normalement, ou lorsqu'un éclairage provisoire est exigé, par exemple dans des bâtiments en construction, des ateliers industriels et des applications similaires.

[SOURCE: IEC 60050-845:2020, 845-30-009]

**3.61
système de contact électromécanique**

système de connexion intérieur au luminaire par lequel la partie principale portant la douille est connectée électriquement et mécaniquement à la plaque de base ou au dispositif de suspension

Note 1 à l'article: La Figure 3 décrit le système de contact électromécanique. Les exigences des 7.11.6 et 9.2.1 s'appliquent comme telles. En effet, dans la situation décrite, la plaque de base et le châssis de l'appareillage de commande sont uniques et non interchangeables; la plaque de base n'a pas besoin d'être marquée avec le courant assigné de la connexion électrique, comme cela est spécifié en 6.2.

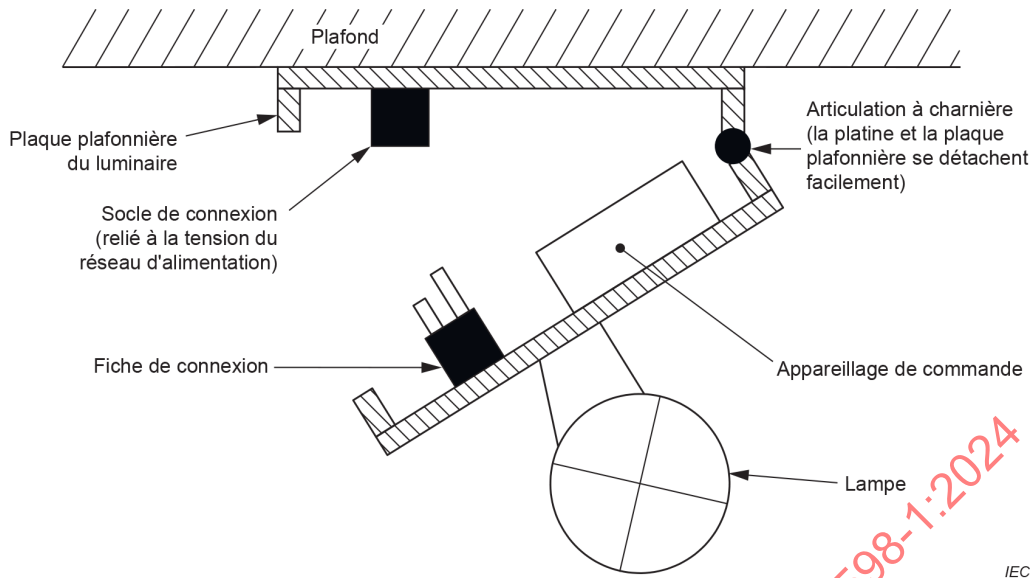

Figure 3 – Exemple de système de contact électromécanique avec connexion fiche ou socle

Note 2 à l'article: Le système peut comporter ou non un appareil de réglage.

Note 3 à l'article: Le système peut être dédié à un concept de luminaire spécifique ou peut fournir la connexion de plusieurs types de luminaires.

3.62 surface de montage

partie du bâtiment, meuble ou d'une autre structure à laquelle un luminaire en utilisation normale est fixé ou suspendu, ou sur laquelle il repose ou est placé, et qui supporte ou est destinée à supporter le luminaire

Note 1 à l'article: Les rails d'éclairage, les parties de luminaires, les appareillages de commande, les plaques de montage ou autres corps ne sont pas considérés comme une surface de montage.

3.63 composant intégré

composant constituant une partie non remplaçable d'un luminaire et qui ne peut pas être soumis à l'essai séparément du luminaire

3.64 lampe intégrée lampe autoballastée

lampe électrique ne pouvant être démontée sans subir de dommage permanent, qui intègre un appareillage de commande, et tous les éléments complémentaires nécessaires pour l'amorçage et le fonctionnement stable de la source de lumière, conçue pour un raccordement direct à la source de tension d'alimentation

Note 1 à l'article: Le composant source de lumière d'une lampe intégrée n'est pas remplaçable.

Note 2 à l'article: Le composant ballast fait partie de la lampe intégrée; il ne fait pas partie du luminaire.

[SOURCE: IEC 60050-845:2020, 845-27-009, modifié – Le deuxième terme privilégié "lampe autoballastée" et les Notes à l'article ont été ajoutés.]

3.65**semi-luminaire**

unité similaire à une lampe intégrée, mais conçue pour utiliser une source de lumière remplaçable et/ou un appareil d'amorçage remplaçable

Note 1 à l'article: Le composant ballast n'est pas remplaçable et n'est pas éliminé à chaque remplacement d'une source de lumière.

Note 2 à l'article: Une douille est exigée pour une connexion à l'alimentation.

[SOURCE: IEC 60050-845:2020, 845-30-002]

3.66**appareillage de commande indépendant enfichable**

appareillage de commande indépendant équipé d'une fiche intégrée en tant que moyen de connexion à l'alimentation électrique

3.67**luminaire monté sur prise de courant réseau**

luminaire équipé d'une prise de courant intégrée en tant que moyen à la fois de montage et de connexion à l'alimentation électrique

3.68**luminaire à pince**

assemblage intégré d'un luminaire et d'une pince à ressort élastique permettant d'immobiliser le luminaire d'une seule main, sur sa surface de montage

3.69**connecteur de lampe**

dispositif comportant des contacts électriques isolés et montés sur des conducteurs souples, qui assure la liaison de la lampe électrique à l'alimentation, mais non sa fixation mécanique

[SOURCE: IEC 60050-845:2020, 845-28-035, modifié – Le premier terme privilégié "connecteur" a été supprimé.]

3.70**socle de prise de courant réseau**

accessoire équipé d'alvéoles, conçu pour recevoir les broches ou languettes d'une fiche de prise de courant réseau et équipé de bornes pour la connexion de câbles ou cordons

3.71**appareillage de commande**

ensemble inséré entre l'alimentation électrique et au moins une source de lumière, qui permet d'alimenter la ou les sources de lumière avec sa ou ses tension ou courant assignés, et qui peut comprendre un ou plusieurs composants distincts

Note 1 à l'article: Un appareillage de commande peut comporter des moyens d'allumage et de gradation, de correction du facteur de puissance et de suppression des perturbations radioélectriques, ainsi que d'autres fonctions de commande.

Note 2 à l'article: Un appareillage de commande peut se composer d'une alimentation électrique et d'un ensemble de commande.

Note 3 à l'article: Un appareillage de commande peut être intégré partiellement ou totalement dans la source de lumière.

Note 4 à l'article: Les termes anglais "control gear" et "controlgear" sont interchangeables. Les normes IEC utilisent couramment le terme anglais "controlgear".

[SOURCE: IEC 60050-845:2020, 845-28-048.]

3.72

lampe factice

appareil incorporant un culot qui est conforme aux exigences de la série IEC 60061, le cas échéant

3.73

lampe autoprotégée

lampe à incandescence à halogènes ou lampe aux halogénures métalliques pour laquelle aucun écran de protection du luminaire n'est nécessaire pour assurer une protection contre l'émission de rayons ultraviolets ou une rupture de la lampe

[SOURCE: IEC 60050-845:2020, 845-27-094]

3.74

câble externe souple

cordon externe souple

câble ou cordon souple pour connexion externe au circuit d'entrée ou de sortie, fixé au luminaire ou assemblé avec ce dernier selon la méthode de fixation de type X, Y ou Z

3.74.1

fixation de type X

méthode de fixation du câble ou du cordon de façon telle qu'il puisse être facilement remplacé

Note 1 à l'article: Le câble ou le cordon souple peut être spécialement conçu et uniquement disponible chez le fabricant ou son agent de maintenance.

Note 2 à l'article: Un câble ou cordon spécialement conçu peut également intégrer une partie du luminaire.

3.74.2

fixation de type Y

méthode de fixation du câble ou du cordon telle que son remplacement ne puisse être réalisé que par le fabricant, son agent de maintenance ou une personne qualifiée équivalente

Note 1 à l'article: Une fixation de type Y peut être utilisée avec un câble ou un cordon souple, spécial ou ordinaire.

3.74.3

fixation de type Z

méthode de fixation du câble ou du cordon telle qu'il ne puisse être remplacé sans casser ou détruire le luminaire

3.75

mise à la terre

3.75.1

mise à la terre de protection

action de mettre à la terre à des fins de sécurité électrique

[SOURCE: IEC 60050-195:2021, 195-01-11, modifié – Le premier terme privilégié "mise à la terre" a été ajouté.]

3.75.2

terre fonctionnelle

action de mettre à la terre pour des raisons autres que la sécurité électrique

Note 1 à l'article: La mise à la terre fonctionnelle peut être utilisée pour faciliter l'amorçage d'une lampe ou pour éviter les perturbations radioélectriques.

[SOURCE: IEC 60050-195:2021, 195-01-13, modifié – La Note 1 à l'article a été ajoutée.]

3.76

câble d'interconnexion

câble ou ensemble de câbles entre deux parties essentielles d'un luminaire, livré par le fabricant de luminaires, et qui peut être considéré comme faisant partie intégrante du luminaire

Note 1 à l'article: Un ensemble de câbles peut contenir une combinaison de différents câbles, par exemple pour fournir la tension d'alimentation, la mise à la terre, les tensions de démarrage et de service, les connexions fonctionnelles de câbles. Des exemples d'applications sont: entre un luminaire et un coffret pour appareillage d'alimentation, un boîtier de montage ou un connecteur installé sur un système d'alimentation par rail.

3.77

férule

accessoire mécanique, généralement un tube rigide, destiné à maintenir l'extrémité dénudée d'un câble

3.78

catégorie de surtension

catégorie de tenue aux chocs

chiffre définissant une condition de surtension transitoire

Note 1 à l'article: Les catégories de surtensions I, II, III et IV sont utilisées.

Note 2 à l'article: L'explication suivante est issue de l'IEC 60364-4-443 (supprimée).

a) But de la classification des catégories de tenue aux chocs

Les catégories de tenue aux chocs servent à différencier les différents degrés de disponibilité des équipements compte tenu des attentes exigées en matière de continuité de service et de tolérance des risques de défaillance.

En sélectionnant les niveaux de tenue aux chocs de l'isolation des équipements, la coordination peut être réalisée pour l'installation complète en réduisant le risque de défauts à un niveau acceptable qui sert de base dans la maîtrise de la surtension.

Un chiffre plus élevé désignant la catégorie de tenue aux chocs indique une tenue aux chocs de l'équipement plus élevée, et permet un plus grand choix de méthodes pour la maîtrise de la surtension.

Le concept de catégorie de tenue aux chocs est utilisé pour les équipements directement alimentés par le réseau.

b) Description des catégories de tenue aux chocs

Un équipement de catégorie de tenue aux chocs I est un équipement destiné à être connecté aux installations fixes électriques des bâtiments. Des moyens de protection sont pris à l'extérieur de l'équipement – soit dans l'installation fixe, soit entre l'installation fixe et l'équipement – pour limiter les surtensions transitoires à un niveau précis.

Un équipement de catégorie de tenue aux chocs II est un équipement destiné à être connecté aux installations fixes électriques des bâtiments.

Un équipement de catégorie de tenue aux chocs III est un équipement qui constitue une partie des installations fixes électriques et des autres équipements dont le degré de disponibilité attendu est plus élevé.

Un équipement de catégorie de tenue aux chocs IV est destiné à être utilisé à proximité ou dans les installations électriques des bâtiments en amont du tableau de distribution.

3.79

circuits et caractéristiques des circuits

3.79.1

circuit primaire

circuit qui est directement connecté au réseau d'alimentation

Note 1 à l'article: Cela comprend, par exemple, les moyens de connexion au réseau d'alimentation, les enroulements primaires des transformateurs, les moteurs et les autres dispositifs absorbant de l'énergie.

[SOURCE: IEC 60950-1:2005, 1.2.8.4 (supprimé), modifié – "réseau d'alimentation en courant alternatif" a été remplacé par "réseau d'alimentation", la deuxième partie de la définition a été incluse en tant que Note 1 à l'article et la note existante a été supprimée.]

3.79.2 circuit secondaire

circuit qui n'est pas relié directement à un circuit primaire et qui est alimenté par l'intermédiaire d'un transformateur, d'un convertisseur ou d'un dispositif équivalent ou par l'intermédiaire d'une batterie

Note 1 à l'article: Dans les autotransformateurs, bien qu'ils aient une connexion directe à un circuit primaire, la partie connectée du transformateur constitue également un circuit secondaire au sens de la présente définition.

Note 2 à l'article: Les transitoires de réseau dans un tel circuit sont atténués par les enroulements primaires correspondants. Les ballasts inductifs réduisent également la valeur de la tension des transitoires de réseau. En conséquence, les composants situés après un circuit primaire ou après un ballast inductif peuvent être adaptés à une catégorie de surtension un niveau plus bas, voir l'Annexe Q.

[SOURCE: IEC 60950-1:2005, 1.2.8.5 (supprimé), modifié – "dispositif d'isolement équivalent" a été remplacé par "dispositif équivalent" et la note a été remplacée par deux nouvelles Notes à l'article.]

3.80 courant de contact

courant électrique passant dans le corps humain ou dans celui d'un animal lorsque ce corps est en contact avec une ou plusieurs parties accessibles d'une installation ou de matériels

Note 1 à l'article: Dans le présent document, le corps humain est représenté par les réseaux de la Figure G.2 ou de la Figure G.3.

[SOURCE: IEC 60050-195:2021, 195-05-21, modifié – La Note à l'article a été ajoutée.]

3.81 courant dans le conducteur de protection

courant électrique apparaissant dans un conducteur de protection, tel qu'un courant de fuite ou courant électrique dû à un défaut d'isolation

Note 1 à l'article: Ce courant peut avoir une influence sur le fonctionnement des RCD (appareils de protection du courant résiduel) connectés dans le même circuit.

[SOURCE: IEC 60050-195:2021, 195-05-22, modifié – La Note 1 à l'article a été ajoutée.]

3.82 brûlure électrique

brûlure de la peau ou d'un organe, causée par le passage superficiel ou en profondeur d'un courant électrique

[SOURCE: IEC 60050-195:2021, 195-03-01]

3.83 moyens de réglage

partie du luminaire, qui peut être le compartiment lampe, considérée sans ambiguïté comme destinée à être manipulée par l'utilisateur du luminaire, pour modifier la direction du flux lumineux par exemple

3.84**volume d'accessibilité au toucher**

zone s'étendant entre tout point de la surface où les personnes se tiennent et circulent habituellement, et la limite qu'une personne peut atteindre avec la main, dans toutes les directions, sans moyen auxiliaire

Note 1 à l'article: L'IEC 60364-4-41 comporte un dessin représentant la zone d'accessibilité. D'une manière générale, la hauteur est de 2,5 m à partir du plancher, et la distance dans toutes directions horizontales par rapport à l'emplacement auquel une personne peut se trouver, de 1,25 m.

[SOURCE: IEC 60050-195:2021, 195.06.12, modifié – La Note 1 à l'article a été remplacée par une nouvelle Note 1 à l'article.]

3.85**borne avec contact automatique de terre de protection intégré**

borne dont la connexion de mise à la terre est réalisée au moyen d'un contact intégré ou au moyen d'un contact auxiliaire sans opérations d'assemblage additionnelles (vissage par exemple) lorsqu'elle est installée

3.86**outil**

tournevis, pièce de monnaie ou tout autre objet pouvant être utilisé pour agir sur une vis ou des moyens de fixation similaires

3.87**cordon spécialement conçu**

câble ou cordon souple dont le remplacement avec un autre câble ou cordon non spécifique pourrait créer un danger ou diminuer la sécurité

3.88**luminaire réglable**

luminaire fixe dont la partie principale peut être orientée ou déplacée à l'aide de raccords, d'appareils à contrepoids, de tubes télescopiques ou d'appareils similaires, mais possédant un appareil (ou des appareils) de verrouillage manipulé(s) par un outil et qui n'est pas destiné à être réglé en cours d'utilisation

[SOURCE: IEC 60050-845:2020, 845-30-014]

3.89**source de lumière**

surface ou objet émettant de la lumière

Note 1 à l'article: Une source de lumière peut émettre de la lumière par elle-même (source primaire de lumière) ou ne pas émettre de lumière par elle-même (source secondaire de lumière).

Note 2 à l'article: Une source de lumière électrique peut être une lampe électrique, ou un module LED conçu pour être raccordé au moyen de bornes, connecteurs ou dispositifs analogues.

[SOURCE: IEC 60050-845:2020, 845-27-001, modifié – La Note 2 à l'article a été remplacée par une nouvelle Note 2 à l'article.]

3.89.1

source de lumière remplaçable

source de lumière conçue pour être remplacée par une personne qualifiée ou non qualifiée

Note 1 à l'article: Lorsqu'elle est intégrée à un luminaire, une source de lumière remplaçable peut être classée comme remplaçable, non remplaçable par l'utilisateur ou non remplaçable selon la conception du luminaire.

Note 2 à l'article: Tous les types de lampes équipées de culots de lampe sont considérés comme des sources de lumière remplaçables.

[SOURCE: IEC 60050-845:2020, 845-27-005, 27.005, modifié – La Note 2 à l'article a été ajoutée.]

3.89.2

source de lumière non remplaçable

source de lumière conçue pour être une partie non remplaçable du luminaire

Note 1 à l'article: Une source de lumière intégrée est toujours non remplaçable. Une source de lumière non remplaçable n'est pas toujours une source de lumière intégrée.

Note 2 à l'article: La non-remplaçabilité peut être le résultat de la conception du luminaire.

[SOURCE: IEC 60050-845:2020, 845-27-006]

3.89.3

source de lumière non remplaçable par l'utilisateur

source de lumière conçue par le fabricant pour être remplacée uniquement par un agent d'entretien, ou une personne qualifiée similaire

Note 1 à l'article: Lorsqu'elle est intégrée à un luminaire, une source de lumière non remplaçable par l'utilisateur peut être classée comme non remplaçable selon la conception du luminaire.

[SOURCE: IEC 60050-845:2020, 845-27-007]

3.90

personne qualifiée

personne qualifiée en électricité

personne ayant la formation et l'expérience appropriées pour lui permettre de percevoir les risques et d'éviter les dangers que peut présenter l'électricité

[SOURCE: IEC 60050-195:2021, 195-04-01]

3.91

personne ordinaire

personne qui n'est ni une personne qualifiée ni une personne avertie

Note 1 à l'article: La définition d'une "personne avertie ou personne qualifiée en électricité" est la suivante: personne suffisamment informée ou surveillée par des personnes qualifiées en électricité pour lui permettre de percevoir les risques et d'éviter les dangers que peut présenter l'électricité.

[SOURCE: IEC 60050-195:2021, 195-04-03, modifié – La Note 1 à l'article a été ajoutée.]

3.92

borne de contrôle

connexions, autres que les bornes d'alimentation électrique, vers l'appareillage électronique qui sont utilisées pour échanger des informations avec l'appareillage

Note 1 à l'article: Les bornes d'alimentation de l'appareillage peuvent aussi être utilisées pour échanger des informations avec l'appareillage.

3.93**réseau**

système de distribution de l'alimentation en courant alternatif ou en courant continu (externe aux matériels) qui fournit une alimentation fonctionnelle au luminaire et dont la tension correspond à la bande basse tension (BT) à l'exclusion de la bande très basse tension (TBT)

Note 1 à l'article: Les limites des bandes de tensions BT et TBT sont spécifiées dans l'IEC 61140:2016, Tableau 1.

[SOURCE: IEC 60664-1:2020, 3.1.2, modifié – "réseau d'alimentation (secteur)" a été remplacé par "réseau", "aux matériels" a été remplacé par "au luminaire", "et dont la tension correspond à la bande basse tension (BT) à l'exclusion de la bande très basse tension (TBT)" a été ajouté et la Note 1 à l'article a été remplacé par une nouvelle Note 1 à l'article.]

3.94**câbles de raccordement****sorties**

câblage interne des luminaires destinés à être connectés au câble de l'installation fixe par des bornes séparées qui se trouvent dans le luminaire ou la boîte de connexion

3.95**valeur assignée**

valeur d'une grandeur, utilisée à des fins de spécification, établie dans des conditions d'essai normatives telles que déclarées par le fabricant ou le vendeur responsable

[SOURCE: IEC 62504:2014, 3.33, modifié – La Note 1 à l'article a été supprimée.]

3.96**puissance d'entrée**

puissance électrique consommée par le luminaire

3.97**fonction de flux lumineux constant**

fonction par laquelle le courant passant dans une source de lumière est progressivement augmenté au cours de la durée de vie afin de compenser la dégradation progressive du flux lumineux de la source de lumière qui peut être présumée se produire

Note 1 à l'article: Les fonctions de flux lumineux constant peuvent être régulées par un algorithme logiciel programmé fondé sur la dégradation progressive attendue du flux lumineux ou sur la rétroaction d'un capteur connecté tel qu'une cellule photoélectrique.

3.98**tension en courant continu interrompu**

signal de courant continu qui varie entre zéro et un niveau spécifique à une certaine fréquence, le temps pendant lequel le signal se trouve à ce niveau spécifique pouvant varier au cours d'une période

3.99**PSE****équipement source d'alimentation**

matériel produisant de l'énergie pour alimenter d'autres matériels par le biais d'un câblage de communication informatique assurant une source d'énergie ES1 selon la série IEC 62368

3.100**PoE****alimentation électrique par câble Ethernet**

alimentation d'un dispositif par un PSE conformément à l'IEC 62368-3, par le biais d'un câblage Ethernet à paires torsadées, y compris les connecteurs appropriés

Note 1 à l'article: Les exemples types de câbles sont les câbles CAT 5 et CAT 7.

Note 2 à l'article: L'abréviation "PoE" est dérivée du terme anglais développé correspondant "power over Ethernet".

3.101**USB****bus série universel**

interface de communication comprenant des connecteurs appropriés pour les dispositifs de communication et d'alimentation, conformément à la série IEC 62680

Note 1 à l'article: Un luminaire de classe III est un exemple de dispositif comme cela est indiqué dans la définition.

Note 2 à l'article: Plusieurs versions existent (USB 1.0, 2.0, 3.0).

Note 3 à l'article: L'abréviation "USB" est dérivée du terme anglais développé correspondant "universal serial bus".

3.102**câblage de communication informatique**

tout câble destiné au transfert de données, équipé d'un connecteur défini par une norme de l'industrie, et qui permet le transfert de puissance en courant continu entre les matériels, même en l'absence de communication

EXEMPLE Câbles USB ou Ethernet.

3.103**luminaire monté sur rail**

luminaire conçu pour être utilisé sur un système de rail, pour lequel la liaison électrique et mécanique est assurée soit par un adaptateur soit par un connecteur de luminaire associé à un dispositif de suspension du luminaire

Note 1 à l'article: Les luminaires de classe I et de classe II peuvent être utilisés avec des systèmes de rails ou zones de classe I, les luminaires de classe III peuvent être utilisés uniquement avec des systèmes de rails ou zones de classe III.

Note 2 à l'article: Les luminaires montés sur rail peuvent comporter des dispositifs d'interface de commande.

3.104**borne à trou**

borne dans laquelle le conducteur est introduit dans un trou ou dans un logement, où il est serré sous l'extrémité de la vis ou des vis

Note 1 à l'article: La pression de serrage peut être appliquée directement par l'extrémité de la vis ou au moyen d'un organe de serrage intermédiaire auquel la pression est appliquée par l'extrémité de la vis.

Note 2 à l'article: Des exemples de bornes à trou sont représentés à la Figure 46.

3.105**borne à serrage sous tête de vis**

borne dans laquelle le conducteur est serré sous la tête de vis.

Note 1 à l'article: La pression de serrage peut être appliquée directement par la tête de la vis ou au moyen d'un organe intermédiaire, tel qu'une rondelle, une plaquette ou un appareil d'arrêt de brins.

Note 2 à l'article: Des exemples de bornes à serrage sous tête de vis sont représentés à la Figure 47.

3.106**borne à goujon fileté**

borne dans laquelle le conducteur est serré sous un écrou

Note 1 à l'article: La pression de serrage peut être appliquée directement par un écrou de forme convenable ou par l'intermédiaire d'une pièce telle qu'une rondelle, une plaquette de serrage ou un appareil d'arrêt de brins.

Note 2 à l'article: Des exemples de bornes à goujon fileté sont représentés à la Figure 47.

3.107**borne à plaquette**

borne dans laquelle le conducteur est serré sous une plaquette au moyen d'au moins deux vis ou écrous

Note 1 à l'article: Des exemples de bornes à plaquette sont représentés à la Figure 48.

3.108**borne pour cosses et barrettes**

borne à serrage sous tête de vis ou borne à goujon fileté prévue pour le serrage d'une cosse ou d'une barrette au moyen d'une vis ou d'un écrou

Note 1 à l'article: Des exemples de bornes pour cosses et barrettes sont représentés à la Figure 49.

3.109**borne à capot taraudé**

borne dans laquelle le conducteur est serré contre le fond d'une fente par une rondelle de forme appropriée placée sous l'écrou, par un téton central si l'écrou est un capot taraudé, ou par un autre moyen aussi efficace pour transmettre la pression de l'écrou au conducteur à l'intérieur de la fente

Note 1 à l'article: Des exemples de bornes à capot taraudé sont représentés à la Figure 50.

3.110**borne sans vis**

pièce exigée pour la réalisation de connexions dans un circuit électrique par des moyens mécaniques sans vis

3.111**connexion permanente**

connexion destinée à être réalisée une fois seulement avec le même fil

EXEMPLE Guipage ou sertissage de fils.

3.112**connexion démontable**

connexion qui permet de connecter ou de déconnecter plusieurs fois des faisceaux équipés ou des conducteurs

EXEMPLE Broches, languettes et prises femelles ou certaines bornes du type à serrage par ressort.

3.113**faisceau équipé**

conducteur fixé avec des pièces auxiliaires, habituellement au moyen d'une connexion permanente

3.114

conducteur non préparé

conducteur sans préparation spéciale ou sans pièce auxiliaire

Note 1 à l'article: L'enveloppe isolante peut, toutefois, être enlevée pour dénuder le conducteur.

Note 2 à l'article: L'expression "préparation spéciale" comprend l'étamage additionnel des brins du conducteur, l'utilisation de cosses, de broches ou languettes avec prise femelle, la formation d'œillets, etc., mais non la remise en forme du conducteur avant son introduction dans la borne, ni le toronnage des brins d'un conducteur toronné pour en consolider l'extrémité.

La soudure sans apport de métal, par chauffage des brins étamés d'un conducteur souple, n'est pas considérée comme une préparation spéciale.

3.115

courant d'essai

courant assigné à la borne, ou la connexion, par le fabricant

Note 1 à l'article: Quand la borne fait partie d'un composant, le courant d'essai doit être le courant assigné du composant.

3.116

luminaire fonctionnant sur batterie/EDLC

luminaire alimenté par des batteries rechargeables ou non ou par condensateur électrique à double couche (EDLC)

3.117

batterie

un ou plusieurs éléments équipés des dispositifs nécessaires pour l'emploi, par exemple boîtier, bornes, marquage et dispositifs de protection

[SOURCE: IEC 60050-482:2004, 482-01-04]

3.118

élément

unité fonctionnelle de base, consistant en un assemblage d'électrodes, d'électrolyte, de conteneur, de bornes et généralement de séparateurs, qui est une source d'énergie électrique obtenue par transformation directe d'énergie chimique

Note 1 à l'article: Voir pile et accumulateur.

[SOURCE: IEC 60050-482:2004, 482-01-01]

3.119

batterie remplaçable

batterie destinée à être remplacée par l'utilisateur

3.120

batterie/EDLC non remplaçable

batterie ou EDLC qui est une partie non remplaçable du luminaire soit parce qu'elle ne peut pas être remplacée sans casser ou détruire le luminaire soit parce qu'elle est encastrée sous une enveloppe fixée par une vis ou un moyen de fixation similaire conçu pour être utilisé une seule fois et qui ne peut pas être ouverte

3.121

batterie/EDLC non remplaçable par l'utilisateur

batterie ou EDLC qui ne peut être remplacée que par le fabricant, son agent de maintenance ou une personne qualifiée équivalente

3.122**pile-bouton**

petite pile ronde dont la hauteur totale est inférieure au diamètre et dont le système électrochimique ne contient pas de lithium

[SOURCE: IEC 60050-482:2004, 482-02-40, modifié – La définition a été adaptée pour inclure les piles à la place des éléments et pour différencier les piles au lithium et les piles sans lithium.]

3.123**pile au lithium**

petite pile ronde dont la hauteur totale est inférieure au diamètre et dont le système électrochimique contient du lithium

[SOURCE: IEC 60050-482:2004, 482-02-40, modifié – La définition a été adaptée pour inclure les piles à la place des éléments et pour différencier les piles au lithium et les piles sans lithium.]

3.124**EDLC****condensateur électrique à double couche**

condensateur utilisé pour exécuter la fonction d'une batterie

Note 1 à l'article: L'abréviation "EDLC" est dérivée du terme anglais développé correspondant "electric double-layer capacitor".

3.125**capacité assignée**

valeur de la capacité d'une batterie déterminée dans des conditions spécifiées et déclarée par le fabricant

[SOURCE: IEC 60050-482:2004, 482-03-15]

3.126**chargeur de batterie/d'EDLC**

dispositif pour charger des batteries ou des EDLC

3.127**système de charge**

circuits destinés à charger et qui peuvent équilibrer ou maintenir l'état de charge de la batterie

Note 1 à l'article: Les éléments fonctionnels du système de charge peuvent être répartis entre le chargeur, toute batterie détachable et le luminaire lui-même.

3.128**bloc de batteries amovible**

batterie qui est à l'intérieur d'une enveloppe séparée du luminaire et qui est destinée à être retirée du luminaire pour le chargement

3.129**élément pour usage général****pile pour usage général**

élément et pile disponibles auprès de plusieurs fabricants, par l'intermédiaire de plusieurs points de vente destinés à plusieurs produits de fabricants différents

EXEMPLE Batteries 12 V au plomb-acide de type automobile et piles alcalines AA, C et D non rechargeables.

3.130 **complètement chargé** à l'état de charge maximal

Note 1 à l'article: Pour les éléments et piles qui sont rechargeables, il s'agit de l'état de charge maximal admis par le système de charge.

Note 2 à l'article: L'état de charge maximal des batteries non rechargeables et des batteries qui sont rechargeables est spécifié dans les caractéristiques des sources artificielles du Tableau W.1.

4 Exigences générales

4.1 Généralités

4.1.1 Les luminaires doivent être conçus et construits de manière telle qu'en utilisation normale, ils fonctionnent sans compromettre la sécurité, et sans créer aucun danger pour les personnes ou l'environnement. En général, la conformité est vérifiée en réalisant tous les essais spécifiés.

4.1.2 Un luminaire doit être conforme à une partie de la série IEC 60598-2. Si cependant, une partie appropriée de la série IEC 60598-2 n'existe pas pour un luminaire ou un groupe de luminaires donné, la partie applicable la plus proche de la série IEC 60598-2 peut être utilisée comme guide pour les exigences et les essais.

Lorsque la conception d'un luminaire est telle que deux parties ou plus de la série IEC 60598-2 sont applicables, le luminaire doit être conforme aux deux ou à toutes les parties appropriées.

Les parties de la série IEC 60598-2, en se référant à un quelconque article du présent document, spécifient la limite dans laquelle cet article est applicable et l'ordre dans lequel les essais sont exécutés; elles comportent également des exigences complémentaires si besoin est.

L'ordre dans lequel les articles du présent document sont numérotés n'a aucune importance particulière, parce que l'ordre dans lequel leurs dispositions s'appliquent est déterminé, pour chaque type de luminaire ou groupe de luminaires, par la partie appropriée de la série IEC 60598-2. Chaque partie de la série IEC 60598-2 est indépendante et, par conséquent, ne comporte aucune référence aux autres parties de la série IEC 60598-2.

Lorsque les exigences d'un des articles du présent document sont évoquées dans des parties de la série IEC 60598-2 au moyen de la phrase "Les dispositions de l'Article X de la Partie 1 s'appliquent..." ou de la phrase "L'Article de la Partie 1 s'applique...", cela signifie que toutes les exigences de cet article du présent document s'appliquent, à l'exception de celles qui sont clairement inapplicables au type particulier de luminaire visé par cette partie de la série IEC 60598-2.

4.1.3 Sauf indication contraire, les termes "tension" et "courant" font référence aux valeurs efficaces.

4.2 Exigences d'essai générales et vérification

4.2.1 Les essais spécifiés dans le présent document sont des essais de type. Pour la définition d'un "essai de type", se reporter à le 3.50.

Les recommandations relatives aux essais de conformité durant la fabrication sont données à l'Annexe N.

Les exigences et les tolérances admises dans le présent document concernent l'essai d'un échantillon d'essai de type soumis à cette vérification. La conformité de l'échantillon d'essai de type ne préjuge pas de celle de la production totale d'un fabricant. La conformité de production est de la responsabilité du fabricant, et peut comporter des essais systématiques et d'assurance qualité, en complément des essais de type.

4.2.2 Sauf spécification contraire dans le présent document ou dans la partie correspondante de la série IEC 60598-2, les luminaires doivent être évalués dans leur état livraison et installés comme en usage normal, à une température ambiante comprise entre 10 °C et 30 °C, en tenant compte des instructions d'installation du fabricant. Les lampes et les sources de lumière remplaçables ne sont pas montées, sauf si cela est essentiel pour l'essai. Les sources de lumière non remplaçables et les sources de lumière non remplaçables par l'utilisateur sont des composants essentiels pour démontrer la conformité au présent document.

Les exigences du présent document sont fondées sur la catégorie de surtension II, qui est considérée comme étant appropriée pour l'application normale des luminaires couverts par le domaine d'application de la série IEC 60598. L'Annexe Q fournit une recommandation qui permet aux luminaires d'avoir une tenue aux surtensions supérieure pour une catégorie de surtension III.

Les luminaires ne peuvent pas être considérés comme conformes aux exigences du présent document sauf si leur câblage interne est complet.

En général, les essais sont effectués sur un seul échantillon de luminaire ou, si une gamme de luminaires semblables est concernée, sur un seul luminaire de chaque puissance assignée de la gamme ou sur un choix représentatif de la gamme acceptée en accord avec le fabricant (voir Annexe P). Cette sélection doit comprendre le luminaire ainsi que tous ses accessoires de fixation, constituant la combinaison la plus défavorable du point de vue des essais.

Chaque échantillon de luminaire doit satisfaire à tous les essais qui lui sont applicables. Afin de réduire la durée des essais et de permettre la réalisation d'essais qui peuvent être destructifs, le fabricant peut soumettre des luminaires ou des parties de luminaires identiques supplémentaires composés des mêmes matériaux. Dans le cas où l'essai de conformité est spécifié comme étant "par examen", celui-ci doit comporter toutes les manipulations nécessaires.

Dans le cas des luminaires montés sur rail, le fabricant doit fournir avec le luminaire un échantillon du rail, du connecteur et des adaptateurs appropriés au moyen desquels le luminaire doit être connecté.

Les luminaires composés sont soumis aux essais de sécurité après avoir été assemblés de façon à donner les résultats les plus défavorables.

Certaines parties des luminaires (par exemple les raccords, les appareils à contrepoids) peuvent être soumises à l'essai séparément à condition que leur conception soit telle que leurs performances ne dépendent pas des autres parties du luminaire.

Les luminaires destinés à être utilisés avec des cordons d'alimentation sont soumis à l'essai avec le cordon d'alimentation souple connecté au luminaire.

Pour les luminaires destinés à être utilisés avec un abat-jour, mais qui n'en sont pas normalement équipés, le fabricant doit fournir un abat-jour représentatif du type qui peut être utilisé avec le luminaire.

Les luminaires qui contiennent des batteries ou des EDLC et leurs accessoires (par exemple, une télécommande) doivent en outre satisfaire aux exigences données à l'Annexe W.

L'Annexe W ne s'applique pas aux luminaires pour éclairage de secours. Toutes les exigences relatives aux batteries/EDLC pour les luminaires pour éclairage de secours sont indiquées dans l'IEC 60598-2-22.

4.2.3 En ce qui concerne la vérification et les essais, il est admis de mettre à jour des rapports d'essai antérieurs conformément au présent document pour des essais de luminaires selon les exigences du présent document, en soumettant un nouvel échantillon à l'essai en même temps que les rapports d'essais précédents.

Il n'est généralement pas nécessaire de réaliser un essai de type complet, seuls le produit ainsi que les précédents résultats d'essais sont revus pour tous les articles modifiés répertoriés à l'Annexe O.

4.3 Éléments constitutifs des luminaires

4.3.1 Les composants autres que les composants intégrés doivent satisfaire aux exigences des normes IEC correspondantes, si elles existent. Cependant, les éléments et piles doivent être étudiés conformément au 4.3.4.

NOTE 1 Les douilles de lampe, interrupteurs, transformateurs, appareillages de commande, câbles et cordons souples et fiches sont des exemples de composants.

Les composants qui satisfont aux exigences de la norme IEC correspondante, et qui sont marqués avec des caractéristiques assignées individuelles, sont contrôlés, afin d'établir qu'ils remplissent les conditions qui peuvent survenir lors de l'utilisation. Les aspects d'une utilisation qui ne sont pas couverts par leur norme respective doivent exiger qu'ils satisfassent aux spécifications additionnelles correspondantes du présent document.

La conformité est vérifiée par examen et par les essais correspondants.

Les composants intégrés doivent, en tant que parties des luminaires, être conformes, dans toute la mesure du possible, aux normes de l'IEC relatives aux composants.

NOTE 2 Cela n'implique pas que les composants soient soumis à l'essai séparément avant l'acceptation du luminaire.

NOTE 3 Des recommandations relatives au choix des composants dans différents types de luminaires peuvent être obtenues à l'Annexe J.

Le câblage interne d'un luminaire doit être conforme aux exigences du 8.3.

NOTE 4 Cela n'exclut pas l'utilisation de câbles normalisés.

4.3.2 Les composants qui satisfont aux exigences de leur propre norme et utilisés selon l'usage prévu ne doivent être soumis à l'essai que pour les exigences du présent document pour lesquelles il n'y a pas d'exigences dans la norme de composants (couvrant les exigences indiquées en tête du présent document).

Un rapport d'essai valable est considéré comme suffisant pour prouver la conformité.

Pour les blocs de jonction avec contacts automatiques de terre de protection intégrés pour connexion directe au corps du luminaire ou à ses parties, des exigences spéciales s'appliquent selon l'Annexe R.

4.3.3 Les composants pour lesquels il n'existe pas de norme IEC appropriée doivent, en tant que partie du luminaire, satisfaire aux exigences pertinentes du présent document. Les douilles de lampe et les douilles de starter doivent, de plus, être conformes aux exigences de calibrage et d'interchangeabilité de leurs propres normes de composants de l'IEC, là où elles s'appliquent.

4.3.4 Pour les luminaires, les batteries/EDLC doivent être conformes aux normes de l'IEC, comme suit:

- les batteries composées d'éléments lithium-ion ne doivent pas satisfaire à l'IEC 62133-2. Elles sont soumises à l'essai en tant que partie intégrante du luminaire conformément au présent document;
- les éléments lithium-ion doivent satisfaire à l'IEC 62133-2;
- les éléments et batteries de technologies autres que lithium-ion ne sont pas tenus de satisfaire à l'IEC 62133-1 ni à l'IEC 62133-2. Ils sont soumis à l'essai en tant que partie intégrante du luminaire conformément au présent document;
- les EDLC doivent satisfaire aux exigences de l'IEC 62391-1 et de l'IEC 62391-2.

4.4 Informations relatives à la conception des luminaires dans les normes relatives aux sources de lumière et aux appareillages de commande

4.4.1 Conformément aux lignes directrices de l'IEC, les normes de l'IEC sont classées selon leur domaine d'application: la sécurité ou les performances.

4.4.2 Dans les normes de sécurité des sources de lumière et des appareillages de commande, des "informations relatives à la conception des luminaires" sont données pour un fonctionnement sûr des sources de lumière ou des appareillages de commande; ces informations doivent être considérées comme normatives lors de l'essai des luminaires selon le présent document.

4.4.3 Dans les normes de performance des sources de lumière ou des appareillages de commande, des "informations relatives à la conception des luminaires" sont données pour le bon fonctionnement des sources de lumière ou des appareillages de commande; ces informations doivent être considérées comme informatives lors de l'essai des luminaires selon le présent document. Les essais de performances des sources de lumière ou des appareillages de commande ne sont pas exigés dans le cadre de l'acceptation de l'essai de type pour les luminaires.

5 Classification des luminaires

5.1 Généralités

Les luminaires sont classés en fonction du type de protection contre les chocs électriques, du degré de protection contre la pénétration des poussières, des corps solides et de l'humidité, du matériau de leur surface de montage et des conditions d'utilisation.

5.2 Classification en fonction du type de protection contre les chocs électriques

Les luminaires doivent être classés en fonction de leur type de protection contre les chocs électriques en classe I, classe II ou classe III (voir les définitions 3.24, 3.25 et 3.26).

Tout luminaire ne doit appartenir qu'à une seule classification. Par exemple, dans le cas d'un luminaire avec un composant encastré tel qu'un transformateur de très basse tension est intégré avec possibilité de mise à la terre pour des raisons de protection, ce luminaire doit être classé en classe I et aucune partie de ce luminaire en classe III, même si le compartiment de la lampe est séparé par une cloison du compartiment du transformateur.

Les semi-luminaires doivent satisfaire à toutes les exigences correspondantes des luminaires de classe II, sans être marqués du symbole de la classe II.

NOTE 1 À moins qu'il ne conçoive des luminaires pour être utilisés spécifiquement avec des semi-luminaires, il n'est pas de la responsabilité du fabricant de luminaires d'assurer que la conformité à la série IEC 60598 est perpétuée lorsque l'utilisateur a remplacé les types de lampes spécifiés par des semi-luminaires. Il appartient au fabricant de semi-luminaires d'apporter les informations concernant les limites d'utilisation.

NOTE 2 Le symbole de classe II est omis, afin d'éviter que le symbole ne soit appliqué au luminaire complet dans lequel le semi-luminaire est utilisé.

5.3 Classification en fonction du degré de protection contre la pénétration des poussières, des corps solides et de l'humidité

Les luminaires doivent être classés conformément aux "numéros IP" du système de classification exposé dans l'IEC 60529.

Les essais pour déterminer les degrés de protection sont indiqués à l'Article 11.

NOTE Les luminaires classés comme étanches à l'immersion ne conviennent pas nécessairement au fonctionnement sous l'eau. Les luminaires étanches à l'immersion sous pression peuvent être utilisés pour ces applications.

5.4 Classification selon le matériau de la surface de montage pour laquelle le luminaire est conçu

Les luminaires doivent être classés selon qu'ils sont conçus pour être installés directement sur des surfaces normalement inflammables ou qu'ils sont conçus pour être uniquement installés sur des surfaces non combustibles de la façon suivante:

Classification	Symbole
– Luminaires conçus pour installation directe sur des surfaces normalement inflammables	Aucun symbole exigé
– Luminaires non conçus pour installation directe sur des surfaces normalement inflammables (conçus uniquement pour une installation sur des surfaces non combustibles)	Symboles appropriés (voir Figure 9)

NOTE Les surfaces en matériau facilement inflammable ne sont pas adaptées pour le montage direct des luminaires. Les exigences relatives aux luminaires classés comme destinés en premier lieu pour être installés directement sur des surfaces normalement inflammables sont indiquées à l'Article 7 et les essais correspondants à l'Article 14.

5.5 Classification selon les conditions d'emploi

Les luminaires doivent être classés comme suit, selon qu'ils sont prévus pour un usage normal ou pour des conditions sévères d'emploi.

Classification	Symbole
– Luminaires pour usage normal	Pas de symbole
– Luminaires pour conditions sévères d'emploi	Symbole (voir Figure 16)

6 Marquage

6.1 Généralités

Quelles que soient les instructions écrites concernant la sécurité, celles-ci doivent être rédigées dans une langue qui est acceptée dans le pays où l'équipement sera installé.

6.2 Marquage sur les luminaires

Les informations suivantes doivent être distinctement et durablement marquées sur le luminaire (voir Tableau 1). Chaque marquage du Tableau 1 doit être lu avec le paragraphe correspondant comme cela est indiqué dans le tableau.

- a) Le marquage qui doit être observé lors du remplacement des lampes ou d'autres composants remplaçables doit être visible à l'extérieur du luminaire (à l'exception de la surface de montage) ou derrière une vasque qui est enlevée pendant le remplacement de la lampe ou d'un autre composant, et lorsque la lampe est enlevée.
- b) Le marquage qui doit être observé pendant l'installation du luminaire doit être visible à l'extérieur de celui-ci, ou derrière une vasque ou une partie qui est enlevée lors de l'installation.
- c) Le marquage qui doit être observé après l'installation doit être visible lorsque le luminaire est assemblé et installé, avec les lampes en position, comme en usage normal.

Le marquage peut figurer sur les appareillages de commande, dans la mesure où les conditions a) ou b) ci-dessus sont remplies, lorsqu'elles s'appliquent. Pour plus d'informations, voir le Tableau 1.

IECNORM.COM : Click to view the full PDF of IEC 60598-1:2024

Tableau 1 – Marquage

Marquages selon 6.2, a)	Marquages selon 6.2, b)	Marquages selon 6.2, c)
6.3.8 a) et c) ^a Puissance assignée 6.3.10 Lampes spéciales 6.3.11 Faisceau froid 6.3.15 Calotte argentée 6.3.16 Écran de protection 6.3.18 Avertisseur amorceur 6.3.19 Lampe autoprotégée 6.3.21 Fusible(s) interne(s) remplaçable(s) 6.3.22 Ne pas fixer la source de lumière ^e 6.3.23 Symbole pour le risque de chocs électriques 6.3.26 Caractéristiques assignées de la sortie électrique ^h	6.3.1 à 6.3.2 ^b 6.3.3 Température ambiante 6.3.4 à 6.3.5 6.3.6 Indice IP 6.3.7 Référence du type 6.3.8 b) Puissance d'entrée assignée 6.3.9 Symboles Symbole correspondant pour les luminaires qui ne sont pas conçus pour être installés directement sur une surface normalement inflammable 6.3.12 Bornes 6.3.17 ^c Luminaires interconnectés 6.3.24 Tension constante d'entrée assignée ^f 6.3.25 Courant constant d'entrée assigné et valeur de I_{out} ^g 6.3.26 Caractéristiques assignées de la sortie électrique ^h	6.3.13 Objets éclairés ^d 6.3.14 Conditions sévères d'emploi 6.3.20 Moyens de réglage 6.3.22 Ne pas fixer la source de lumière ^e 6.3.27 Courant assigné du socle de prise de courant réseau
<p>^a 6.3.8 c) Puissance assignée. Pour les luminaires équipés de lampes à décharge, avec appareillage distant, le marquage peut être remplacé par une instruction: "Pour le type de lampe, voir l'appareillage de commande".</p> <p>^b 6.3.2 Tension assignée. Pour les luminaires équipés de lampes à décharge, si le ballast n'est pas incorporé au luminaire, celui-ci doit être marqué avec la tension de service, au lieu de la tension réseau.</p> <p>^c 6.3.17 Luminaires interconnectés. Dans le cas des luminaires fixes, cette information peut être également donnée dans les instructions d'installation.</p> <p>^d 6.3.13 Objets éclairés. Le luminaire doit seulement comporter le symbole. L'explication du symbole doit être fournie dans les instructions accompagnant le luminaire, si elle ne figure pas déjà sur le luminaire.</p> <p>^e 6.3.22 Les différentes conditions de ce marquage pour les luminaires fixes, portatifs et les baladeuses sont données en 6.3.22.</p> <p>^f 6.3.24 Pour le fonctionnement en tension constante du luminaire.</p> <p>^g 6.3.25 Pour le fonctionnement en courant constant du luminaire.</p> <p>^h 6.3.26 Les différentes conditions de ce marquage pour les luminaires avec appareillage de commande indépendant intégré ou externe sont données en 6.3.26.</p>		

Le symbole de mise à la terre mentionné en 6.3.12 peut être marqué sur l'appareillage de commande au lieu de l'être sur le luminaire, si l'appareillage de commande est du type non remplaçable. La hauteur des symboles graphiques ne doit pas être inférieure à 5 mm, à l'exception de celle des symboles pour classification de classe II et classe III qui peut être réduite jusqu'à un minimum de 3 mm lorsque l'espace disponible pour le marquage est réduit. La hauteur des lettres et chiffres figurant soit séparément, soit avec, soit comme partie de symboles ne doit pas être inférieure à 2 mm.

Dans le cas des luminaires commercialisés comme une combinaison de différentes parties (par exemple, enveloppe pour la source de lumière et enveloppe pour l'appareillage de commande) pour lesquels les références du type ou les puissances assignées sont différentes pour les diverses combinaisons, la partie principale et les parties annexes peuvent être marquées de la référence du type ou de la puissance assignée, selon le cas, à condition que le type puisse être identifié et que la puissance assignée de l'unité complète puisse être déterminée d'après un catalogue ou une documentation analogue.

Pour les luminaires à systèmes de contacts électromécaniques, la plaque de base doit être marquée du courant assigné de la connexion électrique si le système peut être utilisé avec une variété de types de luminaires différents.

6.3 Informations à marquer sur les luminaires

6.3.1 Marque d'origine (elle peut prendre la forme d'une marque commerciale, de la marque d'identification du fabricant ou du nom du fournisseur responsable).

6.3.2 Tension(s) assignée(s) en volts et type d'alimentation

Pour le type d'alimentation, il doit s'agir de l'un des marquages suivants:

- avec le symbole relatif au type d'alimentation (voir Figure 4, Figure 5 ou Figure 6);
- par l'abréviation CC (courant continu) ou CA (courant alternatif);
- par le marquage de la fréquence assignée ou des fréquences assignées; ou
- comme cela est décrit dans le Tableau 3 pour les câbles et les bornes utilisés pour le raccordement aux alimentations à très basse tension en courant continu.

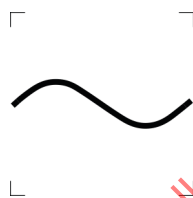

(IEC 60417-5032:2002-10)

Figure 4 – Alimentation en courant alternatif

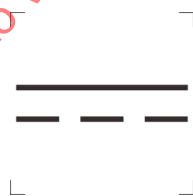

(IEC 60417-5031:2002-10)

Figure 5 – Alimentation en courant continu

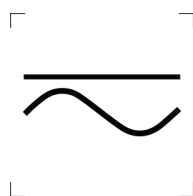

(IEC 60417-5033:2002-10)

Figure 6 – Alimentation en courant continu et alternatif

Le marquage relatif au type d'alimentation peut être omis lorsque l'alimentation peut être à la fois en courant alternatif et en courant continu, mais s'il est apposé, la Figure 6 doit être utilisée.

Les luminaires portatifs de la classe III doivent porter le marquage de la tension assignée à l'extérieur du luminaire.

Les luminaires équipés de transformateurs ou de convertisseurs intégrés doivent être marqués de la tension ou du courant nominal de la source de lumière, ou des deux, afin d'assurer un remplacement correct. Ce marquage doit être positionné conformément au 6.3.8.

Si un marquage est fourni conformément au 6.3.24 ou au 6.3.25, un marquage supplémentaire de la tension assignée n'est pas exigé.

Les luminaires alimentés par le biais d'un PSE externe doivent porter un marquage indiquant la tension assignée qui se situe dans la plage des valeurs de tension indiquées dans le Tableau U.2, pour les connecteurs ou câbles de communication choisis.

6.3.3 Température ambiante assignée maximale t_a , si elle diffère de 25 °C, comme suit:

$$t_{a...} \text{ °C}$$

6.3.4 Symbole des luminaires de classe II, s'il y a lieu (voir Figure 7).

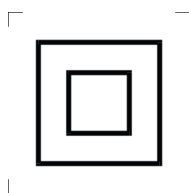

(IEC 60417-5172:2003-02)

Figure 7 – Classe II

Pour les luminaires portatifs équipés d'un cordon d'alimentation, le symbole de construction de la classe II, s'il s'applique, doit être porté à l'extérieur du luminaire.

Le symbole de la classe II ne doit pas être appliqué aux semi-luminaires.

6.3.5 Symbole des luminaires de classe III, s'il y a lieu (voir Figure 8). Ce symbole n'est pas exigé pour les luminaires de classe III qui fonctionnent exclusivement sur batterie/EDLC et qui ne sont pas conçus pour être connectés à une alimentation par chargeur.



(IEC 60417-5180:2003-02)

Figure 8 – Classe III

6.3.6 Marquage (s'il y a lieu) des indices IP du degré de protection contre la pénétration des poussières, des corps solides et de l'humidité (voir Tableau 2 et Annexe H). Si X est utilisé dans un indice IP du Tableau 2, cela signifie qu'un chiffre manque dans l'exemple, mais les deux chiffres appropriés doivent être marqués sur le luminaire.

Tableau 2 – Indices IP du degré de protection contre la pénétration des poussières, des corps solides et de l'humidité

Ordinaire	IP20
Protégé contre les chutes d'eau verticales	IPX1
Protégé contre les chutes d'eau verticales (15°)	IPX2
Protégé contre la pluie	IPX3
Protégé contre les projections d'eau	IPX4
Protégé contre les jets d'eau	IPX5
Étanche aux jets d'eau puissants	IPX6
Étanche à l'immersion	IPX7
Étanche à l'immersion sous pression	IPX8 m (suivi d'une indication de la profondeur maximale d'immersion en mètres)
Protégé contre les jets d'eau à haute pression et haute température	IPX9 (80 °C)
Protégé contre les jets d'eau froide à haute pression	IPX9 (15 °C)
Protégé contre les corps solides de plus de 2,5 mm	IP3X
Protégé contre les corps solides de plus de 1 mm	IP4X
Protégé contre les poussières	IP5X
Étanche aux poussières	IP6X

Dans les cas où des degrés IP différents s'appliquent à des parties distinctes du luminaire, le degré le plus faible doit être marqué sur l'étiquette type du luminaire, même s'il est IP20, tandis que le degré le plus élevé doit être marqué séparément sur la partie concernée. Lorsque des abat-jour ou des appareils similaires de relèvement de degré IP sont utilisés (portant par exemple un luminaire d'IP20 à un degré IP plus élevé lors de son installation), le marquage de l'IP20 doit être rendu invisible par l'appareil en question sans que le marquage soit détruit et l'appareil doit comporter de manière visible le nouveau degré IP. La feuille d'instruction fournie avec le luminaire doit comporter les détails des numéros IP s'appliquant aux différentes parties du luminaire. L'utilisation de différents numéros IP sur différentes parties du luminaire ou appareils augmentant, par exemple, le degré IP à un niveau plus élevé est seulement applicable aux luminaires fixes.

Le marquage IP20 sur les luminaires ordinaires n'est pas exigé.

6.3.7 Numéro de modèle du fabricant ou référence du type.

6.3.8 Les luminaires doivent porter un marquage qui indique la puissance assignée maximale de la source de lumière ou la puissance d'entrée maximale selon a), b) ou c).

a) Les luminaires pour lampes à filament de tungstène doivent porter un marquage qui indique la puissance assignée maximale du luminaire et le nombre de lampes.

Le marquage de la puissance assignée maximale pour les luminaires pour lampes à filament de tungstène ayant plus d'une douille peut prendre la forme:

" $n \times \text{MAX} \dots \text{W}$ ", n étant le nombre de douilles.

b) Les luminaires conçus pour des sources de lumière non remplaçables ou non remplaçables par l'utilisateur doivent porter un marquage qui indique la puissance d'entrée assignée du luminaire.

Le marquage de la puissance d'entrée assignée n'est pas exigé pour les luminaires de classe III qui fonctionnent exclusivement sur batterie/EDLC et qui ne sont pas conçus pour être connectés à une alimentation par chargeur.

NOTE L'objectif du marquage de la puissance d'entrée assignée est de fournir un guide aux installateurs. Le présent document ne définit pas d'essai pour la puissance d'entrée assignée.

- c) Pour tous les autres luminaires, la puissance assignée de la lampe ou désignation comme cela est indiqué sur la feuille de caractéristiques du type ou des types de lampes pour lesquelles le luminaire est conçu. Lorsque la puissance de la lampe seule est insuffisante, le nombre de lampes et leur type doivent aussi être donnés.

6.3.9 Lorsque cela est applicable, symbole (voir Figure 9) pour les luminaires non conçus pour installation directe sur des surfaces normalement inflammables. Le symbole doit être expliqué sur le luminaire ou dans les instructions du fabricant accompagnant le luminaire. Voir Tableau L.1. La taille minimale du symbole doit être de 25 mm pour chaque côté.

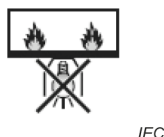

Figure 9 – Luminaires non conçus pour montage direct sur des surfaces normalement inflammables

6.3.10 Informations qui concernent des lampes spéciales, s'il y a lieu.

Cela s'applique en particulier aux symboles (voir Figure 10 et Figure 11) pour luminaires destinés à être utilisés avec des lampes sodium HP (haute pression) qui ont un appareil d'amorçage interne ou qui nécessitent un amorçeur externe lorsque l'IEC 60662 exige que la lampe soit marquée du même symbole.



(SOURCE: IEC 60662)

Figure 10 – Lampes sodium à haute pression qui nécessitent un amorçeur externe (à la lampe)



(SOURCE: IEC 60662)

Figure 11 – Lampes sodium à haute pression qui ont un appareil d'amorçage interne

6.3.11 Symbole (voir Figure 12), s'il y a lieu, pour les luminaires pour lampes de forme similaire aux lampes "à faisceau froid", mais où l'emploi d'une lampe "à faisceau froid" réfléchissante dichroïque peut compromettre la sécurité.

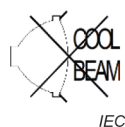
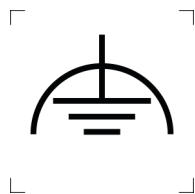

Figure 12 – Avertissement contre l'usage des lampes à faisceau froid

6.3.12 Excepté pour les fixations de type Z, les bornes doivent être marquées pour identifier la phase, le neutre et la terre lorsque le luminaire est connecté au réseau pour assurer la sécurité et le bon fonctionnement.

Les symboles indiquant les bornes du réseau, lorsqu'ils sont utilisés, doivent être issus de l'IEC 60417.

La borne de terre ne doit être marquée qu'avec le symbole correspondant de l'IEC 60417 (voir Figure 13 et Figure 14).



(IEC 60417-5018:2011-07)

Figure 13 – Mise à la terre fonctionnelle

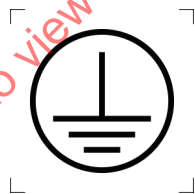

(IEC 60417-5019:2006-08)

Figure 14 – Mise à la terre de protection

Lorsque des bornes sont fournies dans un luminaire de classe II pour assurer la continuité électrique ou être l'extrémité d'un conducteur de terre de protection, ces bornes doivent être marquées avec la lettre E.

NOTE 1 Des exemples de telles bornes sont celles utilisées comme câbles de repiquage ou lignes traversantes.

Les câbles de raccordement (sorties) et les bornes utilisés pour la connexion à l'alimentation de très basse tension en courant continu doivent indiquer la connexion prévue choisie parmi les combinaisons mentionnées ci-dessous (voir Tableau 3):

Tableau 3 – Identification des câbles de raccordement et des bornes de très basse tension en courant continu

Positive	Négative
"+"	"-"
De couleur rouge ^a	De couleur noire ^a
^a L'utilisation d'étiquettes ou d'une gaine fixée(s) aux câbles, pour donner une des identifications ci-dessus, est autorisée.	

NOTE 2 Les bornes peuvent se trouver sous forme de câbles de raccordement (sorties), blocs de jonction ou de raccordement et bornes d'une autre construction.

Les luminaires avec cordon d'alimentation qui ne sont pas équipés d'une fiche doivent inclure, avec les instructions du fabricant, les informations nécessaires pour assurer une connexion sûre, par exemple des différences par rapport à la codification nationale des couleurs normalisées des âmes lorsque cela ne crée pas de situation dangereuse pendant l'installation, l'utilisation ou la maintenance.

NOTE 3 Dans certains pays, les luminaires avec cordon d'alimentation destinés à être connectés au réseau par l'intermédiaire d'un socle de prise de courant et non équipés de fiches ne sont pas admis.

6.3.13 Symbole (voir Figure 15) qui indique, s'il y a lieu, la distance minimale des objets éclairés, dans le cas de luminaires qui sont susceptibles de surchauffer les objets éclairés, en raison par exemple du type de lampe utilisé, de la forme du réflecteur, du réglage des moyens de montage ou de la position de montage, comme cela est indiqué dans les instructions d'installation.



Figure 15 – Distance minimale des objets éclairés (mètres)

La distance minimale marquée doit être déterminée au moyen de l'essai de température décrit au 14.4.2, point j).

La distance est mesurée sur l'axe optique du luminaire depuis la partie du luminaire ou de la lampe qui est la plus proche à l'objet éclairé.

Le symbole indiquant la distance minimale et l'explication correspondante doivent aussi être portés soit sur le luminaire, soit dans les instructions fournies avec le luminaire.

6.3.14 Symbole (voir Figure 16), s'il y a lieu, pour les luminaires pour conditions sévères d'emploi.

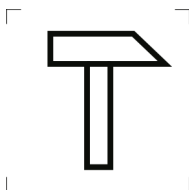

(IEC 60417-6034:2010-04)

Figure 16 – Conditions sévères d'emploi

6.3.15 Symbole (voir Figure 17), s'il y a lieu, pour les luminaires conçus pour être équipés de lampes à calotte argentée.

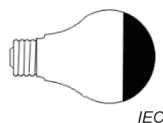

Figure 17 – Lampe à calotte argentée

NOTE Les calottes séparées pouvant être fixées sur les lampes d'éclairage général, sans référence à l'essai du luminaire, ne relèvent pas du domaine d'application du présent document.

6.3.16 Les luminaires avec un écran de protection doivent être marqués avec:

- "Remplacer tout écran de protection fissuré", ou
- le symbole approprié (voir Figure 18).

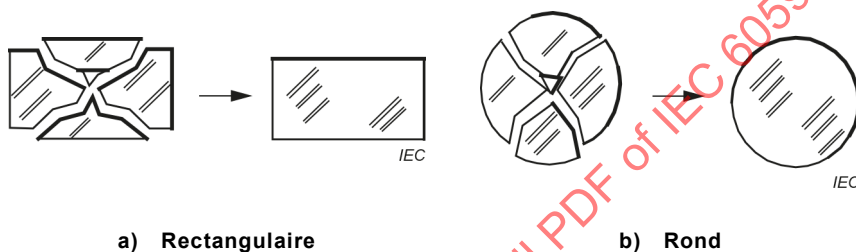
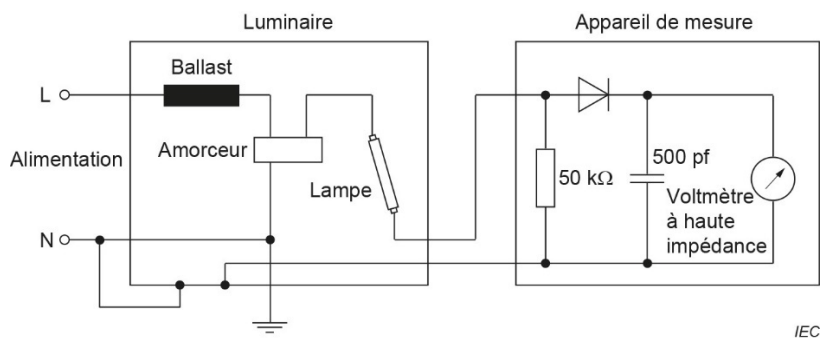

Figure 18 – Remplacer tout écran de protection fissuré

6.3.17 Le nombre maximal de luminaires qui peuvent être interconnectés, ou le courant total maximal qui peut être obtenu au moyen de coupleurs fournis pour le repiquage sur le réseau d'alimentation. Dans le cas des luminaires fixes, cette information peut être également donnée dans les instructions d'installation.

6.3.18 Un symbole d'avertissement ou une notice, pour les luminaires avec amorceurs prévus pour utiliser des lampes à décharge haute pression à deux extrémités, ainsi que les luminaires pour lampes tubulaires Fa8 à deux culots, si la tension mesurée selon la Figure 19 dépasse 34 V en crête:

- a) un symbole d'avertissement, conforme à celui de l'IEC 60417-5036:2002-10, visible pendant le remplacement de la lampe. Le symbole doit être expliqué sur le luminaire ou dans les instructions du fabricant accompagnant le luminaire, ou
- b) une notice d'avertissement près du porte-amorceur remplaçable, ou de l'élément de commutation remplaçable, s'il existe: "Attention, enlever l'appareil remplaçable, avant de changer la lampe. Après remplacement de la lampe, remettre en place l'appareil enlevé".



Après le premier mesurage, la polarité de la diode doit être inversée et l'essai répété.

Figure 19 – Circuit d'essai pour le contrôle de la sécurité lors de l'insertion des lampes

6.3.19 Symbole (voir Figure 20) pour luminaires qui sont conçus pour utilisation uniquement avec des lampes tungstène-halogène autoprotégées ou des lampes aux halogénures métalliques autoprotégées.

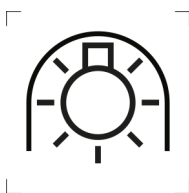

(IEC 60417-6030:2009-11)

Figure 20 – Lampe autoprotégée

6.3.20 Si cela est nécessaire, les dispositifs de réglage, lorsqu'ils ne sont pas aisément reconnaissables, doivent être identifiés.

NOTE Un marquage approprié inclut les symboles (par exemple flèches) pour indiquer la direction des mouvements, un texte descriptif, ou des couleurs.

6.3.21 Symbole (voir Figure 21), s'il y a lieu, pour les luminaires avec fusibles internes remplaçables. Un tel luminaire doit, de plus, comporter des informations concernant le courant assigné (en A ou mA) du fusible. Lorsque la caractéristique temps-courant du fusible est importante pour la sécurité, la valeur assignée et le type de tout fusible doivent être indiqués sur le porte-fusible ou à proximité du fusible conformément aux indications de la norme du fusible correspondant.

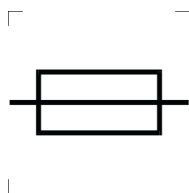

(IEC 60417-5016:2002-10)

Figure 21 – Luminaires avec fusible interne

6.3.22 Pour le danger lié à la lumière bleue, les luminaires évalués selon l'IEC 62471-7:2023 doivent satisfaire au 6.3.22 a) et les luminaires évalués selon l'IEC TR 62778:2014² doivent satisfaire au 6.3.22 b).

NOTE 1 Il est prévu que la prochaine édition du présent document supprime le 6.3.22 b), car l'IEC 62471-7 remplace complètement l'IEC TR 62778. Dans l'intervalle, les 6.3.22 a) et 6.3.22 b) peuvent être utilisés en fonction de la manière dont le luminaire a été évalué conformément au 7.24.3.

a) Informations sur le danger rétinien lié à la lumière bleue pour les luminaires évalués conformément à l'IEC 62471-7:2023

Pour les luminaires fixes dont la distance d'évaluation x est augmentée conformément au 7.24.3.2, les instructions du fabricant fournies avec le luminaire doivent inclure le texte suivant:

"Le luminaire doit être positionné de telle manière que le regard prolongé du luminaire à une distance inférieure à x m ne soit pas envisageable".

NOTE 2 Un regard prolongé n'est pas attendu en raison de la réaction naturelle d'aversion aux sources de lumière brillante. Une exposition momentanée n'est pas considérée comme un regard prolongé.

b) Informations sur le danger rétinien lié à la lumière bleue pour les luminaires évalués conformément à l'IEC TR 62778:2014

Symbole d'avertissement "Ne pas fixer la source de lumière en fonctionnement" (voir Figure 22) pour les luminaires portatifs et les baladeuses qui ont été classés comme possédant un seuil de l'éclairement lumineux E_{thr} conformément à l'IEC TR 62778. Ce marquage doit être visible comme cela est décrit par l'exigence c) du 6.2 et par le Tableau 1. De plus il convient que le symbole soit positionné de telle manière qu'il puisse être lu sans regarder la source de lumière en fonctionnement. Cette exigence est uniquement applicable lorsque E_{thr} est atteint à une distance supérieure à 200 mm du luminaire.



Figure 22 – Ne pas fixer la source de lumière en cours de fonctionnement

Pour les luminaires fixes qui ont été classés comme possédant un seuil de l'éclairement lumineux E_{thr} conformément à l'IEC TR 62778, les instructions du fabricant fournies avec le luminaire doivent inclure le texte suivant, où x m désigne la distance à laquelle le seuil de l'éclairement lumineux E_{thr} survient. Cette exigence est uniquement applicable lorsque E_{thr} est atteint à une distance supérieure à 200 mm du luminaire.

"Il convient que le luminaire soit positionné de telle manière que le regard prolongé du luminaire à une distance inférieure à x m ne soit pas envisageable".

NOTE 3 Conformément à l'IEC TR 62778, x m désigne la distance d_{thr} entre la source de lumière et les yeux de l'observateur et est calculée à partir du mesurage de la répartition de l'éclairage du luminaire.

NOTE 4 Un regard prolongé n'est pas attendu en raison de la réaction naturelle d'aversion aux sources de lumière brillante. Une exposition momentanée n'est pas considérée comme un regard prolongé.

NOTE 5 Conformément au 6.1.3 de l'IEC 62471:2006, "la base de raisonnement, pour une classification dans le groupe de risque 2 (risque modéré), est que la lampe ne présente pas un danger lié à la réponse d'aversion pour les sources de lumière très brillante (...)".

NOTE 6 Les exigences de marquage ci-dessus ont été établies selon l'IEC TR 62471-2:2009³.

² Supprimée.

³ Supprimée.

De plus, les luminaires qui incorporent des sources de lumière remplaçables ou non remplaçables par l'utilisateur qui ont été classés comme possédant un seuil de l'éclairement lumineux E_{thr} conformément à l'IEC TR 62778 et directement visibles lors de la maintenance du luminaire doivent être marqués avec le symbole d'avertissement "Ne pas fixer la source de lumière en fonctionnement" (voir Figure 22). Ce marquage doit être visible comme cela est décrit par les exigences a) du 6.2 et par le Tableau 1.

6.3.23 Lorsque cela est exigé pour la protection contre les chocs électriques, les vasques fixées sur les sources de lumière non remplaçables par l'utilisateur et sur les composants non remplaçables par l'utilisateur final doivent être marquées avec le symbole "Danger, risque de chocs électriques" indiqué sur la Figure 23. La hauteur minimale de ce symbole doit être de 15 mm.

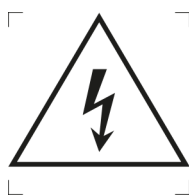

(IEC 60417-6042:2010-11)

Figure 23 – Danger, risque de chocs électriques

6.3.24 Tension constante d'entrée assignée lorsqu'un luminaire est mis en fonctionnement à partir d'un appareillage à tension constante, non fourni avec le luminaire.

6.3.25 Courant constant d'entrée assigné lorsque le luminaire est mis en fonctionnement à partir d'un appareillage à courant constant, non fourni avec le luminaire. Les luminaires alimentés par courant constant doivent également porter un marquage qui indique la valeur de U_{out} maximale admise de l'appareillage.

6.3.26 Pour les luminaires qui utilisent une source de lumière à LED et qui contiennent un appareillage de commande intégré, les caractéristiques assignées maximales de la sortie électrique de chaque appareillage de commande (par exemple courant pour un appareillage de commande à courant constant), pour lesquelles le luminaire a été conçu, doivent être marquées selon les exigences de la première colonne du Tableau 1 appartenant au point a). Pour les luminaires qui utilisent un appareillage de commande externe indépendant fourni avec le luminaire, ce marquage doit être visible conformément à la deuxième colonne du Tableau 1 appartenant au point b). Cette exigence ne s'applique pas:

- aux luminaires qui utilisent une source de lumière à LED et dont l'appareillage de commande fourni avec le luminaire a une valeur de sortie fixe (valeur unique), car ces appareillages de commande sont déjà marqués avec la valeur de sortie;
- aux appareillages de commande fournis avec le luminaire pour lesquels il n'existe aucune possibilité de modification du réglage par l'utilisateur.

NOTE En cas de défaut de l'appareillage de commande, un remplacement correct est attendu avec la livraison par le fabricant du luminaire sur demande.

Pour les luminaires comportant une fonction de flux lumineux constant, ce marquage doit indiquer les conditions maximales de fonctionnement pour lesquelles le luminaire a été conçu.

6.3.27 Le courant assigné doit être marqué près du socle de prise de courant pour tout socle de prise de courant réseau incorporé dans le luminaire, s'il est inférieur à la valeur assignée du socle de prise de courant.

6.4 Renseignements complémentaires

6.4.1 En plus des marquages spécifiés en 6.3, tous les détails nécessaires pour assurer une installation, un usage et une maintenance corrects doivent être portés sur le luminaire, le semi-luminaire ou sur les appareillages de commande intégrés ou dans les instructions que le fabricant fournit avec le luminaire, par exemple.

NOTE La liste donnée du 6.4.2 au 6.4.24 n'est pas exhaustive.

6.4.2 Pour les luminaires combinés, la température ambiante admissible, la classe de protection ou la protection contre la pénétration des poussières, des corps solides et de l'humidité d'une partie annexe si elle n'est pas au moins égale à celle du luminaire de base.

6.4.3 Fréquence assignée ou fréquences assignées en hertz.

6.4.4 Températures de fonctionnement:

- température de fonctionnement maximale assignée (d'un enroulement) t_w en degrés Celsius;
- température de fonctionnement maximale assignée (d'un condensateur) t_c en degrés Celsius;
- température maximale à laquelle est soumise l'isolation des câbles d'alimentation et des câbles d'interconnexion à l'intérieur du luminaire dans les conditions les plus défavorables en fonctionnement normal, si cette température dépasse 90 °C (voir note de bas de page c) du Tableau 22 relative au câblage de l'installation fixe, sans gaine). Le symbole indiquant cette condition est représenté à la Figure 24;

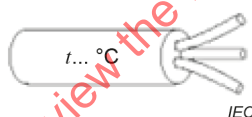

Le nombre d'âmes du câble est facultatif.

Figure 24 – Emploi de câble d'alimentations, d'interconnexions ou de câblages externes résistants à la chaleur

d) les exigences d'espacement qui doivent être observées pendant l'installation.

6.4.5 Un schéma de câblage, sauf si le luminaire est adapté au branchement direct sur le réseau d'alimentation.

6.4.6 Les conditions spéciales auxquelles le luminaire, y compris l'appareillage de commande, est adapté, par exemple si le luminaire est prévu ou non pour le repiquage.

6.4.7 La notice d'avertissement suivante doit être fournie avec les luminaires équipés avec des lampes aux halogénures métalliques qui nécessitent un écran de protection:

"Le luminaire ne doit être utilisé que complet, avec son écran de protection".

6.4.8 Le fabricant de semi-luminaires doit fournir les informations sur les limitations d'utilisation de tels appareils, particulièrement lorsqu'une surchauffe peut être occasionnée par la position ou la répartition thermique de la source de lumière de remplacement lorsque celle-ci est différente de celle qu'elle remplace.

6.4.9 Le fabricant doit être prêt à fournir des informations sur le facteur de puissance et le courant d'alimentation.

Pour la réalisation des connexions correctes des charges résistives et inductives, le courant assigné de la charge inductive doit être indiqué entre parenthèses; cette indication doit suivre immédiatement celle du courant assigné de la charge résistive. Le marquage peut donc être le suivant:

$$3(1)A \ 250 \text{ V} \text{ ou } 3(1)/250 \text{ ou } \frac{3(1)}{250}$$

Les valeurs de courant assigné ne s'appliquent pas aux circuits en général, mais seulement aux valeurs assignées du luminaire dans son ensemble.

6.4.10 Pour les luminaires avec appareillage de commande à distance, la gamme de lampes pour lesquelles le luminaire est conçu.

6.4.11 Pour les luminaires à pince, un avertissement lorsque le luminaire n'est pas adapté au montage sur matériel tubulaire.

6.4.12 Le fabricant doit fournir les spécifications de tous les écrans de protection.

6.4.13 Les informations au sujet des luminaires pour conditions sévères d'emploi qui concernent:

- la connexion à des socles de prise de courant IPX4;
- le montage correct en prenant en compte l'installation provisoire;
- la fixation correcte à un support et, si le support n'est pas fourni avec le luminaire, la hauteur maximale du support possible ainsi que la stabilité exigée par l'indication du nombre et de la longueur minimale des pieds.

6.4.14 Pour les luminaires avec des fixations de type X, Y ou Z, les instructions de montage doivent contenir les informations suivantes.

- Pour les fixations de type X ayant un cordon spécialement conçu:
si le câble ou le cordon extérieur souple de ce luminaire est endommagé, il doit être remplacé par un cordon du même type et de même préparation.
- Pour les fixations de type Y:
si le câble ou le cordon extérieur souple de ce luminaire est endommagé, il doit être remplacé par le fabricant, son agent de maintenance ou une personne qualifiée.
- Pour les fixations de type Z:
le câble ou le cordon extérieur souple de ce luminaire ne peut pas être remplacé; si le câble est endommagé, le luminaire entier doit être remplacé.

6.4.15 Les luminaires autres qu'ordinaires, mais qui conviennent uniquement à une utilisation à l'intérieur (par exemple, s'ils sont équipés d'un cordon d'alimentation en PVC), doivent être accompagnés d'une information en ce qui concerne l'utilisation prévue, c'est-à-dire: "Pour utilisation intérieure uniquement".

6.4.16 Pour les luminaires de classe I qui ont un courant d'alimentation > 20 A, qui génèrent un courant dans le conducteur de protection supérieur à 10 mA et qui sont destinés à être connectés de façon permanente, les éléments suivants doivent être clairement indiqués dans les instructions du fabricant:

- la valeur du courant dans le conducteur de protection, et
- une indication que la connexion à la terre doit être conforme aux règles de câblage qui peuvent exiger des conducteurs de protection renforcés.

NOTE 1 Les exigences relatives aux conducteurs de protection renforcés dans l'installation sont fournies dans l'IEC 60364-5-54:2011, 543.7.

NOTE 2 L'Australie et la Nouvelle-Zélande n'admettent aucun courant dans le conducteur de protection supérieur à 10 mA.

6.4.17 Les appliques murales et les luminaires réglables et ajustables qui ne sont pas conçus pour être montés dans le volume d'accessibilité doivent être fournis avec une information qui précise comment les installer correctement, c'est-à-dire: "Peut seulement être installé en dehors du volume d'accessibilité au toucher".

6.4.18 Pour les luminaires équipés de sources de lumière non remplaçables et non remplaçables par l'utilisateur, les instructions du fabricant doivent comporter les informations suivantes:

- pour les sources de lumière non remplaçables:

"La source de lumière de ce luminaire n'est pas remplaçable; lorsque la source de lumière atteint sa fin de vie, le luminaire entier doit être remplacé".

À la place du texte, le pictogramme de la Figure 25 peut être utilisé pour le marquage sur le produit ou sur l'emballage et doit être expliqué dans les instructions du fabricant fournies avec le luminaire ou par un lien dans les instructions vers l'emplacement de ces informations sur le site web des fabricants;

NOTE 1 L'utilisation d'un code QR ou d'un lien similaire peut convenir à cette exigence.



NOTE Ce pictogramme comprend les symboles suivants: ISO 7000-2795:2006-08 (modifié) et IEC 60417-5012:2002-10.

Figure 25 – Pictogramme pour une source de lumière non remplaçable

- pour les sources de lumière non remplaçables par l'utilisateur:

"La source de lumière contenue dans ce luminaire ne doit être remplacée que par le fabricant, son agent de maintenance ou une personne qualifiée."

À la place du texte, le pictogramme de la Figure 26 peut être utilisé pour le marquage sur le produit ou sur l'emballage et doit être expliqué dans les instructions du fabricant fournies avec le luminaire ou par un lien dans les instructions vers l'emplacement de ces informations sur le site web des fabricants;

NOTE 2 L'utilisation d'un code QR ou d'un lien similaire peut convenir à cette exigence.

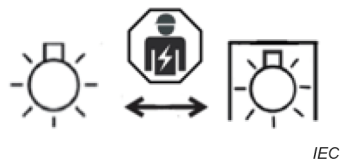

NOTE Ce pictogramme comprend les symboles suivants: IEC 60417-6182:2013-09 et IEC 60417-5012:2002-10.

Figure 26 – Pictogramme pour une source de lumière non remplaçable par l'utilisateur

- pour les sources de lumière remplaçables, la remplaçabilité de la source de lumière par l'utilisateur peut être indiquée à l'aide du pictogramme de la Figure 27.

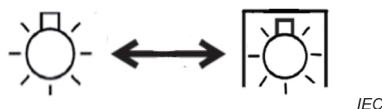

NOTE Ce pictogramme comprend le symbole suivant: IEC 60417-5012:2002-10.

Figure 27 – Pictogramme pour une source de lumière remplaçable

NOTE 3 L'utilisation des pictogrammes pour les sources de lumière remplaçables est facultative. Aucune exigence obligatoire n'est donnée dans le présent document pour la fourniture de ces informations particulières.

6.4.19 Pour les luminaires équipés de bornes de contrôle pour l'échange d'informations de l'appareillage de commande ou le réglage des fonctions de l'appareillage de commande, la classification d'isolation qui a été maintenue entre le réseau d'alimentation et les conducteurs de commande doit être fournie (par exemple, isolation principale, isolation renforcée).

NOTE La maintenance de la cloison d'isolation indiquée pour le luminaire peut également dépendre d'autres composants ou produits externes connectés au même bus de commande.

6.4.20 Les luminaires livrés sans appareillage doivent être fournis avec les informations nécessaires pour le choix du composant approprié (en particulier la distance maximale de câblage et la distance entre l'appareillage et le luminaire), ainsi que la valeur maximale admise U_{out} de l'appareillage et la valeur maximale U_p ou la tension de crête transformée équivalente U_p , lorsque des tensions d'impulsion sont utilisées. De plus, la classification d'isolation de l'appareillage externe qui a été maintenue entre le réseau d'alimentation et la sortie secondaire doit être fournie si au moins une isolation principale est nécessaire.

- Pour les luminaires qui n'exigent pas d'isolation entre le réseau d'alimentation et la sortie de l'appareillage externe, aucune information supplémentaire n'est exigée.
- Pour les luminaires qui exigent une isolation principale entre les circuits primaire et secondaire de l'appareillage, les informations suivantes sont exigées:
"L'appareillage externe doit assurer au moins l'isolation principale entre le réseau d'alimentation et la sortie".
- Pour les luminaires qui ne sont pas classés en classe III, mais qui exigent une double isolation ou une isolation renforcée entre les circuits primaire et secondaire de l'appareillage, les informations suivantes sont exigées:
"L'appareillage externe doit assurer au moins la double isolation ou l'isolation renforcée entre le réseau d'alimentation et la sortie".
- Pour les luminaires classés en classe III, une indication que l'appareillage de commande doit être TBTS/TBTP est exigée, excepté lorsque des parties exposées ont une tension supérieure à 12 V en courant alternatif ou 30 V en courant continu, auquel cas une indication que l'appareillage de commande doit être TBTS uniquement est exigée.

6.4.21 Si le bloc de jonction n'est pas fourni avec le luminaire, le texte suivant doit être marqué sur l'emballage ou la feuille d'instructions:

"Bloc de jonction non inclus. L'installation doit être effectuée par une personne qualifiée."

6.4.22 Les fabricants de luminaires doivent fournir des informations sur la protection exigée pour le câblage réseau sur le site des luminaires qui utilisent des sources de lumière qui émettent des UV sur l'isolant du câblage réseau. Les informations doivent en substance comporter ce qui suit:

"Pour l'installation, l'utilisation de gaines supplémentaires résistant aux UV est exigée pour les câbles d'alimentation réseau sur le site qui ne sont pas résistants aux UV (en particulier certains câbles sans halogène à faible dégagement de fumée)."

NOTE Il n'est pas prévu que les sources de lumière pour éclairage général autres que les lampes fluorescentes, aux halogénures métalliques et au mercure haute pression émettent des niveaux d'UV qui puissent endommager l'isolant des câbles.

6.4.23 Pour les appliques murales fixes et les luminaires portatifs pour montage en applique qui utilisent un câble ou cordon externe souple de plus de 30 cm, les instructions du fabricant doivent contenir en substance le texte suivant: "Pour réduire le risque d'étranglement, le câblage souple raccordé à ce luminaire doit être fixé efficacement au mur si le câblage se situe dans le volume d'accessibilité au toucher".

6.4.24 Les luminaires doivent être fournis avec des informations relatives aux instructions du fabricant pour le remplacement ou le non-remplacement de l'appareillage de commande du luminaire, ainsi qu'avec toute maintenance ou tout réglage opérationnel associé de ces pièces.

Les luminaires équipés d'un appareillage de commande doivent être fournis avec les informations suivantes, selon le cas:

a) Appareillage de commande non remplaçable:

Pour les luminaires dont l'appareillage de commande est une pièce non remplaçable, les informations suivantes doivent être données: "L'appareillage de commande de ce luminaire est un composant non remplaçable; lorsque l'appareillage de commande atteint sa fin de vie, le luminaire entier doit être remplacé".

À la place du texte, le pictogramme de la Figure 28 peut être utilisé pour le marquage sur le produit ou sur l'emballage et doit être expliqué dans les instructions du fabricant fournies avec le luminaire ou par un lien dans les instructions vers l'emplacement de ces informations sur le site web des fabricants.

NOTE 1 L'utilisation d'un code QR ou d'un lien similaire peut convenir à cette exigence.



NOTE Ce pictogramme comprend le symbole suivant: ISO 7000-2795:2006-08 (modifié).

Figure 28 – Pictogramme pour un appareillage de commande non remplaçable

De plus, pour les luminaires pour lesquels l'accès à l'appareillage de commande (pour le réglage des paramètres de fonctionnement, par exemple) doit être empêché, les informations suivantes doivent être données: "L'appareillage de commande de ce luminaire est un composant non remplaçable, ne pas tenter d'accéder à l'appareillage".

b) Appareillage de commande non remplaçable par l'utilisateur final:

Pour les luminaires dont l'appareillage de commande est une pièce non remplaçable par l'utilisateur, les informations suivantes doivent être données: "Il convient de confier la maintenance de l'appareillage de commande de ce luminaire uniquement au fabricant, à son agent de maintenance ou à une personne qualifiée équivalente".

À la place du texte, le pictogramme de la Figure 29 peut être utilisé pour le marquage sur le produit ou sur l'emballage et doit être expliqué dans les instructions du fabricant fournies avec le luminaire ou par un lien dans les instructions vers l'emplacement de ces informations sur le site web des fabricants.

NOTE 2 L'utilisation d'un code QR ou d'un lien similaire peut convenir à cette exigence.

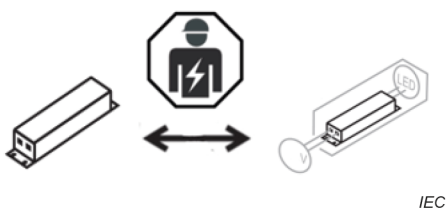

NOTE Ce pictogramme comprend le symbole suivant: IEC 60417-6182:2013-09.

Figure 29 – Pictogramme pour un appareillage de commande non remplaçable par l'utilisateur final

De plus, pour les luminaires pour lesquels l'accès de l'utilisateur à l'appareillage de commande (pour le réglage des paramètres de fonctionnement, par exemple) doit être empêché, les informations suivantes doivent être données: "L'appareillage de commande de ce luminaire est un composant non remplaçable par l'utilisateur final, l'accès à l'appareillage doit uniquement être effectué par le fabricant, son agent de service ou une personne qualifiée équivalente".

c) Appareillage de commande remplaçable:

Pour les luminaires dont l'appareillage de commande est une pièce remplaçable qui peut être remplacée par l'utilisateur du luminaire, les informations suivantes doivent être données: "L'appareillage de commande de ce luminaire peut être remplacé conformément aux recommandations données par le fabricant du luminaire".

NOTE 3 Le fabricant du luminaire peut inclure, sur demande, la référence du type des composants qui conviennent à la maintenance du luminaire.

À la place du texte, le pictogramme de la Figure 30 peut être utilisé pour le marquage sur le produit ou sur l'emballage et doit être expliqué dans les instructions du fabricant fournies avec le luminaire ou par un lien dans les instructions vers l'emplacement de ces informations sur le site web du fabricant.

NOTE 4 L'utilisation d'un code QR ou d'un lien similaire peut convenir à cette exigence.



Figure 30 – Pictogramme pour un appareillage de commande remplaçable

De plus, pour les luminaires pour lesquels l'accès de l'utilisateur à l'appareillage de commande (pour le réglage des paramètres de fonctionnement, par exemple) est admis, des instructions pour le réglage ou l'ajustement des appareillages doivent être données.

6.5 Essai de marquage

La conformité aux exigences des 6.2, 6.3 et 6.4 est vérifiée par examen et par l'essai suivant:

La durabilité du marquage est vérifiée en essayant de l'effacer, en le frottant légèrement pendant 15 s avec un chiffon imbibé d'eau et après séchage, pendant encore 15 s avec un chiffon imbibé de white-spirit et en effectuant un examen après avoir procédé aux essais spécifiés à l'Article 14.

Après l'essai, le marquage doit être lisible, les étiquettes de marquage ne doivent pas être facilement détachables et ne doivent pas présenter d'ondulations.

NOTE Le white-spirit utilisé est habituellement constitué de solvant hexane ayant une teneur d'au maximum 0,1 % en volume en produits aromatiques, de 29 % en kauri-butanol, une température d'ébullition initiale d'approximativement 65 °C, un point sec de 69 °C approximativement et une masse volumique d'environ 0,68 g/cm³.

7 Construction

7.1 Généralités

L'Article 7 spécifie les exigences générales de construction des luminaires. Voir aussi Annexe J.

7.2 Composants remplaçables

Les luminaires qui comportent des composants ou des parties destinés à être remplacés ou utilisés doivent être conçus de telle sorte qu'il existe un espace suffisant pour permettre le remplacement ou l'utilisation de ces composants ou parties sans difficulté et sans compromettre la sécurité.

La conformité est vérifiée par examen et par le remplacement des composants.

NOTE Les composants scellés et les parties rivetées ne sont pas des composants remplaçables.

7.3 Passages de fils

Les passages de fils doivent être lisses et exempts de bords vifs, de bavures, d'ébarbures ou de défauts analogues, qui peuvent provoquer l'abrasion de l'enveloppe isolante du câblage. Les vis à pointe métalliques et analogues ne doivent pas dépasser dans les passages de fils.

La conformité est vérifiée par examen et, si nécessaire, par démontage et remontage du luminaire.

7.4 Douilles

7.4.1 Les exigences relatives à la sécurité électrique des douilles intégrées doivent être celles qui s'appliquent au luminaire considéré comme un tout, douille et lampe étant en position complètement assemblée comme en utilisation normale.

En complément, les douilles intégrées doivent, lorsqu'elles sont montées dans le luminaire, satisfaire aux exigences concernant la sécurité pendant l'insertion de la lampe, comme cela est spécifié dans la norme appropriée pour les douilles.

7.4.2 Les raccordements du câblage aux contacts d'une douille intégrée peuvent être réalisés par toute méthode assurant un contact électrique fiable pendant toute la durée de vie de la douille.

7.4.3 Les luminaires pour lampes tubulaires fluorescentes prévus pour être montés de bout en bout doivent être conçus de façon que la lampe dans le luminaire du milieu d'une rangée puisse être changée sans dérégler un autre luminaire. Dans les luminaires à plusieurs lampes tubulaires fluorescentes, le changement d'une lampe quelconque ne doit pas porter atteinte à la sécurité des autres lampes.

La conformité aux exigences des 7.4.1 à 7.4.3 est vérifiée par examen.

7.4.4 Les douilles mises en place par l'utilisateur doivent être prévues pour un positionnement facile et correct.

La distance entre les deux douilles fixes d'une lampe à fluorescence prévue pour être placée dans une position fixe doit être conforme à la feuille de norme correspondante de l'IEC 60061-2 ou (si l'IEC 60061-2 ne s'applique pas), aux instructions de montage du fabricant des douilles. Les douilles pour lampes à filament de tungstène et les douilles pour lampes fluorescentes à culot unique doivent être correctement fixées au corps du luminaire. L'appareil de fixation des douilles doit avoir une résistance mécanique adéquate de manière à résister au maniement sans précautions qui peut être prévu en usage normal. Ces exigences s'appliquent aux douilles mises en position par l'utilisateur et à celles mises en position par le fabricant du luminaire.

La conformité est vérifiée par examen, par mesurage et, s'il y a lieu, par les essais mécaniques suivants.

a) *Les douilles pour une lampe à fluorescence, avec un culot d'essai en position, sont soumises, pendant 1 min, à une pression appliquée au centre du culot, dans la direction de son axe, de:*

- 15 N pour douilles G5;
- 30 N pour douilles G13;
- 30 N pour douilles des lampes fluorescentes à culot unique (G23, G10q, GR8, etc.). Pour les autres douilles, les valeurs sont à l'étude.

NOTE Pour ces essais, les culots de lampes normalisées peuvent être utilisés comme les culots d'essai.

Après l'essai, la distance entre les douilles doit être conforme aux indications de la feuille de norme correspondante de l'IEC 60061-2 et la douille ne doit présenter aucun dommage. Le culot d'essai pour cet essai doit être conforme aux feuilles de norme suivantes de l'IEC 60061-3:

- 7006-47C pour les douilles G5;
- 7006-60C pour les douilles G13;
- les culots d'essai pour les autres douilles sont à l'étude.

Après les essais sur les douilles pour lampes fluorescentes à culot unique, la douille ne doit pas avoir changé de position et l'appareil de fixation ne doit pas présenter de déformation permanente de façon que la lampe, lors de sa réinsertion, revienne à sa position prévue.

b) *Les consoles en applique pour douilles à vis Edison ou baïonnette sont soumises à l'essai pendant 1 min aux moments de flexion suivants:*

- pour les douilles E14 et B15 1,2 Nm;
- pour les douilles E26, E27 et B22 2,0 Nm;
- pour les douilles E39 et E40 4,0 Nm.

Après l'essai, la douille ne doit pas s'être déplacée de sa position et l'appareil de fixation ne doit pas présenter de déformation permanente, de façon que, lorsque la lampe est réintroduite, elle se place dans la position prévue.

7.4.5 Pour les luminaires avec amorces, la tension de crête de l'impulsion qui traverse les contacts des douilles qui font partie du circuit de cette tension d'impulsion ne doit pas être supérieure à la tension d'impulsion marquée sur la douille ou, en l'absence d'un tel marquage, ne doit pas être supérieure à:

- pour les douilles de tension assignée 250 V 2,5 kV;
- pour les douilles à vis Edison de tension assignée 500 V 4 kV;
- pour les douilles à vis Edison de tension assignée 750 V 5 kV.

La conformité est vérifiée par mesurage de la tension traversant les contacts de la douille durant l'essai d'impulsion selon le 12.2.3 pour les luminaires avec amorces.

7.4.6 Dans les luminaires avec amorces comprenant des douilles à vis Edison, le contact central de la douille doit être relié au conducteur qui fournit la tension d'impulsion.

La conformité est vérifiée par examen.

7.4.7 Les parties isolantes des douilles et des fiches incorporées aux luminaires pour conditions sévères d'emploi doivent être en matériau résistant aux courants de cheminement.

La conformité est vérifiée par l'essai du 15.4.

7.4.8 Les connecteurs de lampes doivent satisfaire à toutes les exigences pour les douilles, autres que celles relatives au maintien de la lampe en position. Les moyens de retenue de la lampe doivent être assurés par d'autres parties du luminaire.

La conformité est vérifiée par examen et par l'essai exigé des 7.4.1 à 7.4.7.

NOTE La différence entre les connecteurs de lampes et les douilles est clairement identifiée sur les feuilles de caractéristiques correspondantes de la série IEC 60061.

7.4.9 Les culots ou les socles initialement développés pour les lampes TBT à culot unique ne doivent pas être utilisés dans les luminaires destinés à être utilisés avec des lampes tungstène-halogène d'éclairage général à des tensions assignées supérieures à 50 V.

NOTE Exemples de tels systèmes TBT: G4, GU4, GY4, GX5.3, GU5.3, G6.35, GY6.35, GU7 et G53.

Les luminaires destinés à être utilisés uniquement avec des lampes GU10 (avec réflecteur aluminisé) doivent être équipés de douilles pour lampes GU10 uniquement.

La conformité est vérifiée par examen.

7.4.10 L'utilisation d'une ou de plusieurs sources de lumière, conçues pour être connectées par une douille ou un connecteur conformément à la série IEC 60061, mais utilisées sans la douille ou le connecteur correspondant et avec les connexions électriques effectuées d'une autre façon (par exemple, avec le câble soudé directement sur les broches), n'est pas autorisée.

La conformité est vérifiée par examen.

7.5 Douilles de starter

Les douilles de starter dans les luminaires autres que ceux de la classe II doivent accepter des starters conformes à l'IEC 60155.

Pour les luminaires de classe II où le starter est accessible au doigt d'épreuve normalisé (calibre d'essai B selon l'IEC 61032:1997, Figure 2), lorsque le luminaire est complètement monté pour l'utilisation, ou ouvert pour le remplacement des lampes ou des starters, la douille du starter doit être d'un modèle acceptant uniquement les starters conformes aux exigences pour les starters des luminaires de classe II données dans l'IEC 60155.

La conformité est vérifiée par examen.

7.6 Blocs de jonction

Si les luminaires sont équipés de câbles de raccordement (sorties) nécessitant un bloc de jonction séparé pour le raccordement au câblage fixe, la place nécessaire à ce bloc de jonction doit être prévue à l'intérieur du luminaire, ou dans une boîte fournie avec le luminaire, ou définie par le fabricant.

Cette exigence s'applique aux blocs de jonction pour câbles de raccordement (sorties) dont la section nominale ne dépasse pas 2,5 mm².

La conformité est vérifiée par des mesurages et par un essai d'installation, en utilisant un bloc de jonction pour chaque jeu de deux conducteurs à relier, comme cela est représenté à la Figure 31, et des câbles de l'installation fixe d'environ 80 mm de longueur. Les dimensions des blocs de jonction sont celles qui sont spécifiées par le fabricant ou, en l'absence d'une telle spécification, égales à 10 mm × 20 mm × 25 mm.

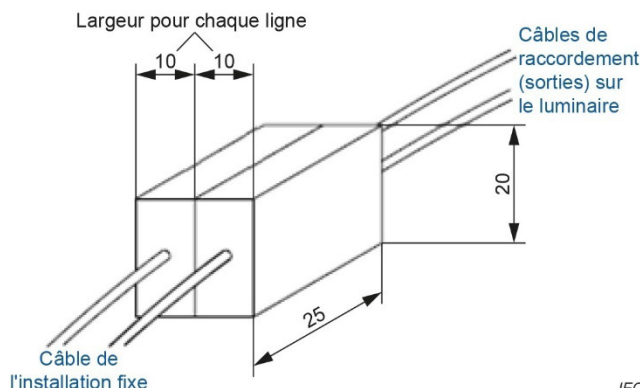

Figure 31 – Bloc de jonction pour essai de pose de luminaire à câbles de raccordement (sorties)

Des blocs de jonction non fixés sont admis s'ils sont conçus et isolés de telle sorte que les lignes de fuite et distances dans l'air conformes à l'Article 13 soient toujours assurées, quelle que soit la position du bloc de jonction, et que tout dommage au câblage interne soit évité.

7.7 Bornes et raccordement au réseau

7.7.1 Dans les luminaires portatifs de classe I et de classe II et dans les luminaires fixes de classe I et de classe II qui sont fréquemment réglés, des précautions convenables doivent être prises pour éviter que des parties métalliques deviennent des parties actives dangereuses en raison du détachement d'un câble ou d'une vis. Cette exigence est applicable à toutes les bornes (y compris les bornes d'alimentation).

NOTE L'exigence peut être respectée en immobilisant les fils adjacents à leur entrée dans les bornes, en laissant un espace de dimension adéquate pour les bornes, en utilisant une enveloppe en matériau isolant, ou à l'aide d'un recouvrement isolant de l'enveloppe.

Exemples de méthodes considérées comme pouvant éviter qu'un fil ne se détache:

- les fils sont retenus aux bornes par un dispositif d'arrêt de traction adjacent aux bornes;
- le conducteur est serré par ressort du type borne sans vis;
- le conducteur du fil est fixé avant soudure;
- les fils sont toronnés ensemble de manière fiable;
- les fils sont fixés ensemble à l'aide d'un ruban isolant, de gaines ou dispositifs similaires;
- le conducteur du fil est inséré dans le trou d'un circuit imprimé, plié et soudé, le trou ayant un diamètre légèrement supérieur à celui du conducteur;
- le conducteur du fil est enroulé de manière sûre autour de la borne au moyen d'un outil spécial (voir Figure 53);
- le conducteur du fil est serti sur la borne au moyen d'un outil spécial (voir Figure 53).

Les méthodes a) à h) s'appliquent au câblage interne et les méthodes a) et b) aux cordons flexibles externes pouvant être recâblés.

La conformité est vérifiée par examen fondé sur la présomption qu'un seul conducteur peut se détacher au même moment.

7.7.2 Les bornes de raccordement au réseau doivent être placées ou protégées de telle sorte que, si un fil d'un conducteur toronné s'échappe d'une borne lorsque les conducteurs sont en place, il n'y ait aucun risque de contact entre les parties actives dangereuses et les parties métalliques accessibles au doigt d'épreuve normalisé (calibre d'essai B selon l'IEC 61032:1997, Figure 2), lorsque le luminaire est complètement monté pour l'utilisation, ou est ouvert pour le remplacement des sources de lumière remplaçables ou des starters.

La conformité est vérifiée par examen et par l'essai suivant.

Une longueur d'isolant de 8 mm est enlevée de l'extrémité d'un conducteur souple ayant la plus grande section spécifiée à l'Article 8. Un fil du conducteur toronné est laissé libre et le reste est introduit complètement et serré dans la borne. Le fil libre est courbé, sans faire la moindre déchirure à l'isolation, dans toutes les directions, mais sans former d'angle aigu autour des cloisons isolantes.

Le fil libre d'un conducteur relié à une borne active dangereuse ne doit pas toucher une partie métallique accessible ou reliée à une partie métallique accessible, et le fil libre d'un conducteur relié à une borne de terre ne doit pas toucher de partie active dangereuse.

Cet essai n'est pas applicable aux douilles qui ont satisfait, séparément, aux exigences d'une norme appropriée de l'IEC et aux bornes des composants dans lesquels le mode de construction justifie une longueur plus courte du fil libre.

7.7.3 Les bornes pour cordon d'alimentation doivent être prévues pour être raccordées au moyen de vis, écrous ou appareils d'efficacité équivalente.

Les câbles de raccordement (sorties) doivent satisfaire aux exigences du 8.3.

NOTE 1 Pour les luminaires conçus pour être branchés au moyen de conducteurs rigides (solides ou toronnés), les bornes sans vis du type à serrage par ressort sont considérées comme des appareils efficaces, même pour une connexion de mise à la terre. Il n'y a actuellement aucune exigence qui permet d'utiliser de telles bornes pour la connexion des cordons d'alimentation.

NOTE 2 Pour les luminaires conçus pour être connectés au moyen d'un cordon d'alimentation et ayant un courant assigné qui ne dépasse pas 3 A, les connexions soudées, serties et analogues, y compris les connexions à encliquetage, sont considérées comme des appareils efficaces, même pour une connexion de mise à la terre. Les connexions analogues incluent les bornes sans vis, à percement d'isolant ou les bornes à verrouillage par déplacement de l'isolant.

NOTE 3 Pour les luminaires dont le courant assigné est supérieur à 3 A, les connecteurs à encliquetage sont autorisés si le raccordement peut aussi être effectué sans se servir d'une prise femelle, au moyen, par exemple, d'un raccordement vissé dans un trou fileté prévu dans la languette.

7.7.4 Méthode et matériau de soudage: Le conducteur doit être constitué de fils rigides ou toronnés en cuivre. Pour les fils fins, une fêrule (embout) peut être utilisée.

La méthode de soudage doit être uniquement le soudage par points.

Les connexions soudées peuvent être utilisées uniquement dans le cas de connexions de types Y et Z.

Les connexions soudées doivent résister aux essais mécanique, électrique et d'échauffement en utilisation normale.

La conformité est vérifiée par examen et par les essais suivants.

a) *Essai mécanique*

Appliquer l'essai du 17.5.2.

Si le fil est fixé par un dispositif d'arrêt de traction, l'essai mécanique n'est pas applicable.

b) *Essai électrique*

Appliquer les essais du 17.5.3.

c) *Essai d'échauffement*

Appliquer les essais des 17.5.3.3.4 et 17.5.3.3.5.

7.7.5 Les bornes autres que celles pour raccordement au réseau, qui ne sont pas couvertes par des normes séparées pour composants, doivent satisfaire aux exigences de l'Article 16 et de l'Article 17.

Les bornes des douilles, des interrupteurs et des composants similaires utilisés pour la connexion multiple du câblage interne doivent avoir des dimensions appropriées et ne doivent pas être utilisées pour la connexion du câblage externe

La conformité est vérifiée par examen et au par les essais de l'Article 16 et de l'Article 17.

7.7.6 Lorsque le câblage externe (ou le cordon d'alimentation) ne peut résister aux températures atteintes à l'intérieur du luminaire, un raccordement doit être prévu au point d'entrée du câblage externe dans le luminaire, pour l'emploi d'un câblage résistant à la chaleur après ce point, ou des pièces résistant à la chaleur doivent être fournies avec le luminaire, afin de couvrir la partie du câblage placée à l'intérieur qui dépasse la limite de température du câblage.

La conformité est vérifiée par examen.

7.7.7 Si, durant l'installation ou l'entretien d'un luminaire, les connexions électriques sont exécutées au moyen d'une fiche multipolaire et d'un socle, les connexions dangereuses doivent être empêchées.

La conformité est vérifiée par examen et en essayant de créer des connexions dangereuses, par exemple en modifiant les positions de la fiche. La force appliquée sur la fiche pendant les essais de conformité doit prendre en compte toutes les forces de 30 N au maximum dans toutes les directions.

7.8 Interrupteurs

Les interrupteurs doivent être calibrés convenablement et fixés de façon à ne pas pouvoir tourner ni être enlevés à la main.

Les interrupteurs montés sur câbles ou cordons souples ainsi que les douilles de lampe commutées ne doivent pas être utilisés hors de modèles de luminaires ordinaires, à moins que le degré de protection de l'interrupteur contre la pénétration des poussières, des corps solides ou de l'humidité ne soit conforme à la classification du luminaire.

Pour les luminaires prévus pour être utilisés sur une alimentation avec polarités et lorsque le luminaire est équipé d'un interrupteur unipolaire, l'interrupteur doit être relié au côté actif de l'alimentation ou au côté différent de celui identifié comme étant le neutre.

Les interrupteurs mécaniques, lorsqu'ils sont incorporés ou fournis avec le luminaire, doivent satisfaire aux exigences de l'IEC 61058-1-1 pour les interrupteurs pour appareils ou de l'IEC 60669-1 pour les interrupteurs pour installations électriques fixes domestiques et analogues.

Pour les interrupteurs conformes à l'IEC 61058-1-1, le nombre minimal de cycles de fonctionnement doit être de 10 000.

Les interrupteurs électroniques, lorsqu'ils sont incorporés ou fournis avec le luminaire, doivent satisfaire aux exigences de l'IEC 61058-1-2 pour les interrupteurs pour appareils ou de l'IEC 60669-2-1 pour les interrupteurs pour installations électriques fixes domestiques et analogues.

Les interrupteurs dans les câbles souples (interrupteurs pour câbles souples) doivent satisfaire aux exigences de l'IEC 61058-2-1.

Les exigences ci-dessus ne sont pas applicables dans le cas où des interrupteurs fonctionnent dans des circuits TBT avec une puissance inférieure à 15 W et un courant inférieur à 0,5 A.

NOTE La limite de 15 W est obtenue à partir de l'IEC TS 60695-1-14.

La conformité est vérifiée par mesurage et par examen.

7.9 Recouvrements et manchons isolants

7.9.1 Les recouvrements et gaines isolants doivent être conçus pour être maintenus en position de façon fiable lorsque les interrupteurs, douilles, bornes, câbles et éléments analogues ont été montés.

NOTE Des résines aut durcissantes, telles les résines époxy, peuvent être employées pour fixer ces revêtements.

La conformité est vérifiée par examen et par essai manuel.

7.9.2 Les revêtements, gaines et parties similaires isolants doivent avoir une résistance mécanique, électrique et thermique adéquate.

La conformité est vérifiée par examen, par essai manuel et par l'essai de rigidité diélectrique conformément à l'Article 12. Les propriétés thermiques des câbles et des gaines sont vérifiées conformément à l'Article 14. Les gaines qui résistent à la chaleur utilisées pour recouvrir les câbles atteignant une température dépassant les valeurs du Tableau 22 doivent satisfaire aux exigences de la série IEC 60684, compte tenu de la température mesurée sur le câble en question. La gaine doit résister à une température dépassant de 20 °C celle mesurée sur le câble, ou bien supporter l'essai suivant.

- a) *Trois éprouvettes de la gaine, d'environ 15 cm de longueur, sont soumises à l'essai d'humidité du 11.3 et par la suite aux essais de résistance d'isolement et de rigidité diélectrique, conformément à l'Article 12. Un conducteur approprié, en cuivre non isolé ou une tige métallique est passé(e) au travers des éprouvettes, et l'extérieur est recouvert d'une feuille métallique, de telle manière qu'aucun contournement ne puisse se produire aux extrémités des échantillons. Le mesurage de la résistance d'isolement et de la rigidité diélectrique est alors effectué entre le conducteur en cuivre ou la tige métallique et la feuille métallique.*
- b) *Après avoir retiré les conducteurs en cuivre/tiges métalliques et feuilles métalliques, les éprouvettes sont placées dans une étuve pendant 240 h, à une température de $T + 20$ °C, T étant la température mesurée sur le câble.*
- c) *Il est admis de laisser les éprouvettes se refroidir jusqu'à la température de la pièce, et elles sont ensuite préparées comme cela est indiqué au point a) ci-dessus.*

Le mesurage de la résistance d'isolement et de la rigidité diélectrique est alors effectué entre le conducteur en cuivre ou la tige métallique et la feuille métallique.

La conformité est vérifiée par les valeurs de la résistance d'isolement et les tensions d'essai spécifiées dans le Tableau 15 et le Tableau 16.

7.10 Double isolation et isolation renforcée

7.10.1 Pour les luminaires de classe II à enveloppe métallique, le contact entre:

- les surfaces de montage et les parties à isolation principale seulement; et
- les parties métalliques accessibles et l'isolation principale;

doit être effectivement évité.

NOTE 1 Ceci n'exclut pas l'utilisation de conducteurs nus si une protection convenable est procurée.

Le câblage à étudier comprend les câblages interne et externe du luminaire et le câblage fixe de l'installation.

Les luminaires fixes de la classe II doivent être conçus pour que le degré de protection imposé contre les chocs électriques ne soit pas compromis par suite de l'installation du luminaire, par exemple par contact avec des canalisations ou gaines métalliques de câbles.

Les condensateurs ne doivent pas être raccordés entre les parties actives et le corps des luminaires à enveloppe métallique de classe de protection II, à l'exception des condensateurs d'antiparasitage de type Y conformément au Tableau 4. Si des interrupteurs sont utilisés, ils doivent satisfaire aux exigences du 7.8.

NOTE 2 Le contact entre les pièces métalliques accessibles et l'isolation principale du câblage interne peut être évité par des gaines ou éléments analogues qui satisfont aux exigences pour une isolation supplémentaire.

La conformité est vérifiée par examen.

7.10.2 Toute discontinuité d'assemblage d'une largeur supérieure à 0,3 mm dans une isolation supplémentaire ne doit pas coïncider avec une discontinuité quelconque dans une isolation principale et aucune des discontinuités ne doit, dans une isolation renforcée, donner un accès direct aux parties actives dangereuses.

Des ouvertures plus larges que 0,3 mm dans la double isolation ou l'isolation renforcée doivent être conçues de telle sorte que les parties actives dangereuses ne puissent pas être touchées avec la broche conique du calibre d'essai 13 représentée dans l'IEC 61032:1997, Figure 9.

NOTE Pour assurer une ventilation forcée efficace ou une évacuation d'eau du luminaire, il peut être nécessaire de prévoir des ouvertures dans la double isolation ou l'isolation renforcée.

En complément, la conformité doit être assurée avec le degré de protection exigé contre les chocs électriques, selon la classification IP du luminaire.

La conformité est vérifiée par examen et mesurage à l'aide du ou des calibres correspondants en fonction du degré de protection exigé contre les chocs électriques.

7.10.3 Les parties des luminaires de classe II qui sont utilisées comme isolation supplémentaire ou renforcée doivent:

- soit être fixées de telle manière qu'elles ne puissent être enlevées sans être sérieusement endommagées;
- soit ne pas pouvoir être replacées en position incorrecte.

Lorsqu'il est fait usage de gaines comme isolation supplémentaire sur le câblage interne et lorsque des recouvrements isolants sont utilisés dans les douilles comme isolation supplémentaire sur les câblages externe ou interne, les gaines et recouvrements doivent être maintenus en position par des moyens efficaces.

Une gaine est considérée comme étant fixée par des moyens efficaces s'il est nécessaire de la casser ou de la couper pour l'enlever, ou si elle est fixée aux deux extrémités, ou si son déplacement sur le câblage interne est limité par des composants voisins. Un recouvrement est considéré comme fixé par des moyens efficaces s'il peut seulement être enlevé par bris ou découpage ou par démontage de la douille.

Les parties telles qu'un tube en matériau isolant équipé d'une collerette et utilisé comme gaine à l'intérieur d'un raccord de douille sont considérées comme constituant l'isolation supplémentaire du câblage externe ou interne si elles ne peuvent être retirées que par démontage de la douille.

La conformité est vérifiée par examen et par essai manuel.

Le recouvrement des enveloppes métalliques par une couche de vernis ou par toute autre matière sous forme d'une couche pouvant être facilement enlevée par grattage n'est pas considéré comme satisfaisant à cette exigence.

7.10.4 Impédance de protection: Les parties séparées par une isolation (par exemple lorsqu'une isolation principale, supplémentaire, double ou renforcée est exigée) peuvent être pontées (pont conducteur) par des résistances. Pour l'isolation principale ou l'isolation supplémentaire, il peut s'agir d'une seule résistance, pour chaque couche d'isolation. Pour une double isolation ou une isolation renforcée, elles doivent consister au minimum en deux résistances séparées de même valeur assignée, connectées en série, chacune assignée à la tension totale de service de sorte qu'il est peu probable que leur impédance change significativement pendant la durée de vie individuelle du luminaire.

Elles doivent satisfaire aux exigences de l'Article G.10 de l'IEC 62368-1:2018.

Les parties séparées par une isolation (par exemple lorsqu'une isolation principale, supplémentaire, double ou renforcée est exigée) peuvent être pontées par un certain nombre de condensateurs Y en série selon le Tableau 4.

Les condensateurs Y1, Y2 et Y4 doivent être conformes aux exigences appropriées de l'IEC 60384-14.

Tableau 4 – Vue d'ensemble des condensateurs Y exigés

Tension alternative efficace du réseau ^a	Catégorie de surtension	Type d'isolation	Type de condensateur	Nombre exigé de condensateurs
$U \leq 150 \text{ V}$	II	B ou S	Y4	1
$U \leq 150 \text{ V}$	II	B ou S	Y2	1
$U \leq 150 \text{ V}$	II	B ou S	Y1	1
$U \leq 150 \text{ V}$	II	D ou R	Y4	2
$U \leq 150 \text{ V}$	II	D ou R	Y2	2
$U \leq 150 \text{ V}$	II	D ou R	Y1	1
$150 \text{ V} < U \leq 300 \text{ V}$	II	B ou S	Y2	1
$150 \text{ V} < U \leq 300 \text{ V}$	II	B ou S	Y1	1
$150 \text{ V} < U \leq 300 \text{ V}$	II	D ou R	Y2	2
$150 \text{ V} < U \leq 300 \text{ V}$	II	D ou R	Y1	1
$300 \text{ V} < U \leq 500 \text{ V}$	II	B ou S	Y2	1
$300 \text{ V} < U \leq 500 \text{ V}$	II	B ou S	Y1	1
$300 \text{ V} < U \leq 500 \text{ V}$	II	D ou R	Y2	2
$300 \text{ V} < U \leq 500 \text{ V}$	II	D ou R	Y1	1

Légende	
B	isolation principale
S	isolation supplémentaire
R	isolation renforcée
D	double isolation
^a	Dans le cas de condensateurs connectés entre des parties actives de circuits isolés du réseau et des parties accessibles, la tension à prendre en compte est celle indiquée dans le Tableau T.1.

7.11 Connexions électriques et parties conductrices

7.11.1 Les connexions électriques doivent être conçues de sorte que la pression de contact ne se transmette pas au travers des matériaux isolants autres que les matériaux céramiques, le mica pur ou d'autres matériaux présentant des caractéristiques au moins équivalentes, sauf si les parties métalliques sont suffisamment élastiques pour compenser un éventuel retrait du matériau isolant.

La conformité est vérifiée par examen.

7.11.2 Les vis autotaraudeuses ne doivent pas être utilisées pour la connexion de parties transportant le courant, sauf si ces vis maintiennent ces parties directement par contact les unes avec les autres et comportent un dispositif de verrouillage approprié.

Les vis autotaraudeuses et les vis à tôle ne doivent pas être utilisées pour raccorder entre elles des parties conductrices en métal mou, ou susceptible de fluer, comme le zinc ou l'aluminium.

Les vis à tôle peuvent servir à assurer la continuité de terre de protection lorsqu'il n'est pas nécessaire de déplacer la connexion en usage normal.

La conformité est vérifiée par examen.

EXEMPLE Voir Figure 32.

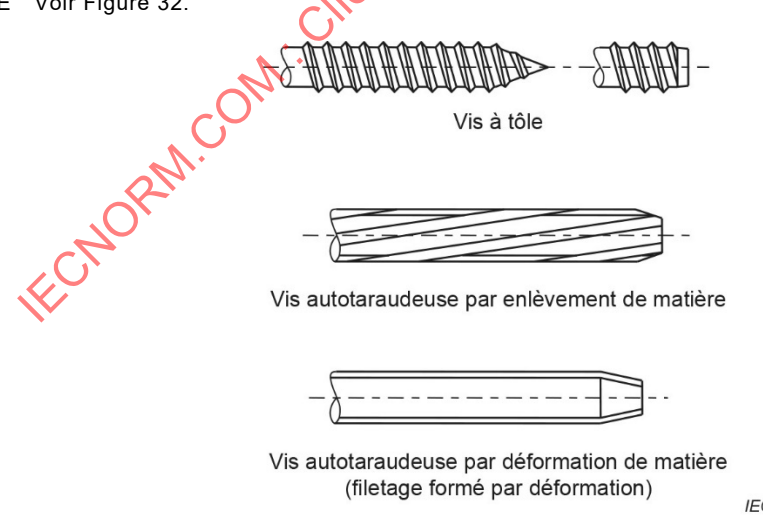

Figure 32 – Exemples de vis à tôle et de vis autotaraudeuses par enlèvement ou déformation de matière

7.11.3 Les vis et rivets, utilisés à la fois pour des connexions électriques et mécaniques, doivent être protégés contre le desserrage. Des rondelles élastiques peuvent assurer un blocage satisfaisant. Pour les rivets, une tige non circulaire ou une encoche appropriée peuvent suffire.

Les résines de scellement qui se ramollissent au chauffage assurent un blocage satisfaisant seulement pour des connexions à vis non soumises à torsion en utilisation normale.

La conformité est vérifiée par examen et par un essai manuel.

7.11.4 Les parties transportant le courant doivent être réalisées en cuivre, dans un alliage constitué d'au moins 50 % de cuivre ou dans un matériau qui présente des caractéristiques au moins équivalentes. Cette exigence n'est pas applicable aux parties conductrices des circuits d'alimentation TBTF, TBTS ou TBTP lorsque:

- la puissance de la charge est inférieure à 15 W dans les conditions normales de fonctionnement, et
- le courant dans toutes les conditions de charge (y compris les courts-circuits) ne doit pas être supérieur à 2 A.

NOTE 1 Les conducteurs en aluminium peuvent être acceptés comme ayant des caractéristiques au moins équivalentes, à condition que leur emploi soit examiné cas par cas.

NOTE 2 La limite de 15 W est obtenue à partir de l'IEC TS 60695-1-14.

La présente exigence n'est pas applicable aux vis qui ne conduisent pas essentiellement de courant telles que les vis des bornes.

Les parties conductrices doivent résister à, ou être suffisamment protégées contre, la corrosion.

Le cuivre et les alliages de cuivre contenant au moins 50 % de cuivre sont réputés satisfaire à cette exigence.

NOTE 3 Plus d'informations relatives à l'utilisation d'aimants permanents comme parties transportant le courant sont données en J.11 g).

La conformité est vérifiée par examen et, si nécessaire, par analyse chimique.

7.11.5 Les parties conductrices ne doivent pas être en contact direct avec la surface de montage ou du bois.

La conformité est vérifiée par examen.

7.11.6 Les systèmes de contact électromécaniques doivent résister aux contraintes électriques qui se produisent en utilisation normale.

La conformité est vérifiée en soumettant les systèmes de contacts électromécaniques à 100 opérations exécutées à une vitesse correspondant à un usage pratique (une opération est soit l'établissement soit la coupure du contact). L'essai est effectué à tension assignée alternative et le courant d'essai doit être de 1,25 fois le courant assigné du système de contact électrique. Le facteur de puissance de la charge doit être approximativement de 0,6 à moins qu'un courant assigné différent ne soit marqué pour les charges résistives, auquel cas le facteur de puissance de la charge doit être égal à l'unité.

Lorsqu'un luminaire est marqué à la fois pour les charges résistives et inductives, il doit être soumis aux essais avec les facteurs de puissance unité et 0,6.

Avant et après les essais, les systèmes de contacts électromécaniques doivent être chargés avec un courant égal à 1,5 fois la valeur assignée, et la chute de tension aux bornes de chaque contact ne doit pas dépasser 50 mV.

À la suite de ces essais, le système de contacts électromécaniques doit résister à un essai de rigidité diélectrique effectué conformément au 12.2.

Après l'essai, les échantillons ne doivent présenter:

- *ni usure compromettant leur utilisation ultérieure;*
- *ni détérioration des enveloppes ou des cloisons;*
- *ni relâchement des connexions électriques ou mécaniques.*

L'essai mécanique du 7.14.3 et l'essai électrique des systèmes de contacts électromécaniques sont effectués simultanément.

7.12 Vis, connexions (mécaniques) et presse-étoupes

7.12.1 Les vis et connexions mécaniques, dont la défaillance peut conduire le luminaire à devenir dangereux, doivent supporter les contraintes mécaniques qui surviennent en utilisation normale.

Les vis ne doivent pas être réalisées dans un matériau qui est mou ou susceptible de fluer.

NOTE 1 Des exemples de ce type de matériau sont le zinc, certaines catégories d'aluminium et plusieurs thermoplastiques.

Les vis qui sont manœuvrées lors de la maintenance ne doivent pas être en matériau isolant si leur remplacement par une vis métallique peut porter atteinte à l'isolation supplémentaire ou à l'isolation renforcée.

Les vis utilisées pour assurer la continuité de terre de protection, par exemple les vis de fixation pour les appareillages de commande ou autres composants, doivent être conformes à l'exigence du premier alinéa du 7.12.1. Au moins une vis qui retient l'appareillage de commande a une fonction mécanique et électrique.

NOTE 2 Changer la vis qui retient l'appareillage de commande n'est pas considéré comme de la maintenance.

Pour les dispositifs d'arrêt de traction, des vis en matériau isolant qui appuient directement sur le câble ou le cordon peuvent être acceptées.

NOTE 3 Le remplacement de ces vis n'est pas considéré comme de la maintenance.

La conformité est vérifiée par examen, et les vis et écrous qui transmettent la pression de contact ou qui sont susceptibles d'être serrés par l'utilisateur doivent être serrés et desserrés cinq fois. Les vis et écrous en matériau isolant doivent être complètement enlevés, lors de chaque opération de desserrage des vis. Pendant l'essai, aucun dommage ne doit se produire, compromettant l'utilisation ultérieure de la fixation ou de la connexion vissée. Après l'essai, il doit encore être possible d'introduire la vis ou l'écrou en matériau isolant selon la manière prévue.

L'essai est effectué au moyen d'un tournevis ou d'une clé approprié(e), en appliquant un couple de torsion comme cela est spécifié dans le Tableau 5, sauf pour les vis en matériau isolant utilisées dans les ancrages de cordons et qui sont directement fixées sur le câble ou le cordon, pour lesquelles le couple de torsion est de 0,5 Nm.

Tableau 5 – Essais de couple sur les vis

Diamètre nominal extérieur du filetage des vis mm	Couple Nm		
	1	2	3
Jusqu'à 2,8 inclus	0,20	0,40	0,40
Au-dessus de 2,8 jusqu'à 3,0 inclus	0,25	0,50	0,50
Au-dessus de 3,0 jusqu'à 3,2 inclus	0,30	0,60	0,50
Au-dessus de 3,2 jusqu'à 3,6 inclus	0,40	0,80	0,60
Au-dessus de 3,6 jusqu'à 4,1 inclus	0,70	1,20	0,60
Au-dessus de 4,1 jusqu'à 4,7 inclus	0,80	1,80	0,90
Au-dessus de 4,7 jusqu'à 5,3 inclus	0,80	2,00	1,00
Au-dessus de 5,3 jusqu'à 6,0 inclus	–	2,50	1,25
Au-dessus de 6,0 jusqu'à 8,0 inclus	–	8,00	4,00
Au-dessus de 8,0 jusqu'à 10,0 inclus	–	17,00	8,50
Au-dessus de 10,0 jusqu'à 12,0 inclus	–	29,00	14,50
Au-dessus de 12,0 jusqu'à 14,0 inclus	–	48,00	24,00
Au-dessus de 14,0 jusqu'à 16,0 inclus	–	114,00	57,00

La forme de la lame du tournevis doit correspondre à la tête de la vis à soumettre à l'essai. Les vis ne doivent pas être serrées par saccades. Les dommages causés aux vasques sont négligés.

La colonne 1 du Tableau 5 s'applique aux vis métalliques sans tête qui, après serrage, ne dépassent pas du trou.

La colonne 2 s'applique:

- aux autres vis et écrous métalliques;
- aux vis en matériau isolant:
 - équipées d'une tête hexagonale dont les dimensions entre méplats dépassent le diamètre hors tout du filetage;
 - équipées d'une tête cylindrique avec cavité pour clé Alène, avec une dimension entre sommets diamétralement opposés dépassant le diamètre hors tout du filetage;
 - équipées d'une tête avec une fente, ou des fentes croisées, dont la longueur dépasse 1,5 fois le diamètre hors tout du filetage.

La colonne 3 s'applique aux autres vis en matériau isolant.

Les valeurs indiquées dans le Tableau 5 pour les vis de plus de 6,0 mm de diamètre s'appliquent aux vis en acier et analogues, utilisées surtout pour le montage du luminaire.

Les valeurs indiquées dans le Tableau 5 pour les vis de diamètre supérieur à 6,0 mm ne s'appliquent pas aux extrémités filetées des douilles, pour lesquelles les exigences sont spécifiées dans l'IEC 60238:2016, Article 16.

Les exigences du 7.12.1 ne s'appliquent pas aux écrous métalliques utilisés comme moyen de fixation pour les interrupteurs à bouton-poussoir.

7.12.2 Les vis qui transmettent une pression de contact et les vis qui sont manœuvrées lors du montage ou du raccordement du luminaire et qui ont un diamètre nominal inférieur à 3 mm doivent se visser dans une partie métallique.

Les vis ou écrous qui sont vissés au montage du luminaire ou au remplacement des lampes comprennent les vis ou écrous de fixation des vasques, couvercles, etc. Les raccordements de tubes filetés, les vis de fixation du luminaire sur sa surface de montage, les vis ou les écrous à serrage manuel pour la fixation des vasques en verre et les couvercles vissés sont exclus.

La conformité est vérifiée par examen et, pour les vis serrées au montage du luminaire ou au remplacement des lampes, par l'essai décrit en 7.12.1.

7.12.3 Les connexions vissées et autres assemblages fixes entre différentes parties de luminaires doivent être réalisés de sorte qu'ils ne puissent pas prendre de jeu sous l'effet de la torsion, des contraintes de flexion, vibrations, etc., qui peuvent se produire en usage normal. Les bras fixes et tubes de suspension doivent être fixés solidement.

NOTE Le desserrage des assemblages peut être prévenu par des moyens tels que, par exemple, la soudure, les écrous indéserrables et les vis de blocage.

La conformité est vérifiée par examen et en essayant de desserrer les connexions bloquées avec un couple de torsion ne dépassant pas:

- 2,5 Nm pour les filetages $\leq M 10$ ou diamètres correspondants;
- 5,0 Nm pour les filetages $> M 10$ ou diamètres correspondants.

Pour les douilles qui sont soumises à une action de rotation lors du remplacement de la lampe, la conformité doit être vérifiée par examen et en essayant de desserrer les connexions mécaniques vissées. L'essai n'est pas réalisé sur les douilles fixées aux luminaires par plus d'un moyen de fixation (par exemple deux vis de fixation). Le couple d'essai doit être appliqué pendant 1 min dans le sens et le sens opposé des aiguilles d'une montre avec un couple n'excédant pas:

- 4,0 Nm pour les douilles E40;
- 2,0 Nm pour les douilles E26, E27 et B22;
- 1,2 Nm pour les douilles E14 et B15 (excepté celles du type chandelier);
- 0,5 Nm pour les douilles E14 et B15 du type chandelier;
- 0,5 Nm pour les douilles E10.

Pour les autres douilles qui sont soumises à une action de rotation, un couple égal à deux fois le couple maximal de dévissage indiqué dans les exigences de douilles de l'IEC 60061-2 doit être appliqué pendant 1 min dans le sens et le sens opposé des aiguilles d'une montre, mais avec une valeur minimale de 1,2 Nm.

Pour les interrupteurs à bouton-poussoir, les moyens de fixation sont soumis à un couple de torsion ne dépassant pas 0,8 Nm.

Pendant l'essai, ces assemblages à vis ne doivent pas se dévisser.

7.12.4 Les presse-étoupes filetés doivent satisfaire à l'essai suivant.

Les presse-étoupes doivent être équipés d'une tige métallique cylindrique dont le diamètre est égal au nombre entier de millimètres immédiatement inférieur au diamètre intérieur de la garniture. Les presse-étoupes doivent alors être serrés au moyen d'une clé adaptée en appliquant sur la clé pendant 1 min le couple indiqué dans le Tableau 6.

Tableau 6 – Essais de torsion sur les presse-étoupes

Diamètre de la tige d'essai	Couple	
	Presse-étoupes métalliques	Presse-étoupes en plastique moulés
mm	Nm	Nm
Jusqu'à 7	4,00	2,5
Au-dessus de 7 jusqu'à 14	6,25	3,25
Au-dessus de 14 jusqu'à 20	7,50	5
Au-dessus de 20	10	7,50

Après l'essai, le luminaire et les presse-étoupes ne doivent présenter aucune détérioration.

7.13 Résistance mécanique

7.13.1 Les luminaires doivent avoir une résistance mécanique adéquate et être construits de manière à supporter en toute sécurité le maniement sans précautions qui peut être prévu en usage normal.

La conformité est vérifiée en appliquant des coups à l'échantillon au moyen de l'appareil d'essai de choc à ressort spécifié dans l'IEC 60068-2-75, ou par un autre moyen convenable donnant des résultats équivalents.

NOTE 1 Des énergies de choc équivalentes obtenues par des méthodes différentes ne donnent pas nécessairement le même résultat d'essai.

Le ressort du marteau doit être tel que le produit de la compression, en millimètres, et de la force exercée, en newtons, soit égal à 1 000, la compression étant d'approximativement 20 mm. Le ressort doit être réglable de manière à obtenir que le marteau frappe avec une énergie de choc et une compression du ressort comme cela est indiqué dans le Tableau 7.

Tableau 7 – Énergies de choc et compression du ressort

Niveau de choc	Énergies de choc J		Compression mm	
	Parties fragiles	Autres parties	Parties fragiles	Autres parties
Niveau 1 (faible énergie de choc): applicable aux luminaires qui sont normalement soumis à de faibles chocs mécaniques en raison de leur installation sur le mur ou le plafond ^a	0,2	0,35	13	17
Niveau 2 (énergie de choc moyenne): applicable aux luminaires pour lesquels une résistance mécanique plus élevée est exigée en raison de leur mobilité ou parce qu'ils sont facilement accessibles en utilisation normale ^b	0,35	0,50	17	20
Niveau 3 (énergie de choc élevée): applicable aux luminaires pour lesquels une résistance mécanique plus élevée est exigée en raison de leur installation sans protection supplémentaire ou parce qu'ils sont fréquemment manipulés ^c	0,5	0,70	20	24
Luminaires pour conditions sévères d'emploi, torches, luminaires encastrés dans le sol, luminaires à circulation d'air, guirlandes lumineuses, cordons lumineux, luminaires pour éclairage de sécurité et baladeuses pour utilisation dans les zones cliniques des hôpitaux (et établissements de soins de santé)	Autres méthodes d'essai spécifiées dans le présent document ou dans les parties spécifiques de la série IEC 60598-2.			
<p>Les douilles et autres composants ne sont resoumis à l'essai que dans la mesure où ils font saillie au-delà de l'encombrement du luminaire. La face avant des douilles n'est jamais resoumise à l'essai puisque, en fonctionnement normal, cette partie est recouverte par la lampe.</p> <p>Les parties fragiles sont les parties en verre et les vasques translucides qui ne procurent que la protection contre les poussières, les objets solides, l'humidité ou les UV. Les mécanismes de fixation ou de fermeture ne sont pas considérés comme étant des parties fragiles.</p> <p>Les écrans de protection exigés en vertu du 7.21 sont considérés comme des parties fragiles.</p> <p>^a Les luminaires exigeant une énergie de choc de Niveau 1 sont: luminaires encastrés, luminaires fixes d'usage général, luminaires portatifs pour montage en applique (pour utilisation à l'intérieur), et systèmes d'éclairage à très basse tension.</p> <p>^b Les luminaires exigeant une énergie de choc de Niveau 2 sont: lampadaires, luminaires portatifs à poser pour utilisation à l'intérieur, luminaires pour photo et cinéma et luminaires pour aquarium.</p> <p>^c Les luminaires exigeant une énergie de choc de Niveau 3 sont: projecteurs, luminaires pour l'éclairage des routes et des rues, luminaires pour piscines, luminaires portatifs destinés à être utilisés à l'extérieur, luminaires portatifs pour enfants, veilleuses montées sur des socles de prise de courant réseau et luminaires pour l'éclairage scénique, les studios de télévision et les studios cinématographiques (à l'extérieur et à l'intérieur).</p>				

NOTE 2 Le niveau des chocs a été décrit à des fins d'essais uniquement et n'est pas considéré comme une caractéristique assignée du produit.

Les vasques translucides, qui ne procurent ni la protection contre les chocs électriques ou les UV, ni la protection contre la poussière, les corps solides, l'humidité et les lampes, ne sont pas soumises à l'essai.

L'échantillon est monté ou fixé comme en usage normal sur une planche de bois rigide, les entrées de câbles étant laissées ouvertes, les entrées défonçables ouvertes, et les vis de fixation de la vasque et les vis similaires serrées avec un couple de torsion égal aux deux tiers des valeurs spécifiées dans le Tableau 5.

Trois chocs doivent être appliqués au point présumé le plus faible, en portant une attention spéciale aux matériaux isolants qui entourent des parties actives dangereuses et aux traversées isolantes, s'il y a lieu. Des échantillons supplémentaires peuvent être nécessaires pour déterminer le point le plus faible; en cas de doute, l'essai doit être répété sur un échantillon neuf auquel trois coups seulement sont appliqués.

Après l'essai, l'échantillon ne doit présenter aucune détérioration, en particulier:

- a) les parties actives dangereuses ne doivent pas être devenues accessibles;
- b) l'efficacité des recouvrements isolants et des cloisons isolantes ne doit pas avoir été compromise;
- c) l'échantillon doit continuer à procurer le degré de protection contre la pénétration des poussières, des corps solides et de l'humidité, conformément à sa classification;
- d) il doit être possible d'enlever et de remplacer les couvercles externes, sans briser ces éléments ni leurs recouvrements isolants.

Le bris d'une enveloppe est, cependant, admis si son enlèvement ne compromet pas la sécurité.

En cas de doute, une isolation supplémentaire ou renforcée est soumise à un essai de rigidité diélectrique comme cela est spécifié à l'Article 12.

L'endommagement de la finition, les petites bosses qui ne réduisent pas les lignes de fuite ou les distances dans l'air au-dessous des valeurs spécifiées à l'Article 13, ainsi que les petits écaillages qui n'ont pas d'influence défavorable sur la protection contre les chocs électriques, les poussières et l'humidité sont ignorés.

7.13.2 Les parties métalliques qui entourent les parties actives dangereuses doivent avoir une résistance mécanique convenable.

La conformité est vérifiée par les essais appropriés des 7.13.3 et 7.20.2.

7.13.3 Un doigt d'épreuve droit et sans articulation (calibre d'essai 11 selon l'IEC 61032:1997, Figure 7) est utilisé. Le doigt est appuyé contre la surface avec une force de 30 N.

Pendant l'essai, les parties métalliques ne doivent pas toucher de parties actives dangereuses.

Après l'essai, les vasques ne doivent pas présenter de déformations exagérées et le luminaire doit continuer de satisfaire aux exigences de l'Article 13.

7.13.4 Les appareillages de commande indépendants enfichables et les luminaires montés sur prises de courant réseau doivent avoir une résistance mécanique convenable.

La conformité est vérifiée par l'essai suivant, effectué dans un tambour qui tourne conformément à l'IEC 60068-2-31:2008, 5.3 (chutes libres répétées – méthode 2), selon les détails suivants:

Hauteur des chutes: 500 mm;

- 100 chutes si la masse de l'échantillon n'excède pas 100 g;
- 50 chutes si la masse de l'échantillon est supérieure à 100 g et inférieure ou égale à 250 g;
- 25 chutes si la masse de l'échantillon excède 250 g.

Les luminaires montés sur socles de prise de courant doivent être équipés de la source de lumière appropriée.

NOTE 1 Le nombre de chutes n'est pas celui pris en compte dans les critères de conformité de l'IEC 60068-2-31:2008.

Après l'essai, l'échantillon doit continuer de satisfaire aux exigences du présent document, mais il n'est pas nécessaire que l'échantillon soit fonctionnel et tout dommage subi par la source de lumière dans les luminaires montés sur prises de courant réseau doit être ignoré. À condition que la protection contre les chocs électriques ne soit pas compromise, les petits morceaux qui peuvent provenir de l'échantillon doivent être négligés.

La déformation des broches, l'endommagement de la finition et les petites bosses qui ne réduisent pas les lignes de fuite ou les distances dans l'air au-dessous des valeurs spécifiées à l'Article 13 doivent être ignorés.

NOTE 2 En Australie et en Nouvelle-Zélande, il existe des exigences spécifiques et différentes pour les appareillages de commande et les luminaires montés sur socles de prise de courant.

7.14 Suspensions, fixations et appareils de réglage

7.14.1 Les suspensions, y compris l'élément ou les éléments à aimant permanent, les fixations et les connexions mécaniques doivent présenter des facteurs convenables de sécurité.

Les aimants ne doivent pas être utilisés comme fixation principale d'un luminaire fixe sur la surface de montage.

NOTE 1 Si une plaque d'acier est fournie par un fabricant de luminaires comme partie intégrante du luminaire à fixer par des vis sur un mur ou un plafond, la plaque d'acier est considérée comme la fixation principale et non l'aimant permanent utilisé pour fixer le luminaire sur cette plaque d'acier.

La conformité est vérifiée par les essais appropriés parmi les suivants.

Essai A: Les fixations du luminaire à la surface de montage de l'installation et les fixations des autres parties externes supportées par le luminaire doivent être sûrement maintenues à leur place. L'essai suivant s'applique:

- *au luminaire suspendu, fixe ou monté sur rail (plafond – mur) – soumis à l'essai avec quatre fois le poids du luminaire complet en plus de son poids;*
- *aux parties externes fixées au luminaire (par exemple diffuseur, glace, réflecteur, paralume) – soumis à l'essai avec quatre fois le poids supporté, en plus de son poids. Il n'est pas nécessaire de soumettre à l'essai toutes les parties externes (par exemple les parties fixées à l'aide de plusieurs vis) si la conformité à l'exigence du 7.14.1 est évidente à partir des informations disponibles et par examen visuel.*

Une charge constante uniformément répartie et égale à quatre fois le poids du luminaire ou de la partie concernée doit être ajoutée à ce dernier dans la direction normale de la charge pendant 1 h. Il ne doit pas se produire de déformation significative des pièces qui composent le système de suspension et de fixation à la fin de cette durée. Lorsque plusieurs appareils de fixation ou de suspension sont fournis, chacun d'eux doit être soumis à l'essai séparément.

Essai B: Pour les luminaires à suspension rigide: Un couple de torsion de 2,5 Nm est appliqué aux luminaires pendant 1 min, d'abord dans le sens des aiguilles d'une montre puis en sens inverse. Pour cet essai, il ne doit pas être possible de faire tourner le luminaire de plus d'un tour dans chaque sens par rapport à la partie fixe.

Essai C: Pour les consoles à suspension rigide: Les détails de l'essai des consoles à suspension rigide sont les suivants.

- a) Pour les consoles à utilisation intensive (par exemple les consoles pour ateliers), une force de 40 N doit être appliquée pendant 1 min à l'extrémité libre, dans plusieurs directions, le bras de la console étant fixé comme en usage normal. Le moment de flexion résultant de cet essai ne doit pas être inférieur à 2,5 Nm. Lorsque la force d'essai est supprimée, le bras de la console ne doit pas avoir subi de déplacement ni de déformation permanent(e) susceptible de compromettre la sécurité.*
- b) Pour les consoles à faible utilisation (par exemple les consoles pour usage domestique), le même essai qu'au point a) doit être appliqué pendant 1 min, mais avec une force de 10 N, le moment de flexion résultant de cet essai ne devant pas être inférieur à 1,0 Nm.*

Essai D: Pour les luminaires montés sur rail: La masse du luminaire doit être mesurée et ne doit pas dépasser la valeur spécifiée pour les dispositifs de suspension du luminaire ou l'adaptateur de rail.

Essai E: Pour les luminaires à pince: Une traction est exercée sur le câble, sans secousse, pendant 1 min, dans la direction la plus défavorable en utilisation normale. Pendant l'essai, la pince est montée sur des "tablettes" d'essai normalisées en verre à vitre ordinaire, l'une ayant une épaisseur nominale de 10 mm, l'autre ayant l'épaisseur maximale sur laquelle la pince peut être montée. Pour cet essai, l'épaisseur de la tablette d'essai est augmentée par multiples de 10 mm. La pince ne doit pas tomber du verre, sous une force de traction de 20 N.

Les luminaires à pince doivent, en plus, être soumis à l'essai sur une tige métallique, de diamètre nominal de 20 mm, plaquée au chrome, et ayant une finition polie. Le luminaire ne doit pas tourner sous l'effet de son propre poids, et ne doit pas tomber de la tige, lorsqu'une force de traction de 20 N est appliquée sur le câble. L'essai sur une tige en métal poli n'est pas appliqué aux luminaires marqués: "Ne convient pas pour montage sur du matériel tubulaire".

NOTE 2 L'augmentation de l'épaisseur de la feuille d'essai, par palier de 10 mm jusqu'à l'épaisseur maximale, limite la possibilité de forcer la pince sur la tablette d'essai.

NOTE 3 Pour obtenir l'épaisseur maximale, la tablette d'essai peut comporter plusieurs couches de verre et de bois, à condition que les surfaces sur lesquelles la pince du luminaire est serrée soient en verre.

Lorsque des recommandations sont fournies ou que des moyens sont donnés par le fabricant pour assurer une installation et une utilisation sûres d'un luminaire fixe ou de l'appareillage de commande indépendant sans appareils de fixation (trous, consoles, etc.) (voir 6.4), cet équipement peut être considéré comme conforme aux exigences du présent document.

Le 7.14.1 ne vise pas à contrôler la résistance mécanique de la surface de montage de l'installation. Tout dommage de la surface de montage n'est pas un échec.

7.14.2 La masse du luminaire suspendu par des câbles ou cordons souples ne doit pas dépasser 5 kg par câble ou cordon souple. La section nominale totale des conducteurs des câbles ou cordons souples qui soutiennent des luminaires doit être telle que la contrainte imposée aux conducteurs ne dépasse pas 15 N/mm². Lorsque plus d'un câble ou cordon souple est utilisé, les instructions de montage doivent indiquer toutes les informations nécessaires afin d'éviter la surcharge de câble ou de cordon et d'assurer la répartition homogène de la charge.

Pour le calcul des contraintes, seuls les conducteurs sont pris en considération.

Lorsque la masse du luminaire suspendu par des câbles ou des cordons souples est supérieure à 5 kg par câble ou cordon souple, ou la charge maximale autorisée par les dimensions du conducteur, la conception du luminaire ou celle du câble ou du cordon souple doit être telle que l'application d'une tension quelconque aux conducteurs soit évitée.

EXEMPLE Un câble équipé d'un filin porteur incorporant des charges convenables.

Dans le cas d'un câble ou d'un cordon spécial avec un filin métallique supplémentaire ou des fibres non métalliques torsadées ensemble ou inclus dans la construction du câble, et lorsque les dimensions des conducteurs ne remplissent pas la contrainte maximale indiquée ci-dessus, il n'est pas possible d'empêcher une quelconque contrainte sur les conducteurs. La construction est jugée acceptable si le câble, y compris ses dispositifs de fixation des deux côtés, peut supporter un essai de traction appliqué pendant une période de 1 h avec une force de 15 fois la force normalement appliquée au câble en utilisation normale. Pendant l'essai, toutes les connexions électriques doivent être déconnectées.

Après l'essai, il ne doit y avoir:

- aucun bris du câble;
- aucune dégradation de l'isolation électrique en effectuant l'essai du 12.2.3;
- aucune déformation dangereuse des dispositifs de fixation.

La masse et le moment de flexion effectif des semi-luminaires prévus pour être raccordés aux douilles à vis Edison ou à baïonnette ne doivent pas excéder la valeur maximale donnée dans le Tableau 8. Le moment de flexion est relatif au point de contact dans la position complètement insérée du ou des contacts du semi-luminaire avec le contact central d'une douille à vis Edison ou les plongeurs d'une douille à baïonnette.

Tableau 8 – Essai des semi-luminaires

Douilles	Luminaires	
	Masse maximale	Moment de flexion maximal
E14 et B15	1,8 kg	0,9 Nm
E27 et B22	2,0 kg	1,8 Nm

NOTE Pour prévoir une marge de sécurité, ces valeurs sont inférieures à celles avec lesquelles devrait normalement être soumise à l'essai une douille.

La conformité est vérifiée par examen, par des mesurages, par des calculs ou par l'essai de traction du 7.14.2 ci-dessus.

7.14.3 Les exigences pour les appareils de réglage sont indiquées ci-dessous.

- a) Les appareils de réglage et les moyens de réglage, par exemple les raccords, les systèmes de hissage, les consoles réglables ou les tubes télescopiques, doivent être construits de manière à ne pas comprimer, serrer, endommager ou tordre les câbles ou cordons le long de l'axe longitudinal de plus de 360° lors du fonctionnement.

Si un luminaire a plus d'un raccord, la limite de 360° s'applique à chacun des raccords s'ils ne sont pas trop proches les uns des autres. Chaque cas doit être jugé d'après ses propres caractéristiques.

La conformité est vérifiée par examen et par l'essai suivant:

L'appareil de réglage, équipé du câble ou cordon approprié, doit être mis en fonctionnement conformément aux éléments du Tableau 9. Un cycle de fonctionnement est défini comme un mouvement d'une position extrême de la plage à l'autre et retour à la position de départ. La fréquence du mouvement ne doit pas entraîner d'échauffement significatif de l'appareil et ne doit pas dépasser 600 cycles par heure.

Pour les systèmes de contact électromécanique, le présent essai est effectué simultanément avec l'essai de connexion électrique du 7.11.6.

Pendant l'essai, les valeurs correspondant au Tableau 13 ne doivent pas être dépassées.

Après l'essai, pas plus de 50 % des brins d'un conducteur ne doivent être rompus et l'isolation du cordon souple, s'il en existe, ne doit pas être sérieusement endommagée. Le câble ou le cordon souple doit être soumis et doit satisfaire aux essais de résistance d'isolement et de rigidité diélectrique spécifiés en 12.2.

Les rotules et accessoires analogues, dont le dispositif de serrage peut être réglé, sont soumis à l'essai en les serrant légèrement pour éviter un excès de frottement. Si besoin est, les zones de serrage sont réglées de nouveau au cours de l'essai.

Pour les appareils de réglage qui consistent en un tube flexible, la plage de réglage, pour cet essai, est normalement de 135° dans les deux directions à partir de la verticale. Cependant, lorsque ce réglage ne peut être obtenu sans utilisation d'une force déraisonnable, le tube flexible n'est courbé que dans les positions où il peut se maintenir de lui-même.

- b) Les luminaires avec un moyen de réglage destinés à être installés dans un volume d'accessibilité au toucher doivent permettre le fonctionnement de leur fonction prévue sans altérer la stabilité du luminaire et sans causer de déformations sur une partie de la construction du luminaire ni causer de blessures en raison de températures supérieures à celles indiquées dans le Tableau 21.

La conformité est vérifiée en manipulant ou en manœuvrant le luminaire, au moyen du réglage prévu dans le cas d'une utilisation normale et par le mesurage de températures pendant l'essai du 14.4.

- c) Pour les luminaires destinés à être installés dans un volume d'accessibilité au toucher, l'espace environnant tout dispositif de réglage, à l'exception de l'ouverture du faisceau lumineux, doit respecter les limites de températures du dispositif de réglage selon le Tableau 21 à une distance jusqu'à 5 cm dans toutes les directions autour du dispositif de réglage. Les mêmes limites de température s'appliquent également à tous les dispositifs de réglage qui sont éclairés après positionnement de l'ouverture du faisceau lumineux.

La conformité est vérifiée en positionnant l'ouverture du faisceau lumineux du luminaire et en mesurant les températures pendant l'essai du 14.4.

Tableau 9 – Essai des appareils de réglage

Type de luminaire	Nombre de cycles de fonctionnement
Luminaires destinés à être réglés fréquemment, par exemple luminaires pour planche à dessin	1 500
Luminaires destinés à être réglés occasionnellement, par exemple spots de vitrines	150
Luminaires réglables	45

7.14.4 Les câbles ou cordons qui passent à travers des tubes télescopiques ne doivent pas être fixés au tube extérieur. Des dispositions doivent être prises pour éviter les contraintes sur les conducteurs au niveau des bornes.

La conformité est vérifiée par examen.

7.14.5 Les poulies de guidage pour cordons souples doivent être dimensionnées pour éviter toute détérioration des cordons par une courbure trop accentuée. Les rainures des poulies doivent être bien arrondies, le diamètre de la poulie au fond de la rainure étant au moins trois fois le diamètre du cordon. À l'exception des luminaires alimentés en TBTS ou TBTP, les poulies métalliques accessibles doivent être reliées à la terre de protection.

La conformité est vérifiée par examen.

7.14.6 Les appareillages de commande indépendants enfichables et les luminaires montés sur prises de courant réseau ne doivent pas exercer de contrainte indue sur les socles de prises de courant.

La conformité est vérifiée par l'essai suivant. L'appareillage de commande indépendant enfichable ou le luminaire monté sur prise de courant réseau est inséré, comme pour l'utilisation normale, dans un socle de prise de courant fixe, pivotant autour d'un axe horizontal passant par les lignes des centres des tubes de contact, à une distance de 8 mm derrière la face d'engagement du socle de prise de courant. Durant cet essai, l'appareillage de commande indépendant enfichable doit être équipé d'un câble de 1 m alimentant le luminaire en question ou d'un câble spécifié par le fabricant. Le câble doit être suspendu lors de l'essai.

Le couple additionnel appliqué au socle de prise de courant pour maintenir la face d'engagement dans le plan vertical ne doit pas excéder 0,25 Nm.

Pour les luminaires réglables et ajustables avec socles de prise de courant réseau, le couple de torsion totale transmis au socle pendant le réglage ne doit pas dépasser 0,5 Nm.

Le socle de prise de courant utilisé pour l'essai doit avoir le contact de terre (s'il existe) enlevé, à moins que le socle de prise de courant n'ait pour les broches des logements à volets qui s'ouvrent par insertion de la broche de terre.

7.15 Matériaux inflammables

7.15.1 Les vasques, abat-jour et parties analogues qui n'ont pas de fonction isolante et ne résistent pas à l'essai au fil incandescent à 650 °C du 15.3 doivent être suffisamment éloignés de toute partie chaude du luminaire (par exemple batteries, lampes, transformateurs) qui peut porter le matériau à sa température d'inflammation. Ces parties en matériau inflammable doivent comporter des fixations ou des appareils d'accrochage appropriés pour maintenir cette distance.

La distance par rapport aux parties chaudes mentionnées ci-dessus doit être d'au moins 30 mm, sauf dans le cas où le matériau est protégé par un écran placé à une distance d'au moins 3 mm des parties chaudes. Cet écran doit satisfaire à l'essai au brûleur-aiguille du 15.3.2 et ne doit comporter aucune ouverture; sa hauteur et sa longueur doivent être au moins égales aux dimensions correspondantes des parties chaudes. Il n'est pas exigé d'écran dans le cas où le luminaire comporte une cloison efficace à la chute des gouttes enflammées.

NOTE Les exigences du 7.15.1 sont représentées à la Figure 33.

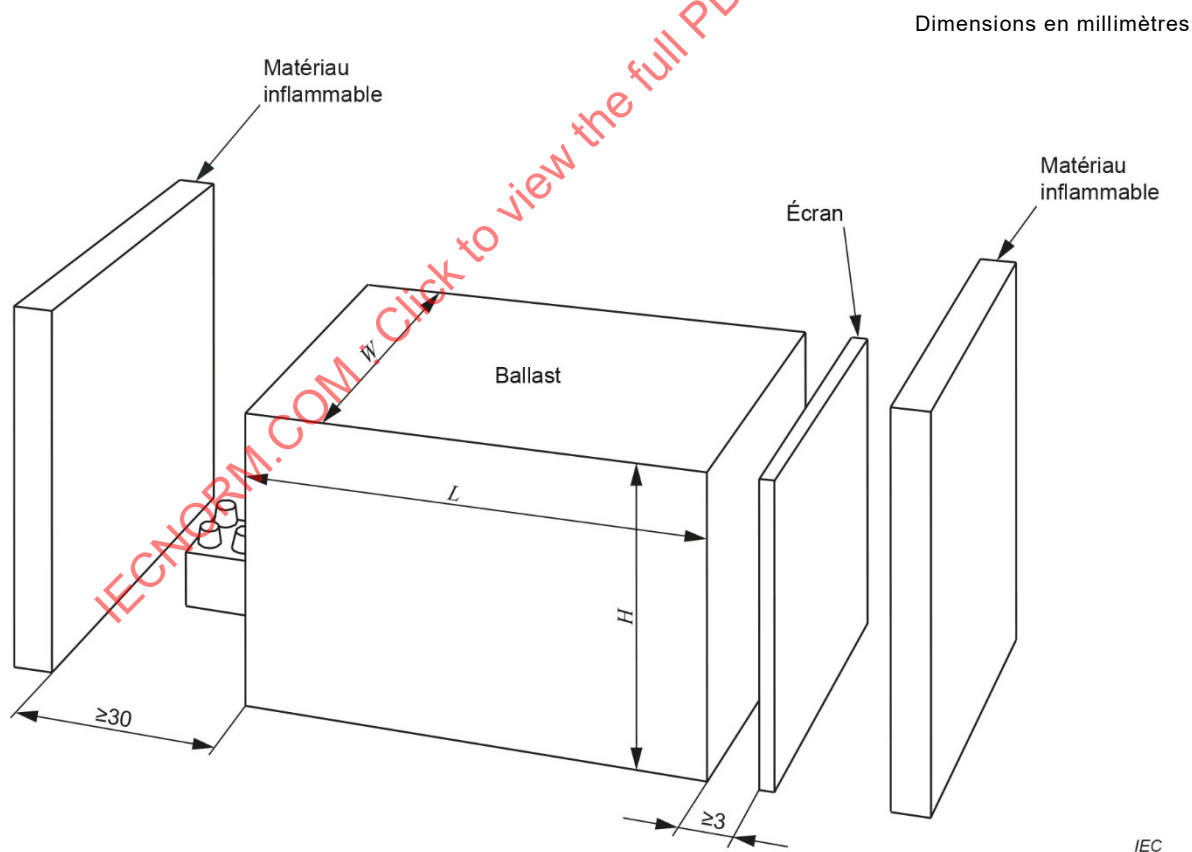

Figure 33 – Représentation des exigences du 7.15.1

Les matériaux qui brûlent violemment, comme le celluloïd, ne doivent pas être employés.

Les exigences du 7.15.1 ne s'appliquent pas aux petites pièces, tels les clips de câblages et les parties en papier imprégné de résine, employées à l'intérieur du luminaire.

Il n'est pas exigé de prévoir d'espacement par rapport aux circuits électroniques si le courant qui les traverse en fonctionnement anormal ne dépasse pas le courant de fonctionnement normal de plus de 10 %.

Il n'est pas exigé de prévoir d'espacement pour les parties du luminaire qui comportent un appareil de contrôle sensible à la température assurant la protection contre la surchauffe des vasques, des abat-jour ou parties analogues.

Les exigences du 7.15.1 ne s'appliquent pas à un transformateur équipé de sa propre enveloppe, c'est-à-dire IP20 ou supérieur, satisfaisant à la partie appropriée de la série IEC 61558.

La conformité est vérifiée par examen, par des mesurages et en faisant fonctionner le luminaire dans des conditions anormales et en élevant lentement et régulièrement le courant dans les enroulements du ballast ou du transformateur jusqu'à ce que l'appareil de contrôle sensible à la température fonctionne. Pendant et après cet essai, les vasques, les abat-jour et parties analogues ne doivent pas prendre feu et les parties accessibles ne doivent pas devenir des parties actives dangereuses.

Un essai selon l'Annexe A est exécuté afin de vérifier si les parties accessibles sont devenues des parties actives dangereuses.

7.15.2 Les luminaires en matériaux thermoplastiques doivent supporter des élévations de température, causées par des conditions défectueuses, dans les ballasts ou les transformateurs et les appareils électroniques, afin qu'aucun danger ne se produise lorsqu'ils sont montés comme en usage normal.

La présente exigence doit être respectée au moyen d'une des mesures suivantes.

- a) Mesures constructives assurant que:
- pendant les conditions de défaillances, les composants sont maintenus en place, par exemple par des supports mécaniques indépendants de la température;
 - des parties de luminaires ne peuvent pas être surchauffées de façon telle que des parties actives dangereuses puissent devenir accessibles.

La conformité est vérifiée par examen et par l'essai du 14.7.

- b) L'utilisation d'un appareil de contrôle sensible à la température, pour limiter la température des points de fixation du ballast ou du transformateur et de l'appareil électronique et des parties exposées du luminaire à une valeur sans danger. L'appareil de contrôle sensible à la température peut être soit un coupe-circuit thermique à réarmement manuel, soit un coupe-circuit thermique à réarmement automatique, soit un protecteur thermique.

La conformité est vérifiée par l'essai du 14.7.

- c) Les matériaux thermoplastiques utilisés dans les luminaires doivent être compatibles avec la température de surface maximale admise par l'utilisation d'appareillages de commande à protection thermique satisfaisant à la norme d'appareillage de commande correspondante.

La conformité est vérifiée par l'essai du 14.7.

7.16 Luminaires pour installation sur des surfaces normalement inflammables

7.16.1 Les luminaires classés comme pouvant être installés sur une surface normalement inflammable doivent satisfaire à l'une des exigences du 7.16.2, du 7.16.3 ou du 7.16.4.

NOTE 1 L'Annexe L donne des recommandations sur la façon d'utiliser les symboles et les avertissements.

Les exigences du 7.16 n'appliquent pas à un transformateur fourni avec sa propre enveloppe, c'est-à-dire IP20 ou supérieur, satisfaisant à la série IEC 61558. Pour les transformateurs pour rasoirs ou les unités d'alimentation de rasoirs incorporés dans un luminaire et satisfaisant à l'IEC 61558-2-5, les exigences du 7.16.2 s'appliquent. Les appareillages de commande électroniques pour les petits appareils bobinés qui peuvent être intégrés à ces composants sont dispensés des exigences du 7.16.

NOTE 2 Des exemples de petits appareils bobinés sont des enroulements ayant des noyaux de ferrite ou non feuilletés, ceux-ci étant normalement montés sur des cartes de circuit imprimé.

Pour les luminaires incorporant un appareillage de commande, la conformité à cette exigence doit être obtenue en écartant l'appareillage de commande de la surface de montage selon le 7.16.2 ou en utilisant la protection thermique selon le 7.16.3, ou en satisfaisant au 7.16.4.

Pour les luminaires qui ne contiennent pas d'appareillage de commande, les exigences sont respectées par la conformité à l'Article 14.

Du fait de leur application, les luminaires équipés d'un adaptateur pour montage sur rails doivent respecter les exigences relatives au montage direct sur les surfaces normalement inflammables.

7.16.2 L'appareillage de commande doit être écarté de la surface de montage d'une distance minimale de:

- a) 10 mm qui comprend l'épaisseur du matériau de l'enveloppe du luminaire, lorsque l'espace comprend un minimum de 3 mm d'air entre la surface extérieure de l'enveloppe du luminaire et la surface de montage de celui-ci dans la zone de l'appareillage de commande, et un minimum de 3 mm d'air entre le boîtier de l'appareillage de commande et la surface interne de l'enveloppe du luminaire. S'il n'y a pas de boîtier d'appareillage de commande, la distance de 10 mm doit s'appliquer à partir de la partie active, par exemple le conducteur ou les enroulements de l'appareillage de commande.

Il convient que l'enveloppe du luminaire soit continue dans la zone de projection de l'appareillage de commande de façon à éviter un cheminement direct de moins de 35 mm entre une partie active de l'appareillage de commande et la surface de montage, sinon les exigences du point b) s'appliquent;

ou

- b) 35 mm.

NOTE L'espace de 35 mm est destiné principalement à prendre en compte les luminaires à étrier de fixation pour lesquels la distance entre l'appareillage de commande et la surface de montage est souvent bien supérieure à 10 mm.

Dans les deux cas, le luminaire doit être conçu de telle manière que, lorsqu'il est monté comme pour l'utilisation normale, l'espace d'air nécessaire soit automatiquement obtenu.



La conformité est vérifiée par examen et par des mesurages.

7.16.3 Le luminaire doit comporter un appareil de contrôle sensible à la température pour limiter la température de la surface de montage du luminaire à une valeur sans danger. Cet appareil de contrôle sensible à la température peut être soit extérieur à l'appareillage de commande soit faire partie d'un appareillage de commande à protection thermique, conformément à la norme d'appareillage de commande correspondante.

L'appareil de contrôle sensible à la température peut être soit un coupe-circuit thermique à réarmement automatique, soit un coupe-circuit à réarmement manuel, soit un protecteur thermique (un coupe-circuit thermique qui ne fonctionne qu'une seule fois et qui exige d'être remplacé après utilisation).

Un dispositif de contrôle sensible à la température extérieur à l'appareillage de commande ne doit pas être du type "bouchon" ou d'un autre type facilement remplaçable. Il doit être maintenu dans une position fixe par rapport à l'appareillage de commande ou au transformateur.

La conformité est vérifiée par examen et par l'essai du 14.6.

Les exigences du 7.16.3 sont considérées comme respectées sans autre essai par les luminaires qui comportent un appareillage de commande ou un transformateur thermiquement protégé de "classe P" marqué du symbole  et par l'appareillage de commande ou le transformateur thermiquement protégé, à température déclarée, marqué du symbole  dans lequel est inscrite une valeur inférieure ou égale à 130 °C, conformément à la norme auxiliaire correspondante.

Les luminaires qui comportent un appareillage de commande ou un transformateur non marqué du symbole des appareillages de commande à protection thermique, ou qui porte une valeur marquée supérieure à 130 °C, doivent être conformes aux exigences du 7.16.2 ou du 7.16.4.

7.16.4 Si le luminaire n'est pas conforme aux exigences d'espacement du 7.16.2 et ne comporte pas de coupe-circuit thermique qui répond au 7.16.3, il doit être conçu de manière à satisfaire à l'essai du 14.6.

NOTE Cette exigence et son essai reposent sur la présomption que, durant la défaillance du ballast ou du transformateur, par exemple à la suite d'un court-circuit des enroulements ou à la mise en court-circuit du boîtier, la température de l'enroulement du ballast ou du transformateur ne dépasse pas 350 °C pendant une durée supérieure à 15 min et que, par conséquent, la température de la surface de montage n'excède pas 180 °C pendant une durée supérieure à 15 min.

7.17 Trous de vidange

Les luminaires protégés contre les gouttes d'eau, la pluie, les projections et les jets d'eau doivent être conçus afin que si l'eau s'y accumule, elle puisse être drainée efficacement, par exemple en créant un ou plusieurs trous de vidange. Les luminaires étanches à l'immersion ne doivent pas comporter de dispositifs de vidange.

La conformité est vérifiée par examen et par les essais de l'Article 11.

NOTE Un trou de vidange pratiqué au dos d'un luminaire pour pose en saillie est réputé efficace uniquement si la conception prévoit un espace d'au moins 5 mm par rapport à la surface de montage, par exemple au moyen d'entretoises au dos du luminaire.

7.18 Résistance à la corrosion

NOTE Comme les essais du 7.18 et de l'Annexe F peuvent être destructifs, ils peuvent être exécutés sur des échantillons séparés conformément au 4.2.2.

7.18.1 Les parties ferreuses des luminaires de classification IPX1 et supérieure, dont la rouille peut compromettre la sécurité du luminaire, doivent être convenablement protégées contre l'oxydation.

La conformité doit être vérifiée par l'essai suivant.

Enlever toute graisse des parties à soumettre à l'essai. Ensuite, immerger les parties dans une solution de chlorure d'ammonium à 10 % dans l'eau, à une température de 20 °C ± 5 °C pendant 10 min. Sans les sécher, mais en secouant les gouttes éventuelles, placer les parties dans une boîte contenant de l'air saturé d'humidité à une température de 20 °C ± 5 °C pendant 10 min.

Après avoir séché les parties dans une étuve à une température de 100 °C ± 5 °C pendant 10 min, leurs surfaces ne doivent présenter aucune trace d'oxydation. Ne sont pas prises en compte des traces d'oxydation sur les bords vifs ainsi que des films jaunâtres qui peuvent être enlevés par frottement.

Dans le cas de petits ressorts hélicoïdaux et d'éléments semblables, et des parties inaccessibles exposées à l'abrasion, une couche de graisse peut assurer une protection suffisante contre l'oxydation. De telles parties ne sont soumises à l'essai qu'en cas de doute en ce qui concerne l'efficacité du film de graisse, l'essai étant effectué sans enlèvement préalable de la graisse.

7.18.2 Les contacts et autres parties en feuilles laminées de cuivre ou d'alliages de cuivre, dont la défaillance peut compromettre la sécurité du luminaire, doivent être sans corrosion sous tension.

La conformité est vérifiée par l'essai de l'Annexe F, qui doit être réalisé sur des échantillons non soumis à d'autres essais.

7.18.3 Les parties en aluminium ou en alliages d'aluminium des luminaires protégés contre les gouttes d'eau, la pluie, les projections et les jets d'eau et celles des luminaires étanches à l'immersion et à l'immersion sous pression, doivent être résistantes à la corrosion, si la sécurité du luminaire peut autrement être compromise.

NOTE Des recommandations relatives à la résistance à la corrosion sont données à l'Annexe J.

7.19 Amorceurs

Les amorceurs utilisés dans les luminaires doivent être électriquement compatibles avec les ballasts qui leur sont associés dans le luminaire.

La conformité est vérifiée par examen.

7.20 Luminaires pour conditions sévères d'emploi

7.20.1 Les luminaires pour conditions sévères d'emploi doivent avoir une résistance adéquate aux vibrations.

La conformité est vérifiée au moyen de l'essai de vibration suivant, comme cela est spécifié dans l'IEC 60068-2-6.

Le luminaire est fixé à un générateur de vibrations, dans la position d'installation normale la plus défavorable.

La direction de la vibration est la direction la plus défavorable, les paramètres de réglage étant:

<i>durée:</i>	<i>30 min;</i>
<i>amplitude:</i>	<i>0,35 mm;</i>
<i>plage de fréquences:</i>	<i>10 Hz, 55 Hz, 10 Hz;</i>
<i>vitesse de balayage:</i>	<i>approximativement une octave par minute.</i>

Après l'essai, le luminaire ne doit avoir aucune pièce desserrée qui puisse compromettre la sécurité.

7.20.2 Les luminaires pour conditions sévères d'emploi doivent avoir une protection contre la pénétration de corps solides et d'humidité d'au moins IP54.

La conformité est vérifiée par examen et par l'essai approprié du 11.2.

Le luminaire pour conditions sévères d'emploi doit avoir une résistance mécanique adéquate et ne doit pas se renverser dans les situations qui peuvent être prévues en usage normal. De plus, les moyens de fixation du support auxquels le luminaire est connecté doivent avoir une résistance mécanique adéquate.

La conformité est vérifiée par les essais de a) à d) ci-dessous.

a) *Luminaires fixes et portatifs pour conditions sévères d'emploi (baladeuses exceptées)*

Chacun des trois échantillons de luminaires doit être soumis à trois chocs simples appliqués aux points présumés les plus faibles sur une surface normalement exposée. L'échantillon, sans lampe (ou lampes), est monté comme en usage normal sur une surface d'appui rigide.

Les chocs sont produits comme cela est représenté à la Figure 34, en laissant tomber d'une hauteur H (1,3 m) une bille d'acier de 50 mm de diamètre, pesant 0,51 kg, afin de produire une énergie de choc de 6,5 Nm.

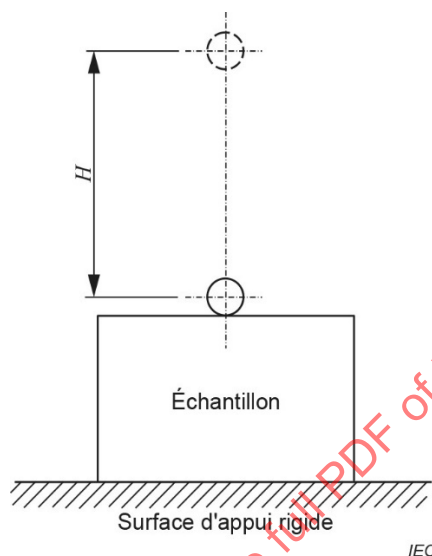

IEC

Il convient que la surface d'appui rigide soit placée verticalement pour un essai de choc latéral.

Figure 34 – Appareil pour les essais de choc à la bille

Chacun des trois échantillons de luminaire prévus pour utilisation à l'extérieur doit, de plus, être refroidi à une température de $-5\text{ °C} \pm 2\text{ °C}$ et maintenu pendant 3 h à cette température.

Pendant que les échantillons sont à cette température, ils doivent être soumis à l'essai de choc spécifié ci-dessus.

b) *Baladeuses*

Le luminaire est laissé tomber quatre fois d'une hauteur de 1 m sur une surface d'appui rigide. Les chutes s'effectuent chaque fois à partir de quatre positions initiales horizontales différentes, le luminaire étant tourné de 90° autour de son axe entre chaque chute. Pour cet essai, les lampes sont enlevées, mais les glaces protectrices, si elles existent, ne le sont pas.

NOTE Un sol en béton est un exemple de surface d'appui rigide.

Après l'essai du 7.20.2 a) ou 7.20.2 b), le luminaire ne doit présenter aucune détérioration préjudiciable à sa sécurité ou à son utilisation ultérieure. Les parties qui protègent la lampe contre les détériorations ne doivent pas s'être desserrées. L'endommagement de la finition, la déformation et les bosses qui ne compromettent pas la sécurité sont ignorés. Le bris d'une glace de protection ou d'une vasque translucide n'est pas pris en considération si la glace ou la vasque ne sont pas les seuls moyens de protection de la lampe contre les détériorations.

c) *Luminaires livrés avec support*

Toute lampe est enlevée avant les essais.

Le luminaire et le support ne doivent pas se renverser lorsqu'ils sont penchés d'un angle de 6° par rapport à la verticale.

Le luminaire doit supporter les chocs résultant de quatre renversements à partir d'un angle de 15° au maximum par rapport à la verticale.

Les moyens de fixation du support doivent supporter, dans la direction la plus défavorable, une force égale à quatre fois le poids du luminaire.

Si le luminaire se retourne pendant l'essai sur le plan incliné à un angle de 15° par rapport à la verticale, l'essai du 14.5 est réalisé avec le luminaire qui repose sur une surface horizontale, dans la plus défavorable des positions retournées qui peuvent raisonnablement se produire dans la pratique.

d) *Luminaires pour installations provisoires et adaptés au montage sur support*

Le luminaire doit supporter quatre chocs résultant de l'essai ci-après.

Toute lampe est enlevée avant l'essai.

Le luminaire est suspendu par une tige d'aluminium, le long d'un mur en béton ou en brique. La longueur de la tige est celle du support, comme cela est indiqué dans les instructions de montage en ce qui concerne l'utilisation d'un support.

Le luminaire est levé jusqu'à ce que la tige soit dans le plan horizontal, puis est laissé tomber librement contre le mur.

Après l'essai, la sécurité ne doit pas être compromise.

7.21 Écran de protection

7.21.1 En raison d'un risque potentiel d'explosion de la lampe, les luminaires conçus pour des lampes tungstène-halogène et les luminaires conçus pour des lampes aux halogénures métalliques doivent être équipés d'un écran de protection. Pour les lampes tungstène-halogène, l'écran doit être en verre.

Les luminaires conçus pour être utilisés uniquement avec des lampes autoprotégées sont dispensés de cette exigence, cependant ils doivent être marqués avec le symbole approprié.

NOTE 1 Les lampes qui exigent un écran de protection comme partie de la construction du luminaire sont fournies avec une notice d'avertissement appropriée ou leur emballage est marqué avec le symbole ci-après:



[SOURCE: IEC 60417-6071:2011-09 – Attention, lampe non protégée]

NOTE 2 Pour les lampes qui n'exigent pas un écran de protection comme partie de la construction du luminaire (lampes autoprotégées), leur emballage est marqué avec le symbole ci-après:

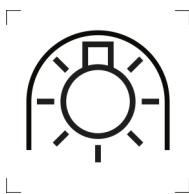

[SOURCE: IEC 60417-6030:2009-11 – Lampe autoprotégée, général]

7.21.2 Les parties du compartiment lampe doivent être conçues de telle manière qu'aucune particule d'une lampe brisée ne puisse compromettre la sécurité.

7.21.3 Toutes les ouvertures dans le luminaire doivent être telles qu'aucune partie d'une lampe brisée ne puisse quitter le luminaire, par cheminement direct (vision directe), y compris l'arrière des luminaires encastrés.

7.21.4 La conformité aux 7.21.1 à 7.21.3 est vérifiée par examen et par les essais suivants:

- l'écran de protection doit satisfaire à l'essai de choc du 7.13.1 avec l'énergie de choc du Tableau 7 pour les parties fragiles. Dans le cas où le dispositif de montage d'écran de verre est uniquement conçu pour résister aux chocs de l'intérieur, il convient si possible que l'essai du 7.13.1 soit réalisé dans cette direction;
- les parties du compartiment lampe, si elles sont en matériau isolant, doivent satisfaire à l'essai de résistance à la flamme et à l'inflammation du 15.3.

NOTE 1 Ces exigences visent à améliorer la sécurité, en éliminant les dangers dus à une possible lampe défectueuse ou à une utilisation incorrecte. Les luminaires ouverts existants, non équipés d'un écran de protection, ne présentent pas forcément un danger.

NOTE 2 L'essai de choc du 7.13.1, qui est réalisé de l'extérieur, est considéré comme plus sévère que les chocs des particules de verre. Un essai spécifique qui simule ces derniers n'est par conséquent pas nécessaire.

7.22 Accessoires fixés aux lampes

Les luminaires ne doivent pas comporter d'accessoires fixés aux lampes qui peuvent provoquer une surchauffe excessive ou endommager les lampes, culots ou douilles, les luminaires ou les accessoires.

Les accessoires pour lampes fluorescentes ne sont autorisés que s'ils sont fournis ou approuvés par le fabricant de luminaires. Le poids total de la lampe plus l'accessoire ne doit pas excéder:

- 200 g pour les lampes avec culots G5, et
- 500 g pour les lampes avec culots G13.

La conformité est vérifiée par examen, par des mesurages de poids et de température, si approprié.

NOTE Des accessoires fixés aux lampes à incandescence qui sont susceptibles de ne pas satisfaire à ces exigences sont, par exemple, les réflecteurs à calotte argentée, les réflecteurs autour des lampes. Des accessoires qui peuvent être admis sont, par exemple, des ressorts pour abat-jour légers pour lampes et appareils similaires.

7.23 Semi-luminaires

Les semi-luminaires doivent satisfaire à toutes les exigences correspondantes des luminaires de classe II.

NOTE Le symbole de la classe II est omis pour éviter qu'il ne soit considéré comme s'appliquant au luminaire complet dans lequel le semi-luminaire est utilisé.

7.24 Dangers photobiologiques

7.24.1 Dangers actiniques des UV pour la peau et l'œil (200 nm à 400 nm)

Les luminaires ne doivent pas émettre de rayonnement UV excessif lorsqu'ils sont utilisés avec des sources de lumière.

La conformité est vérifiée par l'évaluation du luminaire conformément à l'IEC 62471-7:2023, 5.3.

Les luminaires conçus pour être utilisés avec des lampes autoprotégées uniquement ou les luminaires avec des sources de lumière de limite d'émission UV $\leq 2 \text{ mW} \cdot \text{klm}^{-1}$ sont conformes à l'IEC 62471-7:2023, 5.3.

Les luminaires avec des sources de lumière d'émission $\leq 6 \text{ mW} \cdot \text{klm}^{-1}$ et équipés d'une vasque en verre qui couvre toutes les sources de lumière sont conformes à l'IEC 62471-7:2023, 5.3.

NOTE 1 Voir l'IEC 60432-3 et l'IEC 62035 pour le marquage des lampes.

Pour les luminaires avec des sources de lumière d'émission $> 6 \text{ mW} \cdot \text{klm}^{-1}$, l'Annexe M décrit les méthodes pour fournir un écran adéquat pour les rayonnements UV.

NOTE 2 Voir l'Annexe M, procédure A ou procédure B pour les méthodes de calcul qui visent à fournir un écran efficace contre le rayonnement UV.

7.24.2 Danger des UV-A pour le cristallin de l'œil (315 nm à 400 nm)

Les luminaires ne doivent pas émettre de rayonnement UV-A excessif lorsqu'ils sont utilisés avec des sources de lumière.

La conformité est vérifiée par l'évaluation du luminaire conformément à l'IEC 62471-7:2023, Article 6.

NOTE Conformément à l'IEC 62471-7:2023, 6.2, la limite d'exposition aux UV-A n'est pas dépassée dans les luminaires et aucun essai n'est nécessaire si des UV-A ne sont pas volontairement ajoutés à la lumière visible.

7.24.3 Danger rétinien lié à la lumière bleue

7.24.3.1 Généralités

Les luminaires doivent satisfaire aux exigences du 7.24.3.2 (évaluation selon l'IEC 62471-7) ou du 7.24.3.3 (évaluation selon l'IEC TR 62778).

NOTE Il est prévu que la prochaine édition du présent document supprime le 7.24.3.3, car l'IEC 62471-7 remplace complètement l'IEC TR 62778. Dans l'intervalle, le 7.24.3.2 ou le 7.24.3.3 peut être utilisé.

7.24.3.2 Évaluation du luminaire selon l'IEC 62471-7:2023

Les luminaires avec sources de lumière pour lesquelles la norme de sécurité de la source de lumière n'exclut pas la source de lumière du danger rétinien lié à la lumière bleue doivent être évalués conformément à l'IEC 62471-7:2023, 7.3.

NOTE 1 Actuellement, les seuls types de sources de lumière pour lesquels il est important de prendre en compte le danger lié à la lumière bleue sont: les types à LED, à halogénures métalliques et certains types tungstène-halogène spécialisés.

Les luminaires ne doivent pas dépasser les limites d'émission de la luminance énergétique de la lumière bleue aux distances d'évaluation des luminaires conformément à l'IEC 62471-7:2023, Tableau 2.

Pour les luminaires fixes, la distance d'évaluation conformément à l'IEC 62471-7:2023, Tableau 2, peut être augmentée si cela est approprié pour l'application du luminaire spécifique. Dans ce cas, les informations relatives à la distance d'évaluation utilisée x en mètres doivent être fournies conformément au 6.3.22 a) du présent document. Si le luminaire satisfait aux exigences de l'IEC 62471-7:2023, Tableau 2, aucun marquage supplémentaire n'est exigé.

Selon l'IEC 62471-7:2023, les données de la source de lumière relatives au danger lié à la lumière bleue peuvent être transférées au luminaire sans essai supplémentaire sur le luminaire, à condition que la source de lumière ait été classée dans un groupe d'application conformément à la procédure de l'IEC 62471-7:2023, 7.2. Si aucune évaluation de la source de lumière conformément à l'IEC 62471-7:2023, 7.2 n'est disponible, le luminaire complet doit être évalué.

7.24.3.3 Évaluation du luminaire selon l'IEC TR 62778:2014⁴

Les luminaires avec sources de lumière pour lesquelles la norme de sécurité n'exclue pas la source de lumière du danger rétinien lié à la lumière bleue doivent être évalués conformément à l'IEC TR 62778.

Les sources de lumière avec un degré de groupe de risque lié à la lumière bleue supérieur à RG2 nécessitent des exigences de protection plus défavorables pour gérer le danger lié à la lumière bleue.

NOTE 1 Actuellement, les seuls types de sources de lumière pour lesquels il est important de prendre en compte le danger lié à la lumière bleue sont: les types à LED, à halogénures métalliques et certains types tungstène-halogène spécialisés.

NOTE 2 Les exigences pour les luminaires qui utilisent des sources de lumière RG3 ne sont pas encore établies, car ces produits ne sont généralement pas disponibles sur le marché. D'autres exigences seront établies à l'avenir, en cas de besoin.

Pour les luminaires qui utilisent des sources de lumière ayant au plus un degré RG1 illimité conformément à l'IEC TR 62778, et pour les luminaires complètement assemblés pour utilisation qui ont été évalués comme ne dépassant pas RG1, dans les mêmes conditions, aucune exigence concernant le danger rétinien lié à la lumière bleue ne s'applique.

Pour les luminaires ayant un seuil de l'éclairement lumineux E_{thr} évalué conformément à l'IEC TR 62778, les exigences suivantes s'appliquent:

- a) pour les luminaires fixes, une évaluation supplémentaire conformément à l'IEC TR 62778 doit être effectuée afin de trouver la distance x m entre le luminaire et la limite entre RG2 et RG1. Le luminaire doit être marqué et accompagné d'instructions conformément au 6.3.22 du présent document; Les données photométriques indiquées par les fabricants pour le luminaire peuvent être utilisées comme base pour l'évaluation;
- b) les luminaires portatifs et les baladeuses qui dépassent RG1 à 200 mm évalués conformément à l'IEC TR 62778 doivent être marqués conformément au 6.3.22 du présent document.

NOTE 3 Le cas échéant, l'information sur le danger lié à la lumière bleue est fournie pour la source de lumière selon les exigences de la norme de sécurité de la source de lumière.

NOTE 4 Dans certaines conceptions de luminaires, par exemple les luminaires avec sources de lumière intégrées, il peut s'avérer nécessaire de soumettre à l'essai le luminaire complet.

Les luminaires portatifs pour enfants, traités par l'IEC 60598-2-10, et les veilleuses montées sur des socles de prise de courant réseau, traitées par l'IEC 60598-2-12, ne doivent pas dépasser RG1 à 200 mm, conformément à l'IEC TR 62778.

NOTE 5 De futurs amendements spécifiques à l'IEC 60598-2-10 et à l'IEC 60598-2-12 suivront à cet égard.

7.24.4 Danger thermique pour la rétine (380 nm à 1 400 nm)

Les luminaires avec sources de lumière pour lesquelles la norme de sécurité de la source de lumière n'exclut pas le danger thermique pour la rétine doivent être évalués conformément à l'IEC 62471-7:2023, Article 8.

NOTE Avec la technologie actuelle, seules les lampes à arc (lampes à décharge à haute intensité au xénon ou au mercure), les sources de lumière à LED à courant élevé ou les sources de lumière à laser sont susceptibles de dépasser la limite L_R de $280\,000\text{ W} \cdot \text{m}^{-2} \cdot \text{sr}^{-1}$.

⁴ Supprimé.

Le danger thermique pour la rétine ne doit être pris en compte que pour les sources de lumière blanche dont la luminance énergétique relative au danger lié à la lumière bleue L_B est supérieure à $100\,000\text{ W} \cdot \text{m}^{-2} \cdot \text{sr}^{-1}$.

Les luminaires ne doivent pas dépasser les limites de luminance énergétique thermique pour la rétine données dans l'IEC 62471-7:2023.

7.24.5 Danger des infrarouges pour l'œil (780 nm à 3 000 nm)

Les luminaires avec sources de lumière pour lesquelles la norme de sécurité de la source de lumière n'exclut pas l'évaluation du danger des infrarouges pour l'œil doivent être évalués conformément à l'IEC 62471-7:2023, Article 9.

Les sources de lumière ne présentent pas un rayonnement E_{IR} suffisant pour dépasser la limite dans l'application. Seules les applications dans lesquelles un rayonnement IR est intentionnellement ajouté à la lumière visible doivent être évaluées.

7.24.6 Danger thermique pour la peau (380 nm à 3 000 nm)

Conformément à l'IEC 62471-7:2023, Article 10, la limite d'exposition n'est pas dépassée et aucun essai n'est nécessaire.

7.25 Dangers mécaniques

Les luminaires ne doivent pas comporter de parties ou des bords tranchants qui peuvent, lors de l'installation, l'usage normal ou l'entretien, créer un danger pour l'utilisateur.

La conformité est vérifiée par examen.

7.26 Protection contre les courts-circuits

7.26.1 Des moyens de protection doivent être fournis afin d'éviter de compromettre la sécurité, dans le cas d'un court-circuit non intentionnel, de parties accessibles TBTS ou TBTP non isolées, de polarité opposée. Les luminaires de classe III, alimentés à partir d'une alimentation TBTS ou TBTP séparée non définie, peuvent comporter un conducteur isolé. Lorsque l'isolation n'est pas prévue, le fabricant du luminaire peut déclarer la puissance maximale en VA et le type de source TBTS ou TBTP et l'essai du 7.26.1 peut être réalisé avec le transformateur ou convertisseur concerné.

La conformité est vérifiée par l'essai suivant.

Un échantillon d'essai de type est alimenté de 0,9 à 1,1 fois sa tension assignée, avec sa charge nominale. Lorsque la source d'alimentation est un PSE ES1, aucun essai de court-circuit n'est exigé. Une chaîne d'essai positionnée comme cela est spécifié en 7.26.2 est suspendue par-dessus les parties accessibles en TBTS ou TBTP et non isolées. La chaîne d'essai doit former le chemin le plus court possible en étant chargée à chaque extrémité (au maximum avec 250 g), avec un poids égal à:

$$m = a \times n$$

où

m est la masse de charge de la chaîne d'essai en grammes (g);

a est le facteur empirique 15;

n est la distance en cm entre les conducteurs à l'état non chargé.

La chaîne d'essai ne doit pas fondre, et aucune partie de l'échantillon d'essai de type ne doit atteindre une température supérieure aux valeurs du Tableau 21 et du Tableau 22.

7.26.2 La chaîne d'essai est une chaîne de longueur suffisante en métal non recouvert, qui comporte des maillons selon la Figure 35 et réalisée avec 63 % Cu et 37 % Zn. La chaîne doit avoir une valeur de résistance de $2,5 \Omega/m$ avec une tolérance de $\pm 20 \%$ lorsqu'elle est tendue avec une charge de 200 g/m . Il convient de vérifier la valeur de la résistance de la chaîne d'essai avant chaque mesurage.

Dimensions en millimètres

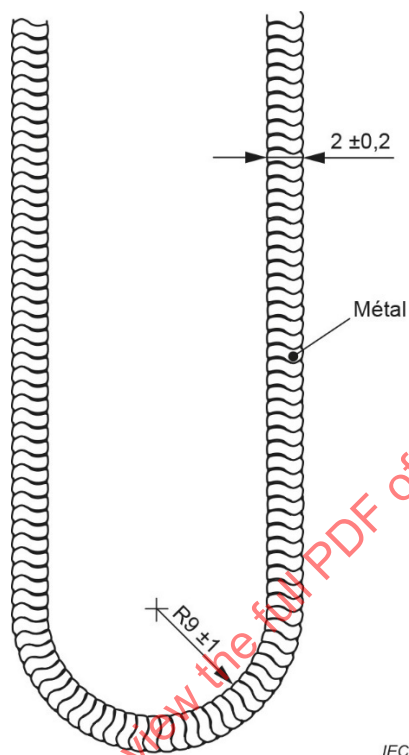

Figure 35 – Chaîne d'essai

7.27 Bloc de jonction avec contacts automatiques de terre de protection intégrés

Les blocs de jonction avec contacts automatiques de terre de protection intégrés doivent être montés conformément aux exigences indiquées par le fabricant en faisant référence à l'Annexe R.

La conformité est vérifiée par examen.

7.28 Fixation des appareils de contrôle sensibles à la température

Aucun dispositif de contrôle sensible à la température extérieur à l'appareillage de commande ne doit être du type "bouchon" ou d'un autre type facilement remplaçable. Il doit être conservé de manière fiable dans sa position spécifiée par rapport à l'appareillage de commande.

La fixation adhésive d'appareils de contrôle sensibles à la température ne doit pas être utilisée lorsque le rayonnement UV émis par une source de lumière peut altérer la fiabilité de la fixation pendant la durée de vie du luminaire. Les appareils de contrôle sensibles à la température ne doivent pas être installés à l'extérieur de l'enveloppe du luminaire.

La conformité est vérifiée par examen, et pour les appareils de contrôle sensibles à la température avec une fixation adhésive, selon l'essai suivant.

L'appareil de contrôle sensible à la température, avec l'appareillage ou le transformateur auquel il est fixé, est soumis à l'essai de variation de la température conformément à l'IEC 60068-2-14:2023, essai Na, selon les détails suivants.

L'éprouvette doit être soumise à 100 cycles entre les valeurs minimale et maximale stipulées ci-dessous.

La température maximale est celle mesurée sur le matériau adhésif lorsque l'appareillage de commande ou le transformateur est chargé d'un courant égal à 0,95 fois la valeur du courant le plus bas forçant l'appareil de protection à fonctionner dans des conditions stables.

La température d'essai minimale est 0 °C.

La durée d'exposition à chacune des températures est de 30 min chacune.

Comme cela est spécifié dans l'IEC 60068-2-14:2023, la durée de transition normale est comprise entre 2 min et 3 min. Une durée de transition (t_2) inférieure à 30 s est admise si un système d'essai automatique est utilisé.

Durant l'essai, l'appareil de contrôle sensible à la température ne doit pas subir de changement de fixation altérant son utilisation ultérieure, surtout par rapport à sa température de fonctionnement. Après l'essai, l'appareil de contrôle sensible à la température ne doit pas être détaché ou s'être déplacé de sa position prévue.

Les transformateurs qui satisfont à la série IEC 61558 ne sont pas soumis à cet essai.

7.29 Luminaires avec sources de lumière non remplaçables

Il ne doit pas être possible de remplacer les sources de lumière ou d'accéder aux parties actives dangereuses sans casser le luminaire ou ses parties.

La conformité est vérifiée par l'essai suivant.

Les parties du luminaire permettant d'accéder à la source de lumière qui peuvent être ouvertes à la main ou à l'aide d'un outil doivent être ouvertes ou enlevées.

Les parties du luminaire scellées ou collées à la glue, ou fixées à l'aide de vis qui sont conçues pour n'être utilisées qu'une seule fois, ou les cloisons encastrées de façon permanente ne sont pas ouvertes.

Après avoir retiré toutes les parties comme cela est stipulé ci-dessus, il ne doit pas être possible d'accéder aux parties actives dangereuses comme cela est vérifié avec le calibre d'essai et la méthode d'essai conformes à l'Article 10.

7.30 Luminaires avec sources de lumière non remplaçables par l'utilisateur et composants non remplaçables par l'utilisateur final

Lorsqu'une vasque de protection est utilisée par-dessus une source de lumière non remplaçable par l'utilisateur ou un composant non remplaçable par l'utilisateur final pour fournir une protection contre les chocs électriques, et que la vasque est marquée avec le symbole "danger, risque de chocs électriques" décrit en 6.3.23, la vasque doit rester en place durant les essais et les contrôles décrits à l'Article 9 et à l'Article 10. La vasque doit être maintenue en position tout en sécurité par au moins un moyen de fixation, chacun exigeant l'utilisation d'un outil pour son retrait.

7.31 Isolation entre les circuits

7.31.1 Généralités

Les luminaires qui comportent des transformateurs ou des appareillages de commande fournissant une isolation entre les circuits et les luminaires utilisant les circuits isolés du réseau d'alimentation doivent fournir une isolation adaptée entre les circuits et entre ces circuits et les parties conductrices externes accessibles.

Les mêmes exigences s'appliquent aux circuits connectés aux bornes de contrôle d'un luminaire contrôlable lorsque le même niveau d'isolation doit être conservé pour tous les composants. Lors de l'évaluation du type de circuit concerné, les informations données par le fabricant de l'appareillage de commande (voir l'IEC 61347-1:2015, 7.1 k) doivent être pris en compte.

NOTE Actuellement, sur le marché, les types de systèmes de commande suivants sont disponibles:

- signal de commande TBTF, avec isolation principale par rapport au réseau d'alimentation (par exemple, interface d'éclairage adressable numérique et commande CC 1–10 V);
- signal de commande TBTS/TBTP, (par exemple DMX);
- signal de commande non isolé du réseau d'alimentation (par exemple, commande par bouton-poussoir, découpage de phase, réduction par échelons).

La conformité est vérifiée au moyen des exigences suivantes.

7.31.2 Circuits TBTS ou TBTP

Les sources suivantes peuvent être utilisées pour alimenter les circuits TBTS ou TBTP:

- un transformateur d'isolation de sécurité conforme à l'IEC 61558-2-6 ou à la partie équivalente de la série IEC 61558-2;
- un appareillage de commande qui fournit TBTS ou TBTP conformément à la série IEC 61347;
- une source électrochimique (par exemple une batterie) ou une autre source indépendante d'un circuit à tension plus élevée;
- un PSE qui fournit un courant ES1 conformément à l'IEC 62368-1, satisfaisant aux exigences de l'IEC 62368-3.

NOTE En utilisant des connecteurs conformes à la série IEC 62680 ou à la série IEC 60603, le système satisfait par défaut aux exigences d'une TBTS.

Le circuit TBTP doit avoir un pôle relié à la terre pour des raisons fonctionnelles. La mise à la terre fonctionnelle du circuit TBTP peut être connectée au circuit de terre de protection. Jusqu'au point où le circuit TBTP est connecté à la terre de protection ou au conducteur de terre de protection, la connexion de mise à la terre du circuit TBTP doit satisfaire à l'exigence relative à mise à la terre fonctionnelle.

La tension dans les circuits ne doit pas être supérieure aux limites définies pour la TBT.

Les circuits TBTS ou TBTP doivent être isolés du réseau d'alimentation par une double isolation ou une isolation renforcée (fondée sur une tension de service égale à la tension du réseau d'alimentation).

Les circuits TBTS ou TBTP doivent être isolés des autres circuits non TBTS ou non TBTP (sauf TBTF) par une double isolation ou une isolation renforcée (fondée sur une tension de service égale à la tension la plus élevée dans les circuits).

Les circuits TBTS ou TBTP doivent être isolés des circuits TBTF par une isolation supplémentaire (fondée sur une tension de service égale à la tension du réseau d'alimentation).

Les circuits TBTS ou TBTP doivent être isolés des autres circuits TBTS ou TBTP par l'isolation principale (fondée sur une tension de service égale à la tension la plus élevée dans les circuits).

Les circuits TBTS ou TBTP doivent être isolés des parties conductrices accessibles par une isolation conformément au Tableau T.1.

Dans le cas d'un appareillage conforme à la série IEC 61347, la tension TBTS ou TBTP à prendre en compte pour l'isolation est la tension de sortie maximale indiquée sur l'appareillage comme "U-OUT".

La conformité est vérifiée par examen et par l'essai exigé à l'Article 10, à l'Article 12 et à l'Article 13.

Les fiches et les socles de prise de courant dans les schémas TBTS ou TBTP doivent satisfaire aux exigences suivantes:

- les fiches ne doivent pas être capables d'établir un contact électrique avec les socles de systèmes correspondant à d'autres tensions;
- les socles ne doivent pas admettre des fiches de systèmes correspondant à d'autres tensions;
- les fiches et les socles de prise de courant dans les circuits TBTS ne doivent pas avoir de contact avec un conducteur de protection.

La conformité est vérifiée par examen et essai.

7.31.3 Circuits TBTF

Les sources suivantes peuvent être utilisées pour alimenter les circuits TBTF:

- un transformateur de séparation conformément à l'IEC 61558-2-1 ou à une partie équivalente de la série IEC 61558-2;
- un appareillage de séparation qui fournit une isolation principale entre les circuits d'entrée et de sortie conformément à la série IEC 61347;
- une source électrochimique (par exemple une batterie) d'une autre source dans un circuit séparé du réseau d'alimentation uniquement par l'isolation principale.

La tension dans les circuits ne doit pas être supérieure aux limites définies pour la TBT.

Les circuits TBTF doivent être isolés de l'alimentation réseau au moins par l'isolation principale (fondée sur une tension de service égale à la tension d'alimentation réseau).

Il n'est pas exigé que les circuits TBTF soient isolés de terre de protection sauf à des fins fonctionnelles.

Les circuits TBTF doivent être isolés des parties conductrices accessibles par une isolation conformément au Tableau T.1.

La conformité est vérifiée par examen et par les essais exigés aux Articles 10, 12 et 13.

Les fiches et les socles de prise de courant dans les schémas TBTF doivent satisfaire aux exigences suivantes:

- les fiches ne doivent pas être capables d'établir un contact électrique avec les socles de systèmes correspondant à d'autres tensions;
- les socles ne doivent pas admettre des fiches de systèmes correspondant à d'autres tensions;
- les socles doivent avoir un contact avec un conducteur de protection.

La conformité est vérifiée par examen et essai.

7.31.4 Autres circuits

L'isolation entre les circuits autres que TBTS, TBTP ou TBTF et les parties conductrices accessibles doit être conforme aux exigences du Tableau T.1.

Dans la construction de classe II, où la liaison équipotentielle est utilisée pour la protection contre les contacts indirects avec les parties actives dangereuses (voir Tableau T.1), les exigences suivantes s'appliquent.

- Toutes les parties conductrices sont connectées les unes aux autres afin que deux défaillances de l'isolation entraînent un court-circuit.
- Pour vérifier si les parties conductrices sont connectées les unes aux autres de façon fiable, l'essai du 9.2.3 (essai de continuité de la terre avec 10 A) doit être effectué.
- Dans le cas d'un défaut d'isolation entre les parties actives dangereuses et les parties conductrices accessibles, la partie conductrice ne doit pas devenir une partie pouvant être la cause d'un choc électrique conformément à l'Annexe A.
- Pour les applications où un ou plusieurs luminaires sont alimentés par un autre luminaire (l'appareillage de commande est installé dans le luminaire qui assure l'alimentation), une liaison équipotentielle entre les luminaires doit être utilisée afin d'éviter les tensions dangereuses entre les luminaires accessibles. Pour cette raison, le luminaire qui assure l'alimentation doit être fourni avec une borne pour connecter les parties conductrices accessibles des autres luminaires et les autres luminaires doivent être construits en tant que luminaires de classe I.

La conformité est vérifiée en appliquant les exigences du présent document afin de vérifier l'isolation exigée à l'Annexe T.

NOTE Exemples de ce type de circuits:

- circuits de sortie d'appareillage de commande conformément à la série IEC 61347;
- circuits alimentés par un transformateur d'isolement conformément à l'IEC 61558-2-4 ou à une partie équivalente de la série IEC 61558-2;
- circuits alimentés par des transformateurs de séparation conformément à l'IEC 61558-2-1 qui ne satisfont pas aux exigences de TBTF;
- circuits alimentés par un appareillage de séparation (autre que TBTF) et un appareillage d'isolation conformément à la série IEC 61347.

7.31.5 Exigences supplémentaires pour les luminaires qui utilisent des appareillages commandables qui fournissent une ou plusieurs sorties TBTS

Les luminaires avec des accès de contrôle externes (c'est-à-dire contrôlés par un circuit câblé externe) et avec des appareillages de commande réglables qui fournissent une ou plusieurs sorties TBTS doivent utiliser des appareillages de commande avec une isolation entre la ou les sorties TBTS et les accès de contrôle TBTS (bornes, par exemple). L'isolation entre la ou les sorties TBTS de l'appareillage de commande et ses accès de contrôle doit satisfaire aux exigences de l'IEC 61347-1 pour les appareillages de commande interconnectés.

NOTE 1 Cela permet de réduire le risque d'une accumulation dangereuse de courant de contact en raison de la somme de chaque courant de contact d'autres luminaires dans la même installation.

NOTE 2 L'exigence susmentionnée peut être respectée par d'autres composants (par exemple, des optocoupleurs externes ou des dispositifs similaires) du luminaire qui fournissent le même niveau d'isolation entre les deux circuits.

NOTE 3 Des informations relatives à l'isolation entre le circuit de sortie et l'accès de contrôle de l'appareillage de commande peuvent être consultées sur la feuille de caractéristiques du fabricant.

NOTE 4 Pour les luminaires sans accès de contrôle pour une connexion externe, il n'est pas nécessaire d'utiliser un appareillage de commande avec isolation entre la sortie TBTS et l'accès/la borne de contrôle TBTS, car la limitation du courant de contact est couverte lors de l'application de l'Article 10 et du 12.3.

La conformité est vérifiée par examen et par l'essai associé exigé dans le présent document.

7.32 Appareils de protection contre les surtensions externes aux appareillages de commande

7.32.1 Généralités

Pour limiter les effets des surtensions dues à la foudre et d'autres surtensions transitoires, des dispositifs de protection contre les surtensions peuvent être utilisés dans les luminaires et ils peuvent être des dispositifs de protection contre les surtensions (SPD, *Surge Protective Devices*) ou des composants de protection contre les surtensions (SPC, *Surge Protective Components*). Les SPD et les SPC dans les luminaires doivent satisfaire aux exigences données respectivement en 7.32.2 et en 7.32.3.

Les SPD ou les SPC qui exigent une connexion à la terre doivent être utilisés uniquement dans des luminaires fixes et raccordés à la terre de protection (luminaires de classe I).

NOTE 1 Des exemples de SPC sont les varistances à oxyde métallique (MOV, *Metal Oxide Varistors*) et les tubes à décharge de gaz (TDG). Les SPD utilisent des SPC et constituent un ensemble complet.

NOTE 2 Les exigences des 7.32.2 et 7.32.3 s'appliquent aux SPD et aux SPC externes à l'appareillage de commande. Ces composants utilisés à l'intérieur d'un appareillage de commande sont déjà soumis à l'essai conformément à la norme relative aux appareillages de commande qui couvre toutes les conditions de fonctionnement possibles, y compris les défauts.

7.32.2 Dispositifs de protection contre les surtensions (SPD)

Les SPD doivent satisfaire à l'IEC 61643-11 et aux exigences supplémentaires suivantes:

La température ambiante assignée du SPD doit être adaptée aux conditions à l'intérieur du luminaire. Cela est vérifié conformément à l'essai du 14.4 du présent document.

7.32.3 Composants de protection contre les surtensions (SPC)

7.32.3.1 Généralités

Les SPC couverts par le 7.32.3 sont ceux connectés à travers le réseau d'alimentation (L à L ou L à N). Les SPC ne doivent pas être raccordés à la terre ni à d'autres parties conductrices du luminaire.

NOTE Les exigences relatives aux SPC connectés à la terre sont à l'étude.

Les SPC externes aux appareillages de commande doivent satisfaire aux exigences de l'IEC 61051-2:2021 ou de l'IEC 61643-331:2020 et doivent satisfaire aux exigences supplémentaires énumérées du 7.32.3.2 au 7.32.3.6.

7.32.3.2 Conditions climatiques

Pour le choix du dispositif, les SPC doivent satisfaire à l'une des conditions climatiques suivantes, selon les options A ou B:

Option A – Catégories climatiques (voir l'IEC 61051-2:2021, 4.1):

- la température ambiante maximale des SPC doit être adaptée à la condition à l'intérieur du luminaire. Cela est vérifié conformément à l'essai du 14.4 du présent document;
- durée de l'essai continu de chaleur humide: 21 jours;

ou

Option B – Plages de températures de fonctionnement et de stockage (voir l'IEC 61643-331:2020, 4.1):

- la température ambiante maximale des SPC doit être adaptée à la condition à l'intérieur du luminaire. Cela est vérifié conformément à l'essai du 14.4 du présent document.

NOTE La température ambiante est égale à la température microambiante à l'intérieur du luminaire, mesurée à proximité du dispositif.

7.32.3.3 Tension continue maximale

La tension continue maximale assignée du dispositif SPC doit être:

- au moins 1,25 fois la tension assignée du luminaire, ou
- au moins 1,25 fois la tension la plus élevée de la plage de tensions assignée du luminaire.

7.32.3.4 Capacité de surtension

Le SPC doit être adapté au courant de décharge nominal (utilisé dans l'essai sur ondes combinées) comme cela est indiqué dans le Tableau 10:

Tableau 10 – Courant de décharge nominal (utilisé dans l'essai sur ondes combinées)

Tension du réseau d'alimentation	Combinaison d'impulsions (courant de court-circuit de tension en circuit ouvert)
≤ 300 V	2,5 kV
	1,25 kA
> 300 V et ≤ 600 V	4 kV
	2 kA
> 600 V et ≤ 1 000 V	6 kV
	3 kA

7.32.3.5 Résistance au feu du SPC

Le corps du SPC doit satisfaire à l'essai au brûleur-aiguille conformément à l'IEC 60695-11-5, avec les sévérités d'essai suivantes:

- durée d'application de la flamme d'essai: 10 s;
- durée de la flamme après retrait: 5 s.

Toute goutte enflammée qui tombe de l'échantillon ne doit pas enflammer le papier de soie, comme cela est indiqué dans l'IEC 60695-11-5.

La conformité est vérifiée en effectuant l'essai au brûleur-aiguille ci-dessus sur les SPC et en satisfaisant à la sévérité de l'essai.

Comme le corps du SPC peut devenir chaud en fonctionnement, les exigences du 7.15.1 du présent document doivent être appliquées en tenant compte du corps du SPC comme partie chauffée qui peut amener les matériaux à leur température d'inflammation.

7.32.3.6 Essai de surcharge du SPC

Cet essai doit être effectué dans le luminaire en déconnectant tous les autres circuits, laissant uniquement le SPC connecté en série à une résistance d'essai. Si le SPC satisfait aux exigences de l'IEC 61643-331 en tant que SPC thermiquement protégé, cet essai n'est pas exigé.

L'essai suivant est réalisé sur un SPC raccordé au réseau (L à L ou L à N) et l'essai est destiné à simuler la surchauffe du SPC en fonctionnement afin d'éviter tout dommage au composant et à la partie environnante du luminaire.

Le circuit de simulation d'essai suivant doit être utilisé:

- la tension est la source en courant alternatif de $2 \times U_r$;
- le courant est le courant qui résulte d'une résistance d'essai (résistance R_x) connectée en série à la source en courant alternatif;
- U_r est la tension assignée ou la tension supérieure de la plage de tensions assignée du luminaire.

L'essai doit être réalisé avec une résistance d'essai initiale $R_1 = (16 \times U_r) \Omega$.

Si le circuit ne s'ouvre pas immédiatement pendant l'application initiale du courant d'essai, l'essai doit se poursuivre jusqu'à la stabilité en température.

Par la suite, l'essai doit être répété avec de nouvelles valeurs de R_x (R_2, R_3, R_4 , etc.) jusqu'à ce que le circuit s'ouvre.

- $R_2 = (8 \times U_r) \Omega$
- $R_3 = (4 \times U_r) \Omega$
- $R_4 = (2 \times U_r) \Omega$
- $R_x = (0,5 \times R_{(x-1)}) \Omega$

Au cours de l'essai, il ne doit y avoir aucune émission de flammes ou de matériau fondu ni production de gaz inflammables. Après l'essai, la ligne de fuite et la distance de sécurité ne doivent pas être réduites et aucune partie du luminaire ne doit présenter une déformation qui compromet la sécurité.

Pour vérifier si les gaz libérés par les composants sont ou non inflammables, un essai avec un générateur d'étincelles à haute fréquence doit être effectué.

Au cours de l'essai, le circuit peut s'ouvrir en raison du fonctionnement d'un dispositif de protection tel qu'un fusible ou un fusible thermique.

NOTE Cet essai couvre le comportement en fin de vie d'un SPC et aucune protection supplémentaire n'est nécessaire dans le circuit.

7.33 Luminaire alimenté par le biais d'un câblage de communication informatique

Un luminaire alimenté par le biais d'un câblage de communication informatique doit satisfaire aux exigences applicables à la classe III.

La tension assignée du luminaire ne doit pas excéder la tension maximale associée au connecteur utilisé.

NOTE 1 Il est prévu qu'une utilisation à l'intérieur soit la principale application des luminaires alimentés par un câblage de communication informatique; toutefois, lorsqu'ils sont utilisés dans d'autres applications, des exigences supplémentaires relatives à une utilisation à l'extérieur et au degré IP peuvent s'avérer nécessaires.

Le luminaire doit être conçu de manière à respecter les limites des paramètres électriques d'un PSE. L'Annexe U fournit des informations sur les limites d'un PSE.

Le luminaire ne doit pas engendrer de danger lorsqu'il est alimenté à

- 130 % de la tension d'entrée assignée du luminaire au niveau des bornes d'alimentation pour les circuits supérieurs à 5 V en courant continu, avec un minimum de 7,5 V en courant continu, et
- 150 % de la tension d'entrée assignée du luminaire au niveau des bornes d'alimentation pour les circuits inférieurs ou égaux à 5 V en courant continu.

Toute défaillance consécutive des composants du luminaire ne doit pas créer de danger.

NOTE 2 Cette condition de défaut dans le PSE est une condition anormale pour le luminaire.

La conformité est vérifiée par les essais de l'Article 14.

7.34 Champs électromagnétiques (EMF)

Les luminaires ne doivent pas produire de champs électromagnétiques nuisibles.

La conformité est vérifiée conformément à l'IEC 62493:2015 et l'IEC 62493:2015/AMD1:2022.

NOTE L'IEC 62493:2015, 4.2.2 décrit les types courants de constructions de luminaire qui sont considérés comme conformes aux exigences de cette norme EMF sans qu'il soit nécessaire de réaliser un essai.

7.35 Protection contre les pales de ventilateur en mouvement

Les pales de ventilateur motorisé pour le refroidissement actif des luminaires ne doivent pas être accessibles lorsque le luminaire est installé et câblé comme en utilisation normale, et lorsqu'il est ouvert au besoin pour remplacer les sources de lumière remplaçables ou les composants (remplaçables). L'essai est effectué avec un doigt d'épreuve normalisé (calibre d'essai B selon l'IEC 61032:1997, Figure 2), lorsqu'il est inséré dans les ouvertures avec une force de 30 N. Pour les luminaires portatifs, le calibre d'essai 19 selon l'IEC 61032:1997, Figure 13 doit être utilisé pour cet essai. Cet essai n'est pas effectué pour les ventilateurs dont les bords d'attaque et les extrémités sont arrondis avec un rayon d'au moins 0,5 mm et:

- dont la dureté Shore est inférieure à D60; ou
- dont la vitesse périphérique est inférieure à 15 m/s lorsqu'ils sont alimentés à la tension assignée; ou
- dont la puissance d'entrée ne dépasse pas 2 W lorsqu'ils sont alimentés à la tension assignée.

NOTE D60 est référencé dans l'ISO 48-4:2018.

La conformité à cette exigence est vérifiée par examen et, si nécessaire, par un essai avec le calibre d'essai pertinent. Le calibre d'essai doit être appliqué dans chaque position possible avec la force spécifiée. Aucun contact avec la pale du ventilateur ne doit se produire.

7.36 Luminaires montés sur rail

En outre, les luminaires montés sur rail doivent être soumis à l'essai conformément à l'IEC 60570:2003/AMD2:2019, Annexe A.

8 Câblage externe et interne

8.1 Généralités

L'Article 8 spécifie les exigences générales pour le raccordement électrique au réseau d'alimentation et pour le câblage interne des luminaires.

8.2 Raccordement au réseau et autres câblages externes

8.2.1 Les luminaires doivent être équipés de l'un des moyens suivants de raccordement au réseau d'alimentation:

a) luminaires fixes:

- dispositifs de raccordement des luminaires;
- bornes; fiches pour engagement dans les socles de prise de courant;
- câbles de raccordement (sorties).

Si le luminaire est livré avec des câbles de raccordement (sorties) et sans moyen de raccordement au réseau, le fabricant du luminaire doit spécifier le bloc de jonction qui peut être utilisé et qui doit être conforme à l'IEC 60998-2-1 ou à l'IEC 60998-2-2; soit le bloc de jonction à utiliser doit être spécifié, soit les informations suivantes doivent être précisées:

- le type de borne (avec vis ou sans vis);
- le nombre de bornes;
- la tension assignée;
- la capacité assignée de connexion;
- toute préparation nécessaire des extrémités des conducteurs;
- toute méthode de fixation.

Les exigences des 7.6, 7.7.1, 7.7.2, 7.10.1, 13.2, de l'Article 14 et du 15.2 doivent s'appliquer;

- cordons d'alimentation;
- adaptateurs pour engagement avec rails d'alimentation;
- socles de connecteur;
- coupleurs d'installation;
- luminaires de classe III alimentés par le biais d'un câblage de communication informatique ayant les connecteurs appropriés, par exemple les fiches décrites dans la série IEC 60603 et la série IEC 62680;

b) luminaires portatifs:

- cordons d'alimentation; avec fiches; socles de connecteur;
- luminaires de classe III alimentés par le biais d'un câblage de communication informatique ayant les connecteurs appropriés, par exemple les fiches décrites dans la série IEC 60603 et la série IEC 62680;

c) luminaires montés sur rail:

- adaptateurs ou connecteurs;

d) semi-luminaires:

- vis Edison ou culots à baïonnette.

Les luminaires portatifs prévus pour être montés en applique, équipés d'une boîte de dérivation et d'un dispositif d'arrêt de traction incorporés peuvent être livrés sans cordon d'alimentation, à condition qu'ils soient accompagnés des instructions de montage.

Les luminaires déclarés par le fabricant pour être utilisés à l'extérieur ne doivent pas avoir un câblage externe isolé en PVC. Ces exigences ne sont pas applicables aux circuits de classe III ou TBTS ou TBTP dans les luminaires (jusqu'à et inclus 25 V en courant alternatif ou 60 V en courant continu ou 25 V crête en courant continu interrompu avec une fréquence comprise entre 10 Hz et 200 Hz) et au câblage externe protégé de l'environnement extérieur par d'autres moyens, par exemple un câblage entre le compartiment lampe et la connexion à l'alimentation réseau entrante (dans toute sa longueur) d'un candélabre.

NOTE 1 En Australie, en Autriche et au Japon, les câbles ayant une isolation en PVC peuvent être utilisés à l'extérieur.

NOTE 2 Un luminaire pour montage en applique peut être considéré comme portatif s'il est fixé à son support au moyen de vis à oreilles, de pinces ou de crochets (voir 3.9).

NOTE 3 Dans certains pays, les luminaires conçus pour être connectés au réseau par l'intermédiaire d'un socle de prise de courant ont besoin d'être livrés équipés d'un cordon d'alimentation et d'une fiche appropriée.

8.2.2 Les cordons d'alimentation utilisés pour le raccordement au réseau, lorsqu'ils sont livrés par le fabricant du luminaire, doivent avoir des qualités mécaniques et électriques au moins égales à celles qui sont spécifiées dans la série IEC 60227 et la série IEC 60245, comme cela est indiqué dans le Tableau 11, et être en état de supporter, sans se détériorer, les températures les plus élevées auxquelles ils peuvent être soumis dans les conditions normales de fonctionnement.

Des matériaux autres que le polychlorure de vinyle et le caoutchouc sont acceptables si les exigences ci-dessus sont respectées, mais, dans ce cas, les spécifications particulières de l'IEC 60227-2 et l'IEC 60245-2 ne sont pas applicables.

Les conducteurs à isolation principale non gainés doivent être soumis à l'essai de rigidité diélectrique spécifié à l'Article 12 pour TBTS ou TBTP (500 V).

Tableau 11 – Cordons d'alimentation

Luminaire	Caoutchouc	PVC	Sans isolation
Luminaires ordinaires de la classe I	60245 IEC 89 ^c	60227 IEC 52 ^c	
Luminaires ordinaires de la classe II	60245 IEC 53 ^c	60227 IEC 52 ^c	
Luminaires autres que les luminaires ordinaires de classe I et de classe II	60245 IEC 57 ^c	60227 IEC 52 ^{a c}	
Luminaires portatifs pour conditions sévères d'emploi	60245 IEC 66 ^c		
Luminaires de classe III ou à circuits TBTS ou TBTP Courant alternatif: $U \leq 25$ V Courant continu: $U \leq 60$ V Tension en courant continu interrompu pour des fréquences comprises entre 10 Hz et 200 Hz: ≤ 25 V crête			Conducteur non isolé ^b
Luminaires de classe III ou à circuits TBTS ou TBTP Courant alternatif: 25 V $< U \leq 50$ V Courant continu: 60 V $< U \leq 120$ V			Conducteur à isolation principale non gainé
^a Pour utilisation intérieure uniquement ^b Conformément à la série IEC 60364, les conducteurs non isolés ne sont pas autorisés dans certaines installations et certains lieux spécifiques, par exemple les locaux contenant une baignoire ou une douche (IEC 60364-7-701). ^c Pour les tensions d'alimentation supérieures à 250 V, des câbles et des cordons de catégories de tensions plus élevées que celles qui sont données dans ce tableau peuvent être nécessaires.			

Pour assurer une résistance mécanique appropriée, la section nominale des conducteurs de câblage externe, par exemple, du cordon d'alimentation et des câbles d'interconnexion, ne doit pas être inférieure à la valeur spécifiée dans le Tableau 12.

Tableau 12 – Caractéristiques du câblage

Condition	Section minimale nominale du conducteur ⁱ	
	mm ²	
	Luminaire ordinaire	Autre luminaire
Généralités	0,75	1,0
Déclarée être "Pour utilisation intérieure uniquement", conformément au 6.4.15.	0,75	0,75
Lorsque le luminaire est équipé d'un socle de prise de courant 10/16 A.	1,5	1,5
Luminaires de classe III ou connexions à circuits TBTS ou TBTP entre des parties d'autres types de luminaires, avec un courant maximal assigné de 2 A.	0,4 ^{a c}	0,4 ^{a c}
Luminaires de classe III ou connexions à circuits TBTS ou TBTP entre des parties d'autres types de luminaires, avec un courant maximal assigné de 2 A, comprenant des câbles ayant deux conducteurs ou plus.	0,2 ^{a b c}	0,2 ^{a b c}
Conducteurs raccordés à l'appareillage TBTS ou TBTP qui limite le courant de sortie à 2 A au maximum.	< 0,2 (Aucune valeur minimale) ^{d e g h}	< 0,2 (Aucune valeur minimale) ^{d f g h}
<p>^a À condition que le courant admissible et les propriétés mécaniques soient adéquats.</p> <p>^b Capable de résister au courant normal et de court-circuit fourni par l'appareillage associé.</p> <p>^c La conformité est vérifiée par examen et par l'essai du 8.2.10.</p> <p>^d Choisie en fonction du courant maximal disponible; la conformité est vérifiée par l'essai du 8.4.</p> <p>^e La tension de sortie de l'appareillage sous charge ne dépasse pas 25 V en valeur efficace ou 60 V en courant continu lisse et une tension à vide ne dépasse pas 35 V en valeur de crête ou 60 V en courant continu lisse.</p> <p>^f Tension de sortie de l'appareillage qui ne dépasse pas 12 V en valeur efficace ou 30 V en courant continu lisse.</p> <p>^g Pour vérifier les propriétés mécaniques, l'ensemble du conducteur, fixé sur le luminaire, doit être soumis à l'essai du 8.2.10.4.</p> <p>^h L'épaisseur minimale d'isolation doit être choisie pour résister aux contraintes de tension, voir Tableau T.1.</p> <p>ⁱ L'IEC 60228 spécifie que l'exigence associée à la section nominale du conducteur est une valeur de résistance maximale et non une mesure physique de la zone. L'IEC 60228 indique ces valeurs pour les sections de dimensions nominales supérieures ou égales à 0,5 mm². Pour les sections inférieures, la valeur de résistance est calculée en conséquence.</p>		

8.2.3 Lorsque le luminaire est équipé d'un cordon d'alimentation, ce cordon doit être raccordé au luminaire par l'une des méthodes suivantes:

- fixation de type X;
- fixation de type Y;
- fixation de type Z.

8.2.4 La conformité aux exigences des 8.2.1 à 8.2.3 est vérifiée par examen et, si nécessaire, par la fixation sur le luminaire du câble ou cordon souple approprié.

8.2.5 Les bornes au sein des luminaires équipés de fixations de type Z ne doivent pas être réalisées par des connexions vissées.

8.2.6 Les entrées de câble doivent permettre l'introduction du tube ou du revêtement protecteur du câble ou du cordon souple, de sorte que les âmes soient complètement protégées; elles doivent également procurer un degré de protection contre les poussières ou l'humidité, en rapport avec la classification du luminaire, lorsque le tube ou le câble ou cordon souple est en place.

8.2.7 Les entrées de câble traversant des matériaux rigides pour câbles et cordons souples externes doivent avoir des bords légèrement arrondis à un rayon minimal de 0,5 mm.

La conformité aux exigences des 8.2.5 à 8.2.7 est vérifiée par examen et par des essais manuels.

8.2.8 Si, dans des luminaires de classe II, des luminaires réglables et ajustables ou des luminaires portatifs autres que des appliques, un câble ou cordon souple pénétrant dans le luminaire ou en sortant, traverse des parties métalliques accessibles ou des parties métalliques en contact avec ces parties métalliques accessibles, l'ouverture doit être équipée d'une traversée en matériau isolant rigide à bords légèrement arrondis, fixée de telle sorte qu'il ne soit pas facile de l'enlever. Les traversées dont la matière se détériore avec le temps ne doivent pas être employées dans des ouvertures à bords vifs.

NOTE 1 Le terme "traversée facilement enlevée" est utilisé pour décrire une traversée qui peut être retirée de son emplacement par des mouvements du luminaire durant sa période de fonctionnement ou par inadvertance en le manipulant. Des exemples de fixations acceptées incluent les écrous de serrage, les adhésifs appropriés tels que la résine autodurcissante, ou les bouchons de taille appropriée.

NOTE 2 Un exemple de matériau connu pour sa détérioration avec le temps est le caoutchouc naturel.

Si des tubes ou autres revêtements protecteurs procurent la protection des câbles ou cordons souples à leur point de pénétration dans le luminaire, ils doivent être réalisés dans une matière isolante.

Les ressorts métalliques hélicoïdaux et les dispositifs analogues, même recouverts d'une matière isolante, ne sont pas considérés comme revêtements protecteurs.

La conformité est vérifiée par examen.

8.2.9 Les traversées qui se vissent dans le luminaire doivent être bloquées en position. Si elles sont fixées au moyen d'une colle, celle-ci doit être du type résine autodurcissante.

La conformité est vérifiée par examen.

8.2.10 Les dispositifs d'arrêt de traction doivent être conformes aux exigences des 8.2.10.1 à 8.2.10.5.

8.2.10.1 À moins qu'ils ne satisfassent aux exigences du 8.2.10.5, les luminaires équipés ou conçus pour être utilisés avec un cordon d'alimentation ou autre câble ou cordon souple extérieur doivent être équipés d'un dispositif d'arrêt de traction afin de soustraire les conducteurs aux contraintes, y compris la torsion, lorsqu'ils sont raccordés aux bornes, et de telle sorte que leur revêtement soit protégé contre l'abrasion. La manière dont le dispositif d'arrêt de traction et de torsion assure sa fonction doit apparaître clairement. Pour les luminaires livrés sans câble ou cordon souple, les essais doivent être effectués avec des câbles ou cordons souples appropriés, ayant les dimensions minimales et maximales recommandées par le fabricant.

Il ne doit pas être possible de repousser dans le luminaire le câble ou cordon souple jusqu'à le soumettre à des contraintes mécaniques ou thermiques excessives. Les méthodes consistant à nouer le câble ou cordon ou à fixer les extrémités avec une ficelle doivent être proscrites.

Les dispositifs d'arrêt de traction doivent être en matériau isolant ou être fournis avec revêtement isolant fixe si un défaut d'isolation du câble ou cordon peut rendre accessibles des parties métalliques sous tension.

8.2.10.2 Les dispositifs d'arrêt de traction pour les fixations de type X doivent être réalisés et localisés de telle façon:

a) qu'une partie au moins soit fixée ou intégrée au luminaire;

NOTE Un dispositif d'arrêt de traction est considéré comme fixé au luminaire, ou maintenu par ce dernier si tel est le cas, lorsque le câblage y est inséré et le luminaire complètement assemblé.

b) qu'ils conviennent pour les différents types de cordons d'alimentation adaptés au raccordement au luminaire, sauf si le luminaire ne permet que le raccordement d'un seul type de câble ou de cordon d'alimentation;

c) qu'ils ne détériorent pas le cordon d'alimentation et ne soient pas susceptibles d'être endommagés lorsqu'ils sont serrés ou desserrés en usage normal;

d) que la totalité du cordon d'alimentation avec son revêtement protecteur, s'il existe, puisse être montée dans le dispositif d'arrêt de traction;

e) que le cordon d'alimentation ne vienne pas en contact avec les vis de fixation du dispositif d'arrêt de traction si ces vis sont métalliques et accessibles ou connectées électriquement à des parties métalliques accessibles;

f) que le cordon d'alimentation ne soit pas fixé par une vis métallique s'appuyant directement sur le cordon ou le câble d'alimentation;

g) que le remplacement du cordon d'alimentation n'exige pas l'utilisation d'un outil spécial conçu pour cela.

Les presse-étoupes des luminaires portatifs ou des luminaires réglables et ajustables ne doivent pas servir de dispositifs d'arrêt de traction, à moins qu'ils ne comportent un dispositif de serrage convenant à tous les types et à toutes les dimensions de câbles ou de cordons qui peuvent être utilisés pour le raccordement au réseau. Les ancrages en forme de labyrinthe peuvent être employés si la conception ou un marquage convenable indique de façon évidente la façon dont le câble ou le cordon souple doit être monté.

La conformité est vérifiée par l'essai du 8.2.10.4.

8.2.10.3 Pour les fixations de types Y et Z, les dispositifs d'arrêt de traction doivent être appropriés.

La conformité est vérifiée par l'essai du 8.2.10.4. L'essai est réalisé avec le câble ou le cordon fourni avec le luminaire.

8.2.10.4 *La conformité est vérifiée par examen et par les essais suivants qui sont effectués sur le câble ou le cordon équipant le luminaire à la livraison.*

Les conducteurs sont introduits dans les bornes et les vis des bornes, s'il y en a, sont serrées juste assez pour éviter tout déplacement facile des conducteurs.

Le dispositif d'arrêt de traction est utilisé de la manière normale, les vis de serrage, s'il y en a, étant serrées avec un couple égal aux deux tiers de celui spécifié dans le Tableau 5.

Après cette préparation, il ne doit pas être possible de repousser dans le luminaire le câble ou le cordon jusqu'à provoquer son déplacement dans les bornes, ou de l'amener au contact de parties mobiles, ou de parties fonctionnant à une température supérieure à celle qui est autorisée pour l'isolation des conducteurs.

Le câble ou le cordon est ensuite soumis, 25 fois de suite, à une force de traction de valeur spécifiée dans le Tableau 13.

Les tractions sont appliquées sans secousse, chaque fois pendant 1 s. Le mesurage du déplacement longitudinal du câble ou du cordon est effectué pendant cet essai. Un repère est tracé sur le câble ou le cordon à une distance d'environ 20 mm du dispositif d'arrêt de traction alors qu'il est soumis à la première traction et, pendant la 25^e traction, le repère ne doit pas s'être déplacé de plus de 2 mm.

Le câble ou le cordon doit être ensuite soumis à un couple de torsion de valeur spécifiée dans le Tableau 13.

Pendant et après les essais ci-dessus, les conducteurs ne doivent pas s'être déplacés de manière perceptible dans les bornes et le câble ou le cordon ne doit pas être détérioré. S'il peut être considéré que les bornes travaillent en partie comme dispositifs d'arrêt de traction (par exemple, parce que les fils entre le dispositif d'arrêt de traction et la borne sont allongés), l'essai doit être répété avec une connexion ouverte entre les conducteurs et les bornes, afin d'assurer que la fonction de dispositif d'arrêt de traction est indépendante de la connexion électrique.

Tableau 13 – Essais du dispositif d'arrêt de traction

Section nominale totale de tous les conducteurs pris ensemble mm ²	Force de traction N	Couple de torsion Nm
Jusqu'à 0,4 inclus	30	-----
Au-dessus de 0,4 jusqu'à 0,75 inclus	30	0,08
Au-dessus de 0,75 jusqu'à 1,5 inclus	60	0,15
Au-dessus de 1,5 jusqu'à 3 inclus	60	0,25
Au-dessus de 3 jusqu'à 5 inclus	80	0,35
Au-dessus de 5 jusqu'à 8 inclus	120	0,35

8.2.10.5 Les luminaires équipés ou conçus pour être utilisés avec un cordon d'alimentation ou autre câble ou cordon souple extérieur peuvent être exemptés de la nécessité d'un dispositif d'arrêt de traction s'ils ont un courant maximal de 2 A, y compris le courant de court-circuit disponible dans le circuit avant le fonctionnement d'un appareil qui limite la surintensité, et si les conditions et l'exigence d'essai suivantes sont respectées:

- luminaires ordinaires de classe III alimentés en TBTS à une tension ne dépassant pas 25 V en valeur efficace ou 60 V en courant continu lisse;
- luminaires ordinaires de classe III alimentés en TBTP à une tension ne dépassant pas 12 V en valeur efficace ou 30 V en courant continu lisse;
- luminaires autres que luminaires ordinaires de classe III alimentés à une tension ne dépassant pas 12 V en valeur efficace ou 30 V en courant continu lisse.

L'exigence d'essai suivante doit être respectée.

Chaque conducteur d'un faisceau équipé connecté au circuit doit être soumis à un essai de traction de 30 N. La force de traction est appliquée sans secousses, pendant 1 min, dans la direction opposée au sens d'application ou d'introduction du conducteur nu ou du faisceau équipé. Pendant l'essai, le conducteur nu ou le faisceau équipé ne doit pas s'être déplacé de manière perceptible dans les bornes ni s'être déconnecté en cas de soudure. Si le conducteur, le cordon ou le câble peut être repoussé dans l'enveloppe, tout contact avec des parties actives dangereuses, des pièces chaudes qui dépassent la température assignée du conducteur, du cordon ou du câble et tout contact avec des parties mobiles susceptibles de les endommager doivent être empêchés.

8.2.11 Si un câblage externe pénètre dans le luminaire, il doit satisfaire aux exigences appropriées du câblage interne.

La conformité est vérifiée par les essais du 8.3.

8.2.12 Les luminaires fixes prévus pour le repiquage doivent être fournis avec des bornes prévues pour le maintien de la continuité électrique des câbles qui alimentent le luminaire, mais ne s'y terminent pas.

La conformité est vérifiée par examen.

8.2.13 Les extrémités de conducteurs toronnés souples peuvent être étamées, mais ne doivent pas comporter de soudure excédentaire, à moins qu'une disposition ne permette d'assurer que les connexions, une fois serrées, ne peuvent pas se desserrer par suite du relâchement à froid de la soudure (voir Figure 36).

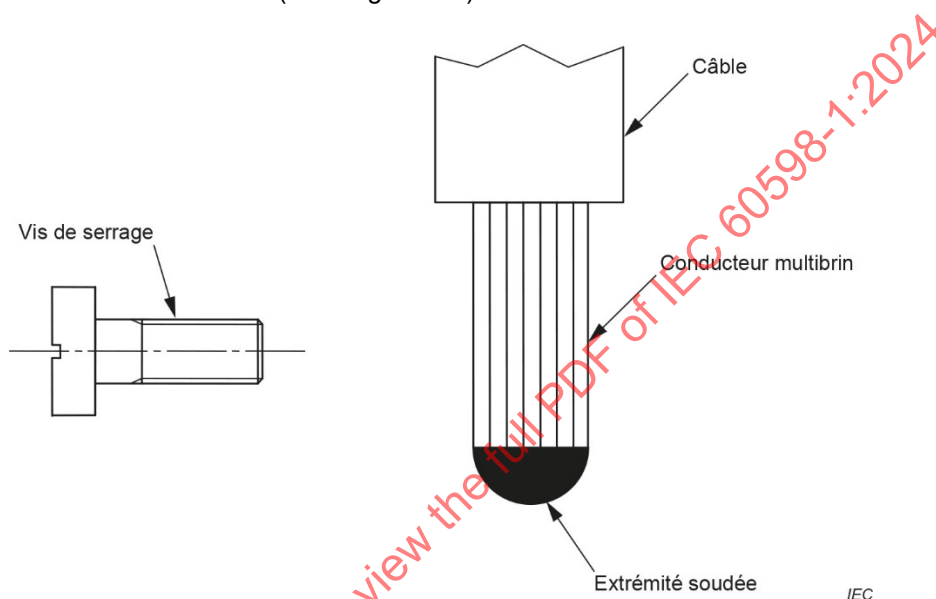

Figure 36 – Exemple de degré d'étamage admis

EXEMPLE Cette exigence est respectée lorsque des bornes à ressort sont utilisées. L'immobilisation des vis de fixation n'est pas un moyen satisfaisant pour prévenir le desserrage des brins soudés d'un conducteur par suite du relâchement à froid de la soudure.

La conformité est vérifiée par examen.

8.2.14 Lorsque le luminaire est livré par le fabricant avec une fiche de prise de courant, celle-ci doit procurer le même degré de protection contre les chocs électriques, les poussières, les corps solides et l'humidité que le luminaire.

Les fiches moulées sont réputées satisfaire aux exigences IP des luminaires autres qu'ordinaires à usage domestique.

NOTE 1 Dans certains pays (par exemple Royaume-Uni et Australie), lorsque la législation nationale exige l'installation d'une certaine fiche qui ne procure pas le degré de protection exigé, le fabricant de luminaires doit fournir des indications claires pour la connexion au réseau de façon à procurer un degré de protection contre la pénétration nocive d'humidité et de poussières identique à celui procuré par le luminaire.

Un luminaire de classe III ne doit pas être fourni avec une fiche permettant une connexion électrique avec un socle de prise de courant conforme à l'IEC TR 60083 ou les branchements au réseau ou les connecteurs au réseau conformément à la série IEC 60320.

Il ne doit pas y avoir de compatibilité dangereuse entre les coupleurs pour la classe II et la classe III et les systèmes spécifiés dans les feuilles de norme de la série IEC 60320 et les systèmes fiche et socle de prise de courant domestiques nationaux du pays dans lequel le luminaire est mis sur le marché.

NOTE 2 Pour la conformité à l'exigence ci-dessus, le fabricant peut fournir la liste des pays où le luminaire est mis sur le marché et où aucun risque de compatibilité fiche-socket dangereuse n'a été relevé.

La conformité est vérifiée par examen et par l'essai suivant (voir Figure 37).

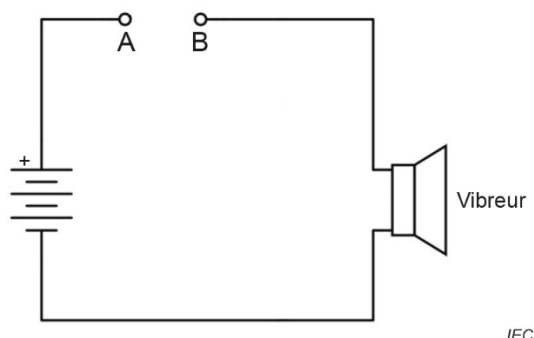

Figure 37 – Circuit pour vérifier le contact électrique entre un socle de prise de courant et une fiche

Le pôle A est connecté à tous les contacts du socle et le Pôle B est connecté à tous les contacts de la fiche. Pendant l'insertion, le vibreur ne doit pas fonctionner.

NOTE 3 Certains systèmes fiches et socles nationaux sont présentés dans l'IEC TR 60083.

Les fiches et socles des luminaires de classe III, lorsqu'un transformateur d'isolation de sécurité est fourni avec le luminaire, ayant à la fois un courant assigné ≤ 3 A et une tension assignée ≤ 25 V en courant alternatif ou ≤ 60 V en courant continu avec une puissance qui ne dépasse pas 72 W, sont uniquement acceptés avec les exigences suivantes:

- les fiches ne doivent pas être capables d'établir un contact électrique avec les socles de prise de courant de systèmes correspondant à d'autres tensions (conformément à l'IEC TR 60083);
- les socles ne doivent pas admettre des fiches de systèmes correspondant à d'autres tensions;
- les socles ne doivent pas avoir un contact de terre de protection.

Pour ces systèmes fiche et socles de prise de courant particuliers, l'essai de pression à la bille de l'Article 15 n'est pas applicable.

8.2.15 Pour les luminaires de classe III alimentés par le biais d'un câblage de communication informatique, le raccordement au réseau d'alimentation doit être effectué au moyen de connecteurs conformes à la série IEC 60603 ou à la série IEC 62680.

NOTE Les exigences stipulées pour PoE sont adaptées de l'IEC 62368-3:2017.

La conformité est vérifiée par examen.

8.2.16 Les socles de connecteur en courant alternatif incorporés aux luminaires pour le raccordement au réseau d'alimentation doivent satisfaire aux exigences de la série IEC 60320. Pour les luminaires fixes, des coupleurs d'installation conformes à l'IEC 61535 peuvent être utilisés de manière alternative. Dans ce cas, il doit être vérifié que les conditions d'utilisation recommandées par le fabricant des coupleurs ont été prises en compte (IEC 61535:2023, 8.4).

NOTE La série IEC 60320 inclut d'autres configurations qui ne font pas partie de la feuille de norme correspondante.

Si les connexions ou les systèmes de connexion des socles de connecteur conformes à l'IEC 61984 sont utilisés conformément à leur utilisation prévue et leurs caractéristiques assignées, les exigences suivantes doivent être appliquées:

a) Polarisation

Il ne doit pas y avoir de compatibilité dangereuse entre les pôles de connecteurs conformément à l'IEC 61984:2008, 6.3.

b) Protection contre les chocs électriques

Des connecteurs à enveloppe fermée doivent être utilisés si le connecteur est accessible en utilisation normale.

c) Dispositif mécanique de blocage

Les connecteurs sans pouvoir de coupure (COC, *Connectors without breaking capacity*) définis dans l'IEC 61984:2008, 3.9, doivent être équipés d'un dispositif mécanique de blocage entre le socle de prise de courant et la fiche. Les dispositifs de blocage dans lesquels la fonction de blocage peut être activée manuellement sont admis. Les connecteurs à pouvoir de coupure (CBC, *Connectors with Breaking Capacity*) définis dans l'IEC 61984:2008, 3.8, peuvent être fournis sans dispositif de blocage.

d) Établissement rapide du contact

L'établissement rapide d'un contact de terre de protection est également exigé pour les connecteurs conçus avec des contacts ne s'établissant que dans une condition sans charge.

e) Protection contre les courts-circuits de pôles

Si des fils toronnés sont utilisés, une protection doit être prévue contre tout court-circuit non intentionnel provoqué par un brin libre. L'essai de l'IEC 61535:2023, 12.8.2 s'applique en retirant une longueur de brin de 6 mm.

f) Serre-câble

Les connecteurs pour câblage externe doivent être équipés d'un serre-câble conformément à l'IEC 61984:2008, 6.17.

La conformité est vérifiée par examen.

8.2.17 Les câbles d'interconnexion, s'ils ne sont pas constitués de câbles isolés et gainés normalisés, doivent être constitués d'un assemblage défini réalisé par le fabricant de luminaires avec des câbles équipés de gaines, tubes ou de construction équivalente.

8.2.18 Tous les luminaires portatifs et luminaires fixes ou les luminaires destinés à être connectés au réseau d'alimentation par l'intermédiaire d'un socle de prise de courant doivent être équipés d'une fiche conformément à l'IEC TR 60083, ou aux normes régionales ou nationales applicables, selon la classification du luminaire.

La conformité est vérifiée par examen.

8.3 Câblage interne

8.3.1

8.3.1.1 Le câblage interne doit être réalisé avec des conducteurs de taille et de type appropriés de façon à supporter la puissance entrant en jeu lors d'une utilisation normale. L'isolation du câblage doit être réalisée dans un matériau capable de supporter la tension et la température maximale auxquelles il est soumis, sans altérer la sécurité lorsqu'il est installé et connecté correctement au réseau.

Si des câbles avec un type d'isolation ordinaire (PVC ou caoutchouc) sont utilisés comme ligne traversante, il n'est pas nécessaire de livrer ces câbles avec le luminaire, si la procédure de montage est clairement expliquée dans les instructions du fabricant. Cependant, si des câbles spéciaux ou des gaines spéciales sont nécessaires, par exemple en raison de températures élevées, la ligne traversante doit toujours être assemblée en usine. Les exigences du 6.4.4 c) doivent être prises en considération dans le dernier cas.

Les fils de couleurs jaune et verte combinées doivent être utilisés uniquement pour des connexions de terre de protection.

NOTE Les limites de température pour l'isolation sont données dans le Tableau 22.

Les gaines conformes au 7.9.2 sont appropriées pour protéger les points chauds.

La conformité est vérifiée par examen et par les essais de l'Article 14.

8.3.1.2 Pour ce qui est du câblage y compris les câbles de raccordement (sorties) connecté directement au câble de l'installation fixe par l'intermédiaire d'un bloc de jonction, par exemple, et lorsque la déconnexion du réseau dépend d'un ou de plusieurs appareils de protection externe, ce qui suit s'applique.

Pour des courants de fonctionnement normaux de 2 A et supérieurs:

- section nominale: 0,5 mm² au minimum;
- pour la ligne traversante des luminaires fixes: 1,5 mm² au minimum;
- pour les épaisseurs d'isolation nominales: 0,6 mm au minimum (PVC ou caoutchouc).

Pour le câblage protégé mécaniquement des courants de fonctionnement normaux inférieurs à 2 A:

- section nominale: 0,4 mm² au minimum;
- pour les épaisseurs d'isolation nominales: 0,5 mm au minimum (PVC ou caoutchouc).

La protection mécanique exigée est considérée comme appropriée lorsqu'une isolation supplémentaire est ajoutée aux endroits suivants où l'isolation des fils peut être endommagée:

- dans les petites ouvertures de tubes lorsque, durant la production, les fils sont glissés à l'intérieur;
- lorsque les fils sont courbés à proximité des parties métalliques qui n'ont pas été spécialement façonnées pour avoir des extrémités lisses.

8.3.1.3 Pour le câblage qui est connecté au câblage fixe par l'intermédiaire d'un appareil limitant le courant à 2 A au maximum, par exemple appareils de contrôle du courant lampe, coupe-circuit, fusibles, impédance de protection ou transformateurs d'isolement, ce qui suit s'applique:

- la section minimale peut être inférieure à 0,4 mm² si une surchauffe de l'isolation du fil conducteur est empêchée dans des conditions de fonctionnement normales et en court-circuit conformément aux essais du 8.4;
- l'épaisseur d'isolation minimale, qui peut être inférieure à 0,5 mm (PVC ou caoutchouc), doit être choisie en fonction de la contrainte de tension impliquée, voir Tableau T.1;
- la valeur assignée de la limite de courant de l'appareil de protection doit être une caractéristique reconnue de l'appareil utilisé.

NOTE Voir aussi 4.3.

8.3.1.4 Dans les luminaires de classe II dont le câblage interne possède un conducteur actif dangereux qui touche une partie métallique accessible dans les conditions de fonctionnement normales, l'isolation, au moins à l'endroit du contact, doit satisfaire aux exigences de la double isolation ou de l'isolation renforcée correspondant à la contrainte de tension, en utilisant par exemple des câbles gainés ou des gaines.

8.3.1.5 Des conducteurs sans isolation peuvent être utilisés à condition que des précautions appropriées aient été prises pour assurer le respect des exigences relatives aux lignes de fuite et aux distances dans l'air de l'Article 13 et également en fonction de la classe de protection définie à l'Article 5.

8.3.1.6 Les parties conduisant des courants TBTS ou TBTP ne doivent pas être isolées. Cependant, si une isolation est appliquée, elle doit être soumise à l'essai comme cela est décrit à l'Article 12.

8.3.1.7 Quand des matériaux isolants qui ont des propriétés mécaniques ou d'isolation plus élevées que le PVC ou le caoutchouc sont utilisés, l'épaisseur d'isolation doit être choisie de façon à procurer le même degré de protection contre les chocs électriques.

8.3.2 Le câblage interne doit être situé ou protégé de telle sorte qu'il ne puisse pas être endommagé par des bords, rivets, vis ou autres composants vifs, ou par des parties mobiles d'interrupteur, de raccords, d'appareils à contrepoids, de tubes télescopiques ou de parties analogues. Le câblage ne doit pas subir de torsion supérieure à 360° le long de l'axe longitudinal du câble.

La conformité est vérifiée par examen (voir aussi 7.14.4 et 7.14.5) et conformément à l'essai du 7.14.3.

8.3.3 Si, dans des luminaires de classe II, des luminaires réglables et ajustables, ou des luminaires portatifs autres que les appliques, le câblage interne traverse des parties métalliques accessibles ou des parties métalliques en contact avec ces dernières, l'entrée doit être équipée d'une traversée rigide en matériau isolant, à bords légèrement arrondis, fixée de telle sorte qu'elle ne soit pas facile à enlever. Les traversées dont la matière se détériore avec le temps ne doivent pas être employées dans des ouvertures à bords vifs.

NOTE 1 Le terme "traversée facilement enlevée" est utilisé pour décrire une traversée qui peut être retirée de son emplacement par des mouvements du luminaire durant sa période de fonctionnement ou par inadvertance en le manipulant. Des exemples de fixations acceptées incluent les écrous de serrage, les adhésifs appropriés tels que la résine autodurcissante, ou les bouchons de taille appropriée.

NOTE 2 Un exemple de matériau connu pour sa détérioration avec le temps est le caoutchouc naturel.

Si les ouvertures d'entrée de câble ont des bords légèrement arrondis et le câblage interne ne doit pas être déplacé en service, cette exigence est respectée par l'emploi d'une gaine de protection séparée autour d'un câble qui ne présente aucune gaine protectrice spéciale, ou par l'emploi d'un câble qui est équipé d'une telle gaine.

8.3.4 Les raccords et branchements du câblage interne, à l'exception des bornes de raccordement des composants, doivent être équipés d'un recouvrement isolant d'une efficacité qui ne soit pas inférieure à l'isolation du câblage.

La conformité aux exigences des 8.3.3 et 8.3.4 est vérifiée par examen.

8.3.5 Lorsque le câblage interne sort du luminaire et que la conception de l'appareil est telle que le câblage peut être soumis à des contraintes, les exigences concernant le câblage externe sont applicables. Les exigences pour le câblage externe ne s'appliquent pas au câblage interne des luminaires ordinaires de longueur qui ne dépasse pas 80 mm à l'extérieur du luminaire. Pour les luminaires autres que les luminaires ordinaires, la totalité du câblage externe à l'enveloppe doit satisfaire aux exigences du câblage externe.

La conformité est vérifiée par examen, par des mesurages et, le cas échéant, conformément aux essais et conditions du 8.2.10.2 ou du 8.2.10.5.

8.3.6 Le câblage des luminaires réglables et ajustables doit être fixé au moyen de cavaliers, de pinces ou autres pièces analogues, en matériau isolant, en tout endroit où, sans cette précaution, les conducteurs peuvent frotter contre des parties métalliques sous l'effet des mouvements normaux du luminaire de manière que l'isolation puisse être endommagée.

8.3.7 Les extrémités de conducteurs toronnés souples peuvent être étamées, mais ne doivent pas comporter de soudure excédentaire, à moins qu'une disposition ne permette d'assurer que les connexions, une fois serrées, ne peuvent pas se desserrer par suite du relâchement à froid de la soudure (voir Figure 36).

EXEMPLE Cette exigence est respectée lorsque des bornes à ressort sont utilisées. L'immobilisation des vis de fixation n'est pas un moyen satisfaisant pour prévenir le desserrage des brins soudés d'un conducteur par suite du relâchement à froid de la soudure.

La conformité aux exigences des 8.3.6 et 8.3.7 est vérifiée par examen.

8.4 Essai pour déterminer l'adéquation des conducteurs ayant une section transversale réduite

Pour déterminer l'adéquation des conducteurs ayant une section transversale réduite, reliés à l'appareillage qui limite le courant à 2A, l'essai suivant doit être effectué:

- a) déconnecter les conducteurs en essai aussi près que possible de la source de lumière dans le luminaire et fixer une charge résistive à l'aide de fils d'essai de section minimale de 1 mm^2 ; ces fils doivent être acheminés hors du luminaire de manière à avoir le moindre impact sur les températures dans le luminaire;
- b) régler la charge résistive pour mesurer le courant de sortie maximal de l'appareillage; le courant maximal mesuré ne doit pas dépasser 2 A;
- c) la charge résistive étant réglée pour débiter le courant de sortie maximal, effectuer l'essai d'échauffement conformément au 14.4 (voir Figure 38);
- d) régler ensuite la charge résistive sur 0Ω (court-circuit) et répéter l'essai d'échauffement conformément au 14.4 (voir Figure 38).

En aucun cas, la température de l'isolation du câblage du luminaire ne doit dépasser les limites indiquées dans le Tableau 22 et le câblage du luminaire ne doit présenter aucun signe de dommage.

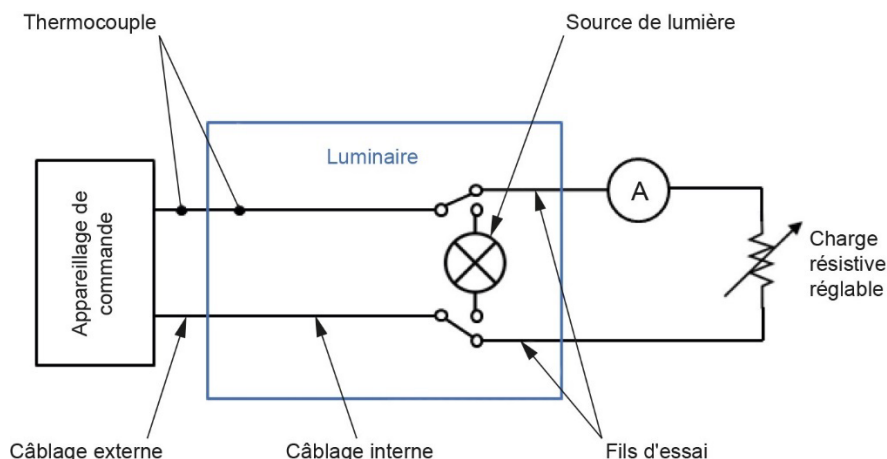

La charge résistive est réglable et capable de présenter une faible résistance (proche de 0 Ω).

NOTE L'appareillage peut être interne au luminaire.

Figure 38 – Essai pour déterminer l'adéquation des conducteurs ayant une section transversale réduite

9 Dispositions en vue de la mise à la terre

9.1 Généralités

L'Article 9 spécifie les exigences, lorsqu'elles sont applicables, pour la mise à la terre des luminaires.

9.2 Dispositions en vue de la mise à la terre

9.2.1 Les parties métalliques des luminaires de classe I qui sont accessibles après la pose du luminaire ou quand ce dernier est ouvert pour remplacement d'une source de lumière ou d'un starter ou à des fins de nettoyage, et qui peuvent devenir des parties actives dangereuses en cas d'un défaut d'isolation, doivent être raccordées de manière durable et fiable à une borne ou à un contact de terre de protection.

Les parties métalliques séparées des parties actives dangereuses par des pièces métalliques qui sont raccordées à une borne ou à un contact de terre de protection, et les parties métalliques séparées des parties actives dangereuses par une double isolation, ou par une isolation renforcée, ne sont pas, dans le cadre de cette exigence, considérées comme susceptibles de devenir des parties actives dangereuses en cas de défaut d'isolement.

NOTE 1 Si une lampe se brise pendant le remplacement de lampes, la casse de la lampe n'est pas considérée comme un défaut d'isolation au sens du 9.2.1, car la lampe dans ce cas n'est pas considérée comme faisant partie du luminaire (voir 4.2.2 et 10.2.3, point a) pour clarification).

Les parties métalliques des luminaires qui peuvent devenir des parties actives dangereuses dans le cas d'un défaut d'isolation, et qui ne sont pas accessibles une fois le luminaire installé, mais qui sont susceptibles d'entrer en contact avec la surface de montage, doivent être raccordées de manière durable et d'une façon fiable à une borne de terre de protection.

NOTE 2 La mise à la terre des starters et des culots de lampes n'est pas une exigence, mais la mise à la terre des culots de lampes peut être nécessaire pour faciliter l'amorçage.

Les connexions de mise à la terre pour des raisons de protection doivent présenter une faible résistance.

Les vis autotaraudeuses peuvent être utilisées pour réaliser une continuité de terre de protection à la condition qu'elles permettent de satisfaire aux exigences du 7.12.1.

Les vis autotaraudeuses (par déformation de matière) peuvent être utilisées pour réaliser une continuité de terre de protection.

Une vis autotaraudeuse utilisée dans une rainure en matériau métallique d'un luminaire assure la continuité de terre de protection pour un luminaire si tous les essais exigés par le présent document en ce qui concerne la connexion de mise à la terre pour des raisons de protection sont réussis. Voir Figure 39.

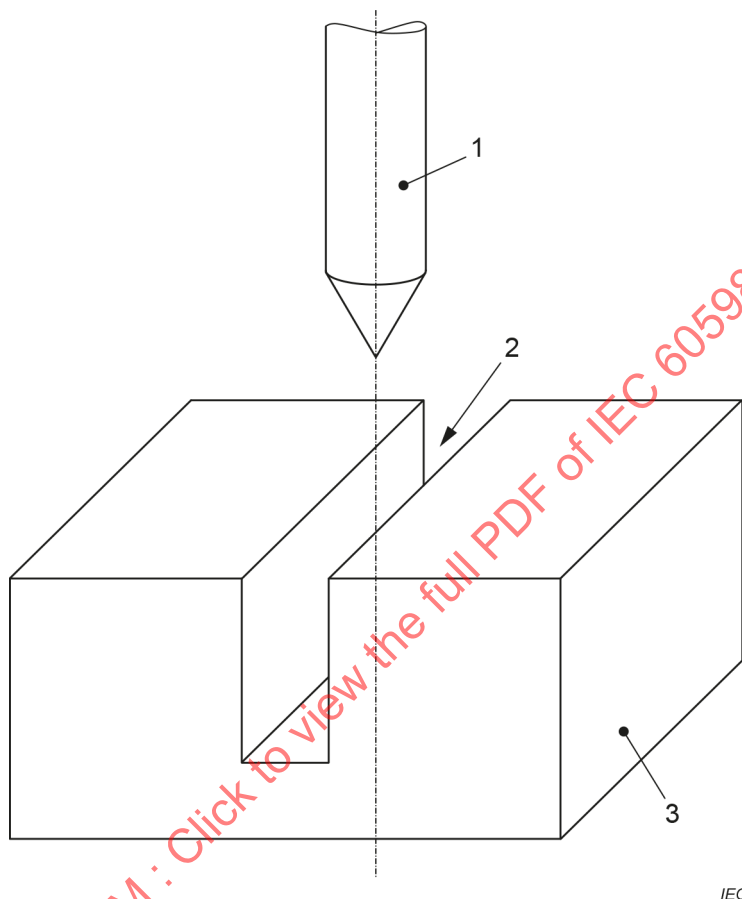

Légende

- 1 vis autotaraudeuse
- 2 rainure
- 3 matériau métallique

Figure 39 – Exemple de vis autotaraudeuse utilisée dans la rainure d'un matériau métallique

Dans les luminaires de classe I à parties amovibles équipés de connecteurs ou d'appareils de raccordement similaires, la connexion de mise à la terre pour des raisons de protection doit être effectuée avant celle des contacts transportant du courant et les contacts transportant du courant doivent se séparer avant que la connexion de mise à la terre pour des raisons de protection ne soit interrompue.

Pour les blocs de jonction avec contacts automatiques de terre de protection intégrés, les essais additionnels de l'Annexe R doivent être appliqués.

Il est admis de mettre à la terre l'appareillage de commande intégré en le fixant à des parties métalliques mises à la terre du luminaire. La connexion de mise à la terre pour des raisons de protection du luminaire par l'intermédiaire de l'appareillage de commande intégré n'est pas admise.

9.2.2 Les surfaces des raccords réglables et en cours d'utilisation, des tubes télescopiques, etc., assurant la continuité de terre de protection, doivent être conçues de manière à assurer un bon contact électrique.

9.2.3 *La conformité aux exigences des 9.2.1 et 9.2.2 est vérifiée par examen et, pour la terre de protection, par l'essai suivant.*

Un courant d'au moins 10 A, qui provient d'une source dont la tension à vide ne dépasse pas 12 V, doit passer tour à tour entre la borne ou le contact de terre et chacune des parties métalliques accessibles.

La chute de tension entre la borne ou le contact de terre et la partie métallique accessible doit être mesurée et la résistance calculée à partir du courant et de la chute de tension. En aucun cas cette résistance ne doit être supérieure à 0,5 Ω. Lors de l'essai de type, le courant doit être appliqué pendant une durée d'au moins 1 min.

NOTE Dans le cas d'un luminaire avec cordon d'alimentation, le contact de terre est situé sur la fiche de prise de courant ou à l'extrémité du câble ou cordon d'alimentation souple.

9.2.4 Les bornes de terre de protection doivent satisfaire aux exigences du 7.7.3. Le raccordement doit être convenablement assuré contre le desserrage accidentel.

Pour les bornes à vis, il ne doit pas être possible de desserrer le dispositif de serrage à la main.

Pour les bornes sans vis, il ne doit pas être possible de desserrer le dispositif de serrage involontairement.

La conformité est vérifiée par examen, par un essai manuel et par les essais spécifiés en 7.7.3.

NOTE En général, les conceptions habituellement employées pour les bornes transportant du courant fournissent une résistance mécanique suffisante pour satisfaire à cette exigence; pour d'autres conceptions, des dispositions spéciales peuvent être nécessaires, comme l'emploi d'une pièce d'élasticité convenable qui n'est pas susceptible d'être enlevée par inadvertance.

Pour les blocs de jonction avec contacts automatiques de terre de protection intégrés, les essais additionnels de l'Annexe R s'appliquent.

9.2.5 Dans le cas d'un luminaire équipé d'un socle de connexion pour un raccordement au réseau d'alimentation, le contact de terre doit faire partie intégrante du socle.

9.2.6 Dans le cas d'un luminaire à raccorder à des câbles d'alimentation (câblage fixe) ou à un cordon d'alimentation, la borne de terre doit être adjacente à la borne de réseau.

NOTE Les luminaires peuvent être équipés de fixations de type X ou de type Y.

9.2.7 Pour les luminaires autres que les luminaires ordinaires, toutes les parties d'une borne de terre de protection doivent être prévues pour réduire le plus possible le risque de corrosion électrolytique provenant du contact avec le conducteur de terre ou tout autre métal en contact avec elles.

9.2.8 La vis ou l'autre partie de la borne de terre de protection doit être en laiton ou en tout autre métal inoxydable ou en un matériau dont la surface soit inoxydable et les surfaces de contact doivent être en métal nu.

9.2.9 *La conformité aux exigences des 9.2.5 à 9.2.8 est vérifiée par examen et par essai manuel.*

9.2.10 Si un luminaire fixe de classe II est équipé d'une ou de plusieurs bornes internes et de circuits internes destinés à assurer la continuité électrique d'un conducteur de terre de protection (par exemple, pour un repiquage ou une ligne traversante), ces bornes internes et circuits doivent être isolés des parties actives dangereuses par une isolation principale.

Si un luminaire fixe connecté de classe II dispose d'une connexion de mise à la terre fonctionnelle, le circuit de terre fonctionnel doit être séparé des parties actives dangereuses par une double isolation ou une isolation renforcée.

La conformité est vérifiée par examen et par les essais correspondants exigés pour l'isolation.

9.2.11 Lorsqu'un luminaire de classe I est fourni avec un cordon d'alimentation, ce cordon doit comporter un conducteur de mise à la terre de couleur vert-jaune.

L'âme vert-jaune d'un cordon d'alimentation doit être raccordée à la borne de terre de protection du luminaire et au contact de terre de la fiche si elle est fixée au luminaire.

Tout conducteur, qu'il soit interne ou externe, identifié par la combinaison de couleur vert-jaune, doit être raccordé exclusivement à une borne de terre de protection.

Pour les luminaires avec cordons d'alimentation, la disposition des bornes, ou la longueur des conducteurs entre le dispositif d'arrêt de traction et les bornes, doit être telle que, même si le câble ou cordon quitte le dispositif d'arrêt de traction, le conducteur qui transporte du courant devienne tendu avant le conducteur de terre de protection.

La conformité est vérifiée par examen.

9.2.12 Lorsqu'un circuit TBTP est relié à une terre de protection à des fins fonctionnelles, ce circuit ne doit pas être utilisé pour l'interconnexion avec d'autres luminaires afin d'éviter une surcharge du conducteur du circuit.

NOTE La surcharge du conducteur peut être due à un courant de défaut qui provient d'un autre point du circuit de terre d'un bâtiment mis à la terre.

10 Protection contre les chocs électriques

10.1 Généralités

L'Article 10 spécifie les exigences de protection contre les chocs électriques en ce qui concerne les luminaires. Un essai qui a pour but de déterminer si une partie conductrice est une partie active dangereuse qui peut entraîner des chocs électriques est décrit à l'Annexe A.

10.2 Protection contre les chocs électriques

10.2.1 Les luminaires doivent être conçus de manière que leurs parties actives dangereuses ne soient pas accessibles après la pose et le câblage du luminaire en utilisation normale, ainsi que lorsqu'ils sont ouverts pour le remplacement des sources de lumière remplaçables ou pour l'accès à d'autres composants remplaçables, même si ces opérations ne peuvent pas être effectuées à la main. Les parties à isolation principale ne doivent pas être utilisées sur la surface externe du luminaire sans protection appropriée contre les contacts accidentels.

NOTE 1 Des exemples de parties à isolation principale sont le câblage interne, l'appareillage de commande intégré.

Lorsqu'une vasque de protection est utilisée par-dessus une source de lumière non remplaçable par l'utilisateur ou un composant non remplaçable par l'utilisateur final conformément au 7.30, la vasque doit rester en place lors des essais et des contrôles décrits à l'Article 10. Pour les composants remplaçables autres que les lampes, toutes les opérations nécessaires pour remplacer le composant (y compris la déconnexion et la reconnexion) et toutes les opérations exigées pour ajuster ou régler les composants ne doivent pas donner accès à des parties actives dangereuses.

Aucun accès aux parties actives dangereuses avec le doigt d'épreuve normalisé (calibre d'essai B selon l'IEC 61032:1997, Figure 2) n'est admis lorsque le luminaire assemblé a été installé comme pour une utilisation normale et, de plus, dans les conditions suivantes:

- pour les luminaires portatifs et les luminaires réglables et ajustables, aucun accès aux parties à isolation principale avec le doigt d'épreuve normalisé (calibre d'essai B selon l'IEC 61032:1997, Figure 2) n'est admis; et
- pour les autres types de luminaires, il ne doit pas être possible d'accéder aux parties à isolation principale depuis l'extérieur du luminaire à l'aide d'un calibre de 50 mm de diamètre selon l'IEC 61032:1997, Figure 1.

Les douilles de lampe et de starter, lorsqu'elles sont utilisées dans les luminaires portatifs et les luminaires réglables et ajustables et dans le cas où elles sont accessibles comme cela est spécifié ci-dessus, doivent satisfaire aux essais de rigidité diélectrique et aux exigences relatives aux lignes de fuite et aux distances dans l'air correspondant à la double isolation ou à l'isolation renforcée.

NOTE 2 Des lignes de fuite et distances dans l'air suffisantes sur les surfaces extérieures accessibles ne peuvent souvent être respectées qu'après montage dans le luminaire.

NOTE 3 Des informations sur les douilles de lampe et starters satisfaisant aux exigences ci-dessus peuvent être consultées dans la documentation du fabricant.

L'isolation principale peut être accessible lorsque le luminaire est ouvert pour le remplacement de la source de lumière ou du starter ou pour l'accès aux composants remplaçables.

Si un composant destiné à être intégré dans le luminaire est utilisé sur la partie externe d'un luminaire complètement assemblé, et s'il peut être touché avec la sphère de 50 mm, il doit satisfaire aux exigences correspondant aux composants indépendants (voir 3.32).

À moins que cela ne soit spécifiquement exigé, les lampes, les douilles de lampe et de starter satisfaisant à leur propre norme sont exemptes des exigences du 10.2.1.

La protection contre les chocs électriques doit être maintenue pour toutes les méthodes et positions d'installation dans une utilisation normale, compte tenu des limites indiquées dans les instructions d'installation du fabricant, et pour tous les réglages des luminaires réglables et ajustables. La protection doit être maintenue après l'enlèvement de toutes les parties qu'il est possible d'enlever à la main, à l'exception des lampes et des parties suivantes des douilles de lampe:

- a) pour les douilles pour culots à baïonnette:
 - 1) les calottes (couvre-bornes);
 - 2) les collerettes.
- b) pour les douilles à vis Edison:
 - 1) les calottes (couvre-bornes) pour les types à serre-fils seulement;
 - 2) les chemises extérieures.

Les vasques des luminaires fixes, qui ne peuvent être retirées par une action simple avec une seule main, ne sont pas retirées. Toutefois, les vasques qui doivent être retirées pour changer les sources de lumière et accéder aux composants remplaçables (à l'exception des sources de lumière et composants non remplaçables par l'utilisateur et des sources de lumière et composants non remplaçables) ou les starters sont retirés pour cet essai.

NOTE 4 Une action simple d'une seule main est normalement effectuée pour retirer des pièces telles que les vis à tête moletée ou une bague d'abat-jour.

Les conducteurs d'alimentation maintenus par des bornes sans vis avec des appareils de bouton-poussoir à relâchement ne doivent pas être enlevés pour le présent essai.

L'emploi d'un bloc de jonction du type bouton-poussoir, sans utiliser une partie couvrante, n'est pas exclu par la présente exigence. Cela est possible puisque des actions spécifiques sont exigées afin de dégager le câblage de ces blocs.

Les luminaires de classe I et classe II conçus pour les lampes tubulaires à filament de tungstène ou des lampes équivalentes de remplacement équipées de culots/socles à chaque extrémité doivent comporter un dispositif bipolaire qui assure leur mise hors circuit automatique lors du remplacement de la lampe. Cette exigence ne s'applique pas à la ou aux combinaisons concernées de culots et douilles conformes à des normes qui comprennent des exigences spéciales sur l'accessibilité des parties actives dangereuses qui peuvent provoquer un choc électrique.

Les propriétés isolantes des vernis, émaux, papiers et matériaux similaires ne doivent pas être considérées comme procurant la protection exigée contre les chocs électriques ni la protection contre les courts-circuits.

Les luminaires avec amorceurs, prévus pour utilisation avec des lampes à décharge haute pression à deux extrémités, doivent être soumis à l'essai conformément à la Figure 19.

Si la tension mesurée selon la Figure 19 dépasse 34 V (crête), l'amorceur ne doit devenir actif que lorsque la lampe est complètement insérée, ou bien un avertissement conformément au 6.3.18 a) ou b), respectivement, doit être installé sur le luminaire.

Les luminaires pour lampes tubulaires Fa8 à deux culots doivent satisfaire aux exigences de marquage du 6.3.18.

10.2.2 Pour les luminaires portatifs, la protection contre les chocs électriques doit également être maintenue lorsque les pièces mobiles de ces luminaires ont été placées dans la position la plus défavorable, cette opération pouvant être effectuée à la main.

10.2.3 Pour la protection contre les chocs électriques, les exigences additionnelles suivantes s'appliquent:

- a) les parties métalliques de luminaires de classe II qui sont isolées des parties actives dangereuses par une isolation principale uniquement sont considérées comme des parties actives dangereuses dans le cadre de l'Article 10. Le 10.2 s'applique dans les cas où aucune isolation électrique n'est prévue entre le réseau d'alimentation et les circuits de sortie de l'appareillage de commande. Lorsque l'appareillage de commande assure l'isolation principale ou une double isolation ou une isolation renforcée par rapport au réseau d'alimentation, l'isolation exigée entre la partie active dangereuse et la partie accessible doit être conforme au Tableau T.1.

Cela ne s'applique pas aux parties isolantes des culots des lampes qui satisfont à leur norme IEC correspondante.

Pour les luminaires de classe II, les ampoules en verre des lampes ne nécessitent pas d'avoir une autre protection contre les chocs électriques. Si des vasques en verre ou d'autres types de glaces de protection doivent être retirés pour remplacer la lampe ou s'ils ne résistent pas à l'essai du 7.13, ces éléments ne doivent pas servir d'isolation supplémentaire;

- b) les douilles métalliques pour les lampes culots à baïonnette des luminaires de classe I doivent être reliées à la terre de protection;
- c) les circuits TBTS peuvent avoir des parties conductrices accessibles dans les conditions suivantes.

– Pour les luminaires ordinaires:

- la tension à vide et la tension en charge n'excèdent pas:
 - pour les circuits en courant alternatif: 25 V en valeur efficace;
 - pour les circuits en courant continu: 60 V lisse;
 - pour la tension en courant continu interrompu pour des fréquences comprises entre 10 Hz et 200 Hz: 25 V crête;
- lorsque la tension excède 25 V en courant alternatif en valeur efficace ou 60 V en courant continu lisse, le courant de contact n'excède pas:
 - pour les circuits en courant alternatif: 0,7 mA (valeur de crête);
 - pour les circuits en courant continu: 2,0 mA (uniquement tension continue ininterrompue);
 - pour les circuits en courant continu interrompu ($f < 10$ Hz ou $f > 200$ Hz): 0,7 mA (valeur de crête);
 - pour les circuits en courant continu interrompu ($10 \text{ Hz} \leq f \leq 200 \text{ Hz}$): 0,41 mA (valeur de crête);

Si les tensions ou courants excèdent les valeurs indiquées ci-dessus, au moins un des pôles conducteurs du circuit TBTS doit être isolé par un isolant capable de résister à une tension d'essai de 500 V en valeur efficace pendant 1 min.

- Pour les luminaires autres qu'ordinaires, la tension nominale (en charge ou non) n'excède pas 12 V en valeur efficace ou 30 V en courant continu lisse ou 12 V crête en courant continu interrompu pour des fréquences comprises entre 10 Hz et 200 Hz. Lorsque le luminaire est ouvert pour le remplacement d'une source de lumière, les limites de tension des luminaires ordinaires s'appliquent (pour les parties uniquement accessibles lors de la maintenance).
- d) les circuits TBTP peuvent avoir des parties conductrices accessibles dans les conditions suivantes:
 - pour les luminaires ordinaires, la tension en charge ou à vide n'excède pas 12 V en valeur efficace ou 30 V en courant continu lisse;
 - pour les luminaires autres qu'ordinaires, la tension (en charge ou non) n'excède pas 12 V en valeur efficace ou 30 V en courant continu lisse.

Si les tensions excèdent les valeurs indiquées ci-dessus dans le circuit TBTP, seul le pôle relié à la terre peut être accessible. L'autre pôle doit être protégé par un isolant capable de résister à une tension d'essai de 500 V en valeur efficace pendant 1 min conformément au 12.2.3.

NOTE Ces limites sont issues de l'IEC 60364-4-41. Voir aussi Annexe A.

Les luminaires de classe III sont acceptés uniquement pour le raccordement à une source TBTS ou TBTP.

10.2.4 Les luminaires portatifs prévus pour raccordement au réseau d'alimentation au moyen d'un cordon d'alimentation et d'une fiche de connexion doivent comporter une protection contre les chocs électriques indépendante de la surface de montage.

10.2.5 La conformité aux exigences des 10.2.1 à 10.2.4 est vérifiée par examen et, si nécessaire, par l'essai avec le calibre d'essai correspondant conformément à l'IEC 61032:1997, Figure 1 et Figure 2, ou au moyen du doigt d'épreuve spécifique indiqué pour le composant en question.

Ce calibre d'essai doit être appliqué dans toutes les positions possibles, si nécessaire avec une force de 10 N; un témoin électrique est utilisé pour indiquer le contact avec des parties actives dangereuses. Les pièces amovibles, y compris les abat-jour, doivent être placées à la main, dans la position la plus défavorable; si ces pièces sont métalliques, elles ne doivent pas venir en contact avec des parties actives dangereuses du luminaire ou des lampes.

10.2.6 Les vasques et autres parties procurant une protection contre les chocs électriques doivent avoir une résistance mécanique suffisante et être immobilisées de façon sûre, de sorte qu'elles ne puissent pas prendre de jeu lors des manipulations normales.

La conformité est vérifiée par examen, par essai manuel et par les essais de l'Article 7.

Les appliques murales, luminaires portatifs et luminaires réglables et ajustables dont la fixation des vasques n'est pas réalisée au moyen de vis et dont l'enlèvement est obtenu en appliquant une force dans une direction approximativement perpendiculaire à la surface de montage doivent satisfaire à l'essai suivant:

Une force est appliquée approximativement perpendiculairement à la surface de montage. La force doit être de 20 N lorsque l'ouverture de la vasque donne accès aux parties à isolation principale et de 80 N pour les parties actives dangereuses.

Pendant l'essai la ou les vasques ne doivent pas prendre de jeu.

10.2.7 Les luminaires (autres que ceux mentionnés ci-dessous) comprenant un condensateur de capacitance supérieure à 0,5 μF doivent être fournis avec un appareil de décharge de façon que la tension aux bornes du condensateur ne dépasse pas 50 V 1 min après le débranchement du luminaire de la source d'alimentation à la tension assignée.

Les luminaires portatifs conçus pour être connectés au réseau d'alimentation au moyen d'une fiche, d'un adaptateur de rail, de luminaires connectés ou les luminaires avec un connecteur d'alimentation avec contacts accessibles au doigt d'épreuve normalisé (calibre d'essai B selon l'IEC 61032:1997, Figure 2), et incorporant un condensateur d'une capacitance supérieure à 0,1 μF (ou 0,25 μF pour les luminaires à tension assignée inférieure à 150 V) doivent être fournis avec un appareil de décharge, de façon que la tension entre les broches de la fiche ou les contacts de l'adaptateur ou du connecteur ne dépasse pas 34 V, 1 s après le débranchement du luminaire.

Les autres luminaires connectés au réseau d'alimentation au moyen d'une fiche et incorporant un condensateur supérieur à 0,1 μF (ou 0,25 μF pour les luminaires à tension assignée inférieure à 150 V) et les adaptateurs de rail montés dans les luminaires doivent se décharger de façon qu'après 5 s, la tension entre les broches de la fiche ne dépasse pas 60 V en valeur efficace.

Le 4.2.2 exige que les essais du présent document soient effectués sans une lampe dans le circuit, sauf spécification contraire. Dans le cas du présent 10.2.7, la lampe doit être dans le circuit lors du mesurage de la tension du condensateur, si cela conduit à un résultat plus défavorable.

Les tensions résiduelles auxquelles cette exigence fait référence doivent être mesurées sur un seul luminaire même s'il est envisageable qu'un tel luminaire puisse être installé dans un système à plusieurs luminaires.

La conformité est vérifiée par des mesurages.

NOTE L'appareil de décharge (pour tous les types de luminaires) peut être fixé sur le condensateur ou en faire partie ou être monté séparément à l'intérieur du luminaire.

11 Résistance à la poussière, aux corps solides et à l'humidité

11.1 Généralités

L'Article 11 spécifie les exigences et les essais applicables aux luminaires classés comme résistants aux poussières, aux corps solides et à l'humidité conformément à l'Article 5, y compris les luminaires ordinaires.

11.2 Conditions générales et essais pour la classification IP

11.2.1 Généralités

L'enveloppe du luminaire doit fournir le degré de protection contre la pénétration des poussières, des corps solides et de l'humidité, conformément à la classification du luminaire et au numéro IP marqué sur le luminaire.

NOTE 1 Les essais de protection contre les poussières, les corps solides et l'humidité spécifiés dans le présent document ne sont pas tous identiques à ceux de l'IEC 60529, à cause des caractéristiques techniques spécifiques aux luminaires. Le code de numérotation IP est expliqué à l'Annexe H.

La conformité est vérifiée par les essais appropriés des 11.2.2 à 11.2.13 et, pour d'autres degrés IP, par les essais appropriés de l'IEC 60529.

Le luminaire complet, avec la ou les lampes, doit, avant les essais relatifs au second chiffre caractéristique, IPX8 excepté, être allumé et porté, sous la tension assignée, à une température de fonctionnement stable.

L'eau employée pour les essais doit être à une température de $15\text{ °C} \pm 10\text{ °C}$ excepté pour IPX9 pour lequel la température doit être de $80\text{ °C} (\pm 5\text{ °C})$ ou de $15\text{ °C} (\pm 10\text{ °C})$ selon le marquage du luminaire.

Pour les essais des 11.2.2 à 11.2.13, les luminaires complets avec leurs vasques translucides de protection, s'il en existe, doivent être montés et câblés comme en utilisation normale, et placés dans la position la plus défavorable.

Lorsque la connexion est réalisée à l'aide d'une fiche ou d'un appareil similaire, celui-ci doit être considéré comme une partie du luminaire complet et doit être inclus dans les essais; il en est de même pour tout appareillage de commande séparé.

Pour les essais des 11.2.5 à 11.2.13, un luminaire fixe prévu pour être monté avec son corps en contact avec une surface doit être soumis à l'essai avec une entretoise en métal expansé interposée entre le luminaire et la surface de montage. L'entretoise doit être de dimensions au moins égales au périmètre du luminaire en contact avec la surface de montage, et avoir les caractéristiques suivantes:

grande dimension des mailles	10 mm à 20 mm;
petite dimension des mailles	4 mm à 7 mm;
largeur du toron	1,5 mm à 2 mm;
épaisseur du toron	0,3 mm à 0,5 mm;
épaisseur hors tout	1,8 mm à 3 mm.

Les luminaires prévus pour être drainés au moyen de trous de vidange doivent être mis en place, leur trou de vidange le plus bas étant ouvert, sauf spécification contraire dans les instructions d'installation du fabricant.

Si les instructions d'installation indiquent qu'un luminaire est destiné au montage au plafond, au mur ou sous un auvent, le luminaire doit être fixé à une planche ou une plaque plate qui déborde de 10 mm de la partie du périmètre du luminaire en contact avec la surface de montage.

Pour les luminaires IP2X, l'enveloppe dénote la partie du luminaire contenant la partie principale autre que la lampe et les mécanismes optiques.

NOTE 2 Puisque les luminaires n'ont pas de parties mobiles dangereuses, le niveau de sécurité spécifié dans l'IEC 60529 est obtenu.

Les luminaires portatifs, câblés comme en utilisation normale, doivent être placés dans la position la plus défavorable en usage normal.

Les presse-étoupes, s'ils existent, doivent être serrés avec un couple égal aux deux tiers de celui appliqué aux presse-étoupes au cours de l'essai du 7.12.4.

Les vis qui servent à fixer les vasques, autres que les vis posées à la main sur les vasques en verre, doivent être serrées avec un couple égal aux deux tiers de celui spécifié dans le Tableau 5.

Les couvercles vissés doivent être serrés avec un couple, exprimé en newtons-mètres, numériquement égal au dixième du diamètre nominal du filetage de la vis, exprimé en millimètres. Les vis qui fixent d'autres couvercles doivent être serrées avec un couple égal aux deux tiers de celui qui est spécifié dans le Tableau 5.

Après achèvement des essais, le luminaire doit pouvoir résister à l'essai de rigidité diélectrique spécifié à l'Article 12, et l'examen ne doit faire apparaître:

- a) *aucun dépôt de poudre de talc dans les luminaires protégés contre les poussières, d'une façon telle que si la poudre était conductrice, l'isolation ne répondrait plus aux exigences du présent document;*
- b) *aucun dépôt de poudre de talc à l'intérieur des enveloppes des luminaires étanches aux poussières;*
- c) *aucune trace d'eau sur les connexions électriques, les parties conductrices de courant ou sur l'isolation quand cela peut présenter un danger pour l'utilisateur ou l'environnement, par exemple quand cela peut réduire les lignes de fuite au-dessous des valeurs spécifiées à l'Article 13. La seule exception est pour les conducteurs TBTS ou TBTP pour lesquels la tension en charge ne dépasse pas 12 V crête en courant continu interrompu pour des fréquences comprises entre 10 Hz et 200 Hz, 12 V en valeur efficace ou 30 V en courant continu lisse et les conducteurs sont protégés de la corrosion.*

NOTE 3 Certains aspects de protection contre la corrosion sont couverts par le 7.18.

- 1) *Pour les luminaires sans trous de vidange, il ne doit pas y avoir d'entrée d'eau.*

NOTE 4 Des précautions sont prises afin de ne pas confondre condensation et entrée d'eau.

- 2) *Pour les luminaires avec trous de vidange, l'entrée d'eau et la condensation sont admises pendant les essais, si elles peuvent être évacuées efficacement et à condition de ne pas réduire les lignes de fuite et distances dans l'air au-dessous des niveaux minimaux spécifiés dans le présent document;*
- d) *aucune trace d'eau ayant pénétré dans quelque partie que ce soit d'un luminaire étanche à l'immersion ou à l'immersion sous pression ou d'un luminaire protégé contre les jets d'eau à haute pression et haute température ou d'un luminaire protégé contre les jets d'eau froide à haute pression;*

- e) *aucun contact admis avec les parties actives dangereuses par le calibre d'essai correspondant pour le premier chiffre 2 de la caractéristique IP;*
aucune pénétration dans l'enveloppe du luminaire par le calibre d'essai correspondant pour les premiers chiffres 3 et 4 de la caractéristique IP;
pour les luminaires avec trous de vidange conformes au 7.17 et les luminaires avec des fentes d'aération pour refroidissement forcé, aucun contact avec les parties actives dangereuses n'est admis à travers les trous de vidange et fentes d'aération avec le calibre d'essai correspondant pour les premiers chiffres 3 et 4 de la caractéristique IP;
- f) *aucune trace d'eau sur toutes les parties d'une lampe qui exigent une protection contre les éclaboussures d'eau comme cela est spécifié dans les "renseignements pour la conception des luminaires" de la norme de lampe concernée;*
- g) *aucun défaut, par exemple fissure ou cassure, d'un écran de protection ou de l'enveloppe en verre pouvant entraîner une altération de la sécurité ou de la protection contre l'humidité.*

11.2.2 Essais pour les premiers chiffres 2, 3 et 4 de la caractéristique IP

Les luminaires étanches aux corps solides (premier chiffre 2 de la caractéristique IP) doivent être soumis à l'essai avec le doigt d'épreuve normalisé (calibre d'essai B selon l'IEC 61032:1997, Figure 2) conformément aux exigences de l'Article 10 et de l'Article 13.

Les luminaires dont le premier chiffre de la caractéristique IP est 2 ne doivent pas être soumis à l'essai avec la sphère spécifiée dans l'IEC 60529.

Les luminaires étanches aux corps solides (premiers chiffres 3 et 4 de la caractéristique IP) doivent être soumis à l'essai en tous points possibles (joints d'étanchéité exclus) au moyen d'un calibre conforme au calibre d'essai C ou D de l'IEC 61032, appliqué avec une force spécifiée dans le Tableau 14.

Tableau 14 – Essai des luminaires étanches aux objets solides

	Calibre d'essai selon l'IEC 61032	Diamètre du fil d'épreuve	Force d'application N
Premier chiffre IP3	C	2,5 mm $\begin{matrix} +0,05 \\ 0,00 \end{matrix}$ mm	3 avec une tolérance de ± 10 %
Premier chiffre IP4	D	1 mm $\begin{matrix} +0,05 \\ 0,00 \end{matrix}$ mm	1 avec une tolérance de ± 10 %

L'extrémité du fil d'épreuve doit être coupée suivant une section droite et être exempte de bavures.

11.2.3 Essais pour les premiers chiffres 5 et 6 de la caractéristique IP

Les luminaires protégés contre les poussières (premier chiffre 5 de la caractéristique IP) et les luminaires étanches aux poussières (premier chiffre 6 de la caractéristique IP) doivent être soumis à l'essai dans une enceinte à poussière analogue à celle qui est représentée à la Figure 40, dans laquelle un courant d'air maintient en suspension de la poudre de talc. L'enceinte doit contenir 2 kg de poudre par mètre cube de son volume. La poudre de talc utilisée doit être capable d'être passée par un tamis à mailles carrées, construit en fil de 50 µm de diamètre nominal avec une distance nominale libre entre fils de 75 µm. Elle ne doit pas être utilisée pour plus de 20 essais.

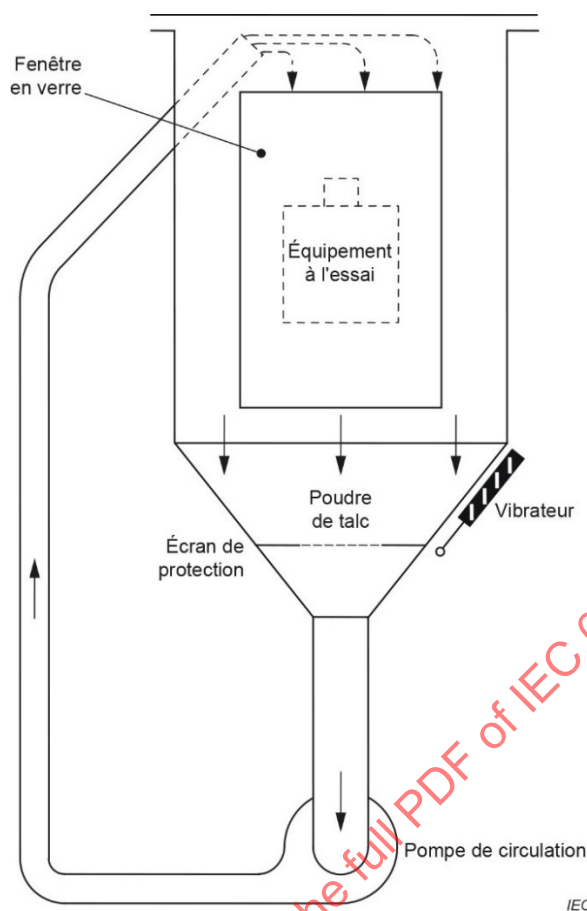

Figure 40 – Appareil pour la vérification de la protection contre les poussières

L'essai doit être effectué de la manière suivante.

- Le luminaire est suspendu à l'extérieur de l'enceinte à poussière et mis en fonctionnement sous sa tension d'alimentation assignée jusqu'à ce que la température de fonctionnement soit atteinte.
- Le luminaire, toujours en fonctionnement, est placé avec le minimum de perturbation dans l'enceinte à poussière.
- La porte de l'enceinte à poussière est fermée.
- Le ventilateur ou le souffleur qui maintient la poudre de talc en suspension est mis en service.
- Après 1 min, le luminaire est éteint et laissé à refroidir pendant 3 h durant lesquelles la poudre de talc est maintenue en suspension.

NOTE L'intervalle de 1 min entre la mise en service du ventilateur ou du souffleur et l'extinction du luminaire a pour but d'assurer une suspension adéquate de la poudre de talc autour du luminaire au début du refroidissement, ce qui est très important pour les luminaires plus petits. Le fonctionnement initial du luminaire est assuré selon le point a) afin d'éviter la surchauffe de l'enceinte d'essai.

11.2.4 Luminaires protégés contre les chutes d'eau verticales – Essais pour le deuxième chiffre 1 de la caractéristique IP

Les luminaires protégés contre les chutes d'eau verticales (deuxième chiffre 1 de la caractéristique IP) sont soumis pendant 10 min à une pluie artificielle de $1^{+0,5}_0$ mm/min, qui tombe verticalement d'une hauteur de 200 mm sur le dessus du luminaire.

11.2.5 Luminaires protégés contre les chutes d'eau verticales – Essais pour le deuxième chiffre 2 de la caractéristique IP

Les luminaires protégés contre les chutes d'eau verticales (deuxième chiffre 2 de la caractéristique IP) sont soumis pendant 10 min à une pluie artificielle de $3^{+0,5}_0$ mm/min, qui tombe verticalement d'une hauteur de 200 mm sur le dessus du luminaire, lorsque le luminaire se trouve dans la position la plus défavorable et incliné jusqu'à 15° de part et d'autre de la verticale.

11.2.6 Luminaires protégés contre la pluie – Essais pour le deuxième chiffre 3 de la caractéristique IP

Les luminaires protégés contre la pluie (deuxième chiffre 3 de la caractéristique IP) reçoivent pendant 10 min un arrosage au moyen de l'appareil pulvérisateur comme cela est représenté à la Figure 41. Le rayon du tube semi-circulaire doit être aussi petit que possible et compatible avec la taille et la position du luminaire.

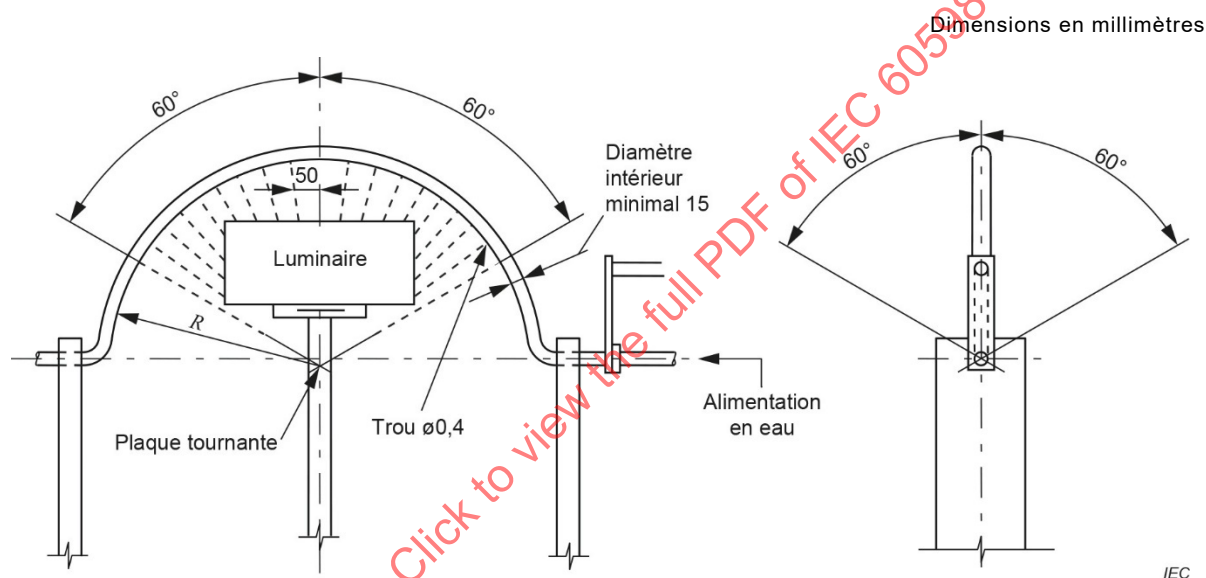

	Luminaire protégé contre	
	Protégé contre la pluie	Protégé contre les projections d'eau
Demi-angle d'oscillation	±60°	±180°
Trous à l'intérieur du demi-angle	±60°	±90°

Figure 41 – Appareil pour la vérification de la protection contre la pluie et les projections d'eau

Le tube doit être perforé de manière que les jets d'eau soient dirigés vers le centre du cercle; le débit de l'eau à l'entrée de la buse doit être approximativement de 0,07 l/min avec une tolérance de ±5 % par trou multiplié par le nombre de trous (approximativement 80 kN/m²).

Le tube doit être amené à osciller sur un angle de 120°, soit de 60° de part et d'autre de la verticale, la durée d'une oscillation complète (2 × 120°) étant d'environ 4 s.

Le luminaire doit être monté au-dessus de l'axe de pivotement du tube, de façon que les extrémités du luminaire reçoivent un recouvrement adéquat provenant des jets. Le luminaire doit pivoter autour de son axe vertical, au cours de l'essai, à une vitesse de 1 r/min.

Après cette période de 10 min, le luminaire doit être éteint et mis à refroidir naturellement, tandis que l'aspersion d'eau est poursuivie pendant encore 10 min de plus.

NOTE Au Japon, l'essai au tube oscillant et l'essai au jet spécifiés dans l'IEC 60529 sont acceptés.

11.2.7 Luminaires protégés contre les projections d'eau – Essais pour le deuxième chiffre 4 de la caractéristique IP

Les luminaires protégés contre les projections d'eau (deuxième chiffre 4 de la caractéristique IP) reçoivent pendant 10 min un arrosage depuis toutes les directions au moyen de l'appareil pulvérisateur comme cela est représenté à la Figure 41 et décrit en 11.2.7. Le luminaire doit être monté au centre de l'axe de pivotement du tube, de façon que les extrémités du luminaire reçoivent un recouvrement adéquat des jets.

Le tube doit être amené à osciller sur un angle de presque 360°, soit 180° de part et d'autre de la verticale, la durée d'une oscillation complète ($2 \times 360^\circ$) étant d'environ 12 s. Le luminaire doit pivoter autour de son axe vertical, au cours de l'essai, à une vitesse de 1 r/min.

Le support de l'équipement à l'essai doit être en forme de grillage pour éviter qu'il n'agisse comme déflecteur. Après cette période de 10 min, le luminaire doit être éteint et mis à refroidir naturellement, tandis que l'aspersion d'eau est poursuivie pendant encore 10 min de plus.

NOTE Au Japon, l'essai au tube oscillant et l'essai au jet spécifiés dans l'IEC 60529 sont acceptés.

11.2.8 Luminaires protégés contre les jets d'eau – Essais pour le deuxième chiffre 5 de la caractéristique IP

Les luminaires protégés contre les jets d'eau (deuxième chiffre 5 de la caractéristique IP) sont éteints et immédiatement soumis depuis toutes les directions à un jet d'eau pendant 15 min, au moyen d'un tuyau équipé d'une buse dont les dimensions et la forme sont représentées à la Figure 42. La buse doit être tenue à 3 m de l'échantillon.

Dimensions en millimètres

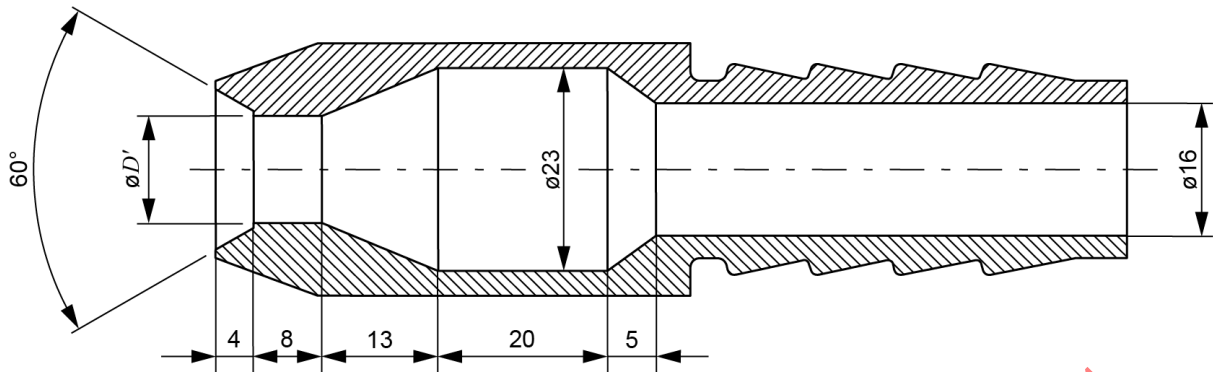

$D' = 6,3$ mm pour l'essai du 11.2.8 (deuxième chiffre caractéristique 5)
 $D' = 12,5$ mm pour l'essai du 11.2.9 (deuxième chiffre caractéristique 6)

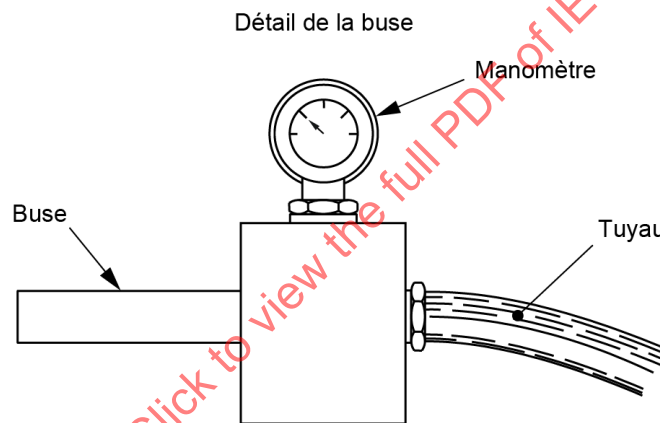

IEC

Figure 42 – Buse pour essai de pluie fine

La pression de l'eau à la buse doit être réglée pour obtenir un débit de 12,5 l/min avec une tolérance de ± 5 % (approximativement 30 kN/mm²).

11.2.9 Luminaires protégés contre les jets d'eau puissants – Essais pour le deuxième chiffre 6 de la caractéristique IP

Les luminaires protégés contre les jets d'eau (deuxième chiffre 6 de la caractéristique IP) sont éteints et immédiatement soumis depuis toutes les directions à un jet d'eau pendant 3 min, au moyen d'un tuyau équipé d'une buse dont les dimensions et la forme sont représentées à la Figure 42. La buse doit être tenue à 3 m de l'échantillon.

La pression de l'eau à la buse doit être réglée pour obtenir un débit de 100 l/min avec une tolérance de ± 5 % (approximativement 100 kN/mm²).

11.2.10 Luminaires étanches à l'immersion – Essais pour le deuxième chiffre 7 de la caractéristique IP

Les luminaires étanches à l'immersion (deuxième chiffre 7 de la caractéristique IP) sont éteints et immédiatement immergés dans l'eau pendant 30 min, de manière qu'il y ait au moins 150 mm d'eau au-dessus du sommet du luminaire et que sa partie la plus basse soit située au moins à 1 m sous l'eau. Les luminaires doivent être maintenus en position par leurs moyens de fixation normaux. Les luminaires pour lampes tubulaires à fluorescence doivent être positionnés horizontalement, leurs diffuseurs tournés vers le haut, à 1 m sous la surface de l'eau.

NOTE Ce procédé n'est pas suffisamment sévère pour les luminaires destinés à fonctionner sous l'eau.

11.2.11 Luminaires étanches à l'immersion sous pression – Essais pour le deuxième chiffre 8 de la caractéristique IP

Les luminaires étanches à l'immersion sous pression (deuxième chiffre 8 de la caractéristique IP) sont chauffés en allumant la lampe ou par tout autre moyen convenable, de sorte que la température de l'enveloppe du luminaire dépasse celle de l'eau dans le réservoir d'essai de 5 °C à 10 °C.

Le luminaire doit ensuite être éteint et soumis à une pression d'eau égale à 1,3 fois la pression qui correspond à la profondeur d'immersion assignée maximale pendant une période de 30 min.

11.2.12 Luminaires protégés contre les jets d'eau à haute pression et haute température – Essais pour le deuxième chiffre 9 (80 °C) de la caractéristique IP

Les luminaires protégés contre les jets d'eau à haute pression et haute température (deuxième chiffre 9 (80 °C) de la caractéristique IP) sont éteints et immédiatement soumis à un jet d'eau à haute pression et haute température. L'essai est effectué en pulvérisant sur le luminaire un jet d'eau chaude avec une buse d'essai normalisée comme cela est décrit dans l'IEC 60529. L'eau employée pour les essais doit être à une température de (80 ± 5) °C. Pour les petites enveloppes (plus grande dimension inférieure à 250 mm), la durée totale de l'essai est de 2 min. Pour les grandes enveloppes (plus grande dimension supérieure ou égale à 250 mm), la durée de l'essai est égale à 1 min/m^2 de surface calculée de l'enveloppe (à l'exclusion de toute surface de montage), la durée minimale étant de 3 min.

11.2.13 Luminaires protégés contre les jets d'eau froide à haute pression – Essais pour le deuxième chiffre 9 (15 °C) de la caractéristique IP

Les luminaires protégés contre les jets d'eau froide à haute pression (deuxième chiffre 9 (15 °C) de la caractéristique IP) sont éteints et immédiatement soumis à un jet d'eau froide à haute pression. L'essai est effectué en pulvérisant sur le luminaire un jet d'eau à l'aide d'une buse d'essai normalisée comme cela est décrit dans l'IEC 60529. L'eau employée pour les essais doit être à une température de (15 ± 10) °C. Pour les petites enveloppes (plus grande dimension inférieure à 250 mm), la durée totale de l'essai est de 2 min. Pour les grandes enveloppes (plus grande dimension supérieure ou égale à 250 mm), la durée de l'essai est égale à 1 min/m^2 de surface calculée de l'enveloppe (à l'exclusion de toute surface de montage), la durée minimale étant de 3 min.

11.3 Essai d'humidité

11.3.1 Tous les luminaires doivent être protégés contre l'humidité lorsque les conditions d'humidité peuvent survenir en utilisation normale.

La conformité est vérifiée par le traitement d'humidité décrit en 11.3.2, suivi immédiatement des essais de l'Article 12.

Les entrées de câble, si elles existent, doivent être laissées ouvertes; s'il existe des entrées défonçables, l'une d'entre elles doit être ouverte.

Les pièces qui peuvent être retirées à la main (par exemple les composants électriques, les vasques, les glaces de protection) doivent être retirées et soumises, si nécessaire, au traitement d'humidité avec la partie principale.

11.3.2 *Le luminaire est placé dans la position d'utilisation normale la plus défavorable, dans une enceinte humide contenant de l'air dont l'humidité relative est maintenue entre 91 % et 95 %. La température de l'air en tout endroit où peuvent se trouver les échantillons doit être maintenue à 1 °C près de toute valeur "t" convenable entre 20 °C et 30 °C.*

Avant d'être placé dans l'enceinte humide, l'échantillon doit être porté à une température comprise entre "t" et (t + 4) °C. L'échantillon doit demeurer dans l'enceinte pendant 48 h.

NOTE Dans la plupart des cas, l'échantillon peut être porté à la température spécifiée entre "t" et (t + 4) °C en le conservant dans une chambre à cette température pendant au moins 4 h avant de procéder à l'essai d'humidité.

Pour réaliser à l'intérieur de l'enceinte d'essai les conditions spécifiées, il est nécessaire d'assurer une circulation constante de l'air dans celle-ci et, en général, d'utiliser une enceinte thermiquement isolée.

Après ce traitement, l'échantillon ne doit présenter aucune détérioration compromettant la conformité aux exigences du présent document.

12 Résistance d'isolement, rigidité diélectrique, courant de contact et courant dans le conducteur de protection

12.1 Généralités

L'Article 12 spécifie les exigences et les essais pour la résistance d'isolement, la rigidité diélectrique, le courant de contact et le courant dans le conducteur de protection des luminaires.

12.2 Résistance d'isolement et rigidité diélectrique

12.2.1 Généralités

La résistance d'isolement et la rigidité diélectrique des luminaires doivent être adéquates.

La conformité est vérifiée par les essais des 12.2.2 et 12.2.3 exécutés dans l'enceinte humide ou dans la chambre où l'échantillon a été porté à la température spécifiée, après remise en place des parties qui ont pu être éventuellement retirées.

S'il existe un interrupteur, il doit être placé, pour tous les essais, dans la position "fermée", sauf pour les essais entre les parties actives qui peuvent être séparées par la manœuvre d'un interrupteur.

Pendant ces essais, les composants suivants doivent être débranchés, afin que les tensions d'essai soient appliquées à l'isolation de ces composants et non pas à leurs éléments fonctionnels inductifs ou capacitifs, selon le cas:

- a) les condensateurs reliés par un shunt;*
- b) les condensateurs montés entre les parties actives et le corps;*
- c) l'impédance de protection;*
- d) les inductances ou transformateurs montés entre des parties actives;*
- e) les dispositifs de protection contre les surtensions conformément au 7.32.*

S'il n'est pas possible d'appliquer une feuille métallique sur les revêtements ou les cloisons, les essais doivent être effectués sur trois parties du revêtement ou de la cloison qui ont été prélevées puis placées entre deux billes métalliques de 20 mm de diamètre, pressées l'une contre l'autre avec une force de $2\text{ N} \pm 0,5\text{ N}$.

Les conditions d'essai pour les appareillages de commande doivent être celles spécifiées dans la série IEC 61347.

L'isolation entre les parties actives et le corps, ainsi qu'entre les parties métalliques accessibles et la feuille métallique à l'intérieur des revêtements et des cloisons, est soumise à l'essai selon le type d'isolation exigé.

NOTE Le terme "corps" inclut les parties métalliques accessibles, les vis de fixation accessibles et la feuille métallique en contact avec les parties accessibles des matériaux isolants.

Lors de la réalisation de l'essai de rigidité diélectrique des luminaires qui contiennent un appareillage de commande électronique, des tensions assignées du circuit lampe plus importantes que la tension assignée d'alimentation du luminaire peuvent survenir. Celles-ci sont indiquées par la valeur assignée U_{out} marquée sur l'appareillage de commande. Dans ce cas, les tensions d'essai appliquées aux parties du circuit lampe doivent être calculées à partir de la valeur assignée U_{out} au lieu de U , où U est la tension de service.

12.2.2 Essai – Résistance d'isolement

La résistance d'isolement doit être mesurée sous une tension continue de 500 V environ, 1 min après l'application de cette tension.

Pour l'isolation des parties des luminaires en TBTS ou TBTP, la tension à utiliser pour les mesurages est de 100 V en courant continu.

La résistance d'isolement ne doit pas être inférieure aux valeurs indiquées dans le Tableau 15.

L'isolation entre parties actives dangereuses et le corps des luminaires de classe II ne doit pas être soumise à l'essai si l'isolation principale et l'isolation supplémentaire peuvent être soumises à l'essai séparément.

Tableau 15 – Résistance d'isolement minimale

Isolation des parties	Valeur minimale de la résistance d'isolement		
	MΩ		
	Luminaires de classe I	Luminaires de classe II	Luminaires de classe III
TBTS/TBTP:			
Entre parties conductrices de polarités différentes	A	A	A
Entre parties conductrices et la surface de montage ^a	A	A	A
Entre parties conductrices et parties métalliques du luminaire ^c	A	A	A
Entre les surfaces externes d'un câble ou cordon souple lorsqu'il est retenu dans un dispositif d'arrêt de traction et les parties métalliques accessibles	A	A	A
Traversées de câble isolantes comme cela est décrit à l'Article 8	A	A	A
Autres que TBTS/TBTP:			
Entre parties actives dangereuses de polarités différentes	B	B	-
Entre parties actives dangereuses et la surface de montage ^a	B	B et C, ou D	-
Entre parties actives dangereuses et parties métalliques du luminaire	B	B et C, ou D	-
Entre les parties actives dangereuses qui peuvent devenir de différentes polarités par la manœuvre d'un interrupteur	B ^b	B ^b	-
Entre les surfaces externes d'un câble ou cordon souple lorsqu'il est retenu dans un dispositif d'arrêt de traction et les parties métalliques accessibles	B	C	-
Traversées de câble isolantes comme cela est décrit à l'Article 8	B	C	-
A Isolation principale pour les tensions TBTS/TBTP	1		
B Isolation principale pour les tensions autres que TBTS/TBTP	2		
C Isolation supplémentaire	2		
D Double isolation ou isolation renforcée	4		
^a La surface de montage est recouverte d'une feuille métallique pour les besoins du présent essai. ^b Durant l'essai, l'interrupteur peut influencer le résultat. Dans le cas de déconnexion électronique conformément à l'IEC 61058-1:2016, 7.14.1, ou de microdéconnexion conformément à l'IEC 61058-1:2016, 7.14.2, il peut s'avérer nécessaire d'enlever l'interrupteur du circuit. ^c Cette exigence n'exclut pas la mise à la terre des circuits TBTP à des fins fonctionnelles.			

Les cloisons et revêtements isolants ne doivent être soumis à l'essai que si la distance entre les parties actives et les parties métalliques accessibles, en l'absence de la cloison ou du revêtement, est inférieure à celle spécifiée à l'Article 13.

L'isolation des traversées, des dispositifs d'arrêt de traction, des cavaliers ou des pinces doit être soumise à l'essai selon le Tableau 15 et, pendant l'essai, le câble ou cordon doit être recouvert d'une feuille métallique ou remplacé par une tige métallique de même diamètre.

Le 12.2.2 ne s'applique pas aux dispositifs d'amorçage raccordés spécialement au réseau s'ils ne sont pas des parties actives dangereuses.

NOTE Voir l'Annexe A pour un essai qui concerne les parties actives dangereuses.

12.2.3 Essai – Rigidité diélectrique

Une tension pratiquement sinusoïdale, de fréquence 50 Hz ou 60 Hz, dont la valeur est indiquée dans le Tableau 16, doit être appliquée pendant 1 min aux isolations désignées dans ce tableau.

Au début de l'essai, la tension appliquée ne doit pas dépasser la moitié de la valeur spécifiée, puis elle est relevée progressivement jusqu'à la valeur visée.

Dans le cas d'un luminaire dans lequel il est impossible de retirer les condensateurs de couplage, ce qui conduit à un résultat incorrect lors de l'essai en courant alternatif, un autre essai de rigidité diélectrique avec une tension d'essai continue peut être appliqué selon la procédure d'essai suivante:

- *la tension d'essai continue doit être pratiquement lisse. Cette exigence est respectée si les valeurs de crête absolues de la tension ne s'écartent pas de la valeur moyenne absolue de plus de 3 %. La valeur moyenne de la tension d'essai continue doit être égale à la valeur de crête de la tension d'essai alternative, comme cela est spécifié dans le Tableau 16;*
- *la tension d'essai continue doit être augmentée progressivement de 0 V jusqu'à la valeur spécifiée ci-dessus en 5 s et maintenue à cette valeur pendant 1 min.*

Pour la source haute tension utilisée pour l'essai, lorsque les bornes de sortie sont court-circuitées, après que la tension de sortie a été réglée à la valeur de la tension d'essai appropriée, le courant de sortie doit être d'au moins 200 mA.

Le relais de surintensité ne doit pas se déclencher lorsque le courant de sortie est inférieur à 100 mA.

La valeur de la tension d'essai appliquée doit être à ± 3 %.

La feuille métallique doit être placée de telle manière qu'il ne se produise pas de contournements sur les bords de l'isolation.

Pour les luminaires de classe II comportant à la fois une isolation renforcée et une double isolation, la tension appliquée à l'isolation renforcée ne doit pas surcharger l'isolation principale ou l'isolation supplémentaire.

Des effluves sans chute de tension ne sont pas pris en compte.

Pendant l'essai, il ne doit se produire ni contournement ni perforation.

Ces exigences ne s'appliquent pas aux dispositifs d'amorçage raccordés spécialement au réseau s'ils ne sont pas des parties actives dangereuses.

Pour les luminaires avec amorceurs, la rigidité diélectrique des parties du luminaire soumises aux contraintes de la tension d'impulsion est vérifiée par l'essai avec l'amorceur en fonctionnement, afin d'assurer que l'isolation du luminaire, du câblage et des parties similaires est satisfaisante.

Pour les luminaires avec amorceurs et douilles qui, selon les instructions du fabricant de douilles, atteignent seulement leur protection maximale à l'impulsion de tension avec une lampe insérée, une lampe factice doit être insérée pour le présent essai.

NOTE 1 La lampe factice peut être fournie avec l'échantillon d'essai de type.

NOTE 2 La présente exigence permet à la conception du culot/douille de conserver une taille raisonnable tout en autorisant la tension d'impulsion à augmenter jusqu'à un niveau qui assure le redémarrage à chaud d'une lampe à décharge (par exemple dans des applications studio).

Le luminaire avec amorceurs est connecté à une alimentation de tension égale à 100 % de la tension assignée, pendant une période de 24 h. Si des amorceurs présentent une défaillance pendant cette période, ils sont immédiatement remplacés. L'essai de rigidité diélectrique selon les valeurs spécifiées dans le Tableau 16 est alors appliqué au luminaire avec toutes les bornes (sauf la borne de terre) de l'amorceur connectées ensemble.

Pour les luminaires avec amorceurs manuels tels que les boutons-poussoirs, le luminaire est connecté à une alimentation égale à 100 % de la tension assignée et soumis à un cycle de "3 s allumé/10 s éteint" pendant une période complète de 1 h. Un seul amorceur est utilisé pour cet essai.

Les luminaires avec amorceurs fournis avec des ballasts qui comportent un marquage pour l'utilisation exclusive avec un amorceur équipé d'un appareil de limitation de la durée de fonctionnement, conforme à l'IEC 61347-2-9, doivent être soumis au même essai, mais pendant une durée de 250 cycles allumage/extinction, tout en conservant une période d'extinction de 2 min.

Pendant l'essai, il ne doit se produire ni contournement ni perforation.

Lors de la réalisation de l'essai de rigidité diélectrique des luminaires qui contiennent un appareillage de commande électronique, des tensions assignées du circuit lampe plus importantes que la tension assignée d'alimentation du luminaire peuvent survenir. Celles-ci sont indiquées par la valeur assignée U_{out} marquée sur l'appareillage de commande. Dans ce cas, les tensions d'essai appliquées aux parties du circuit lampe doivent être calculées à partir de la valeur assignée U_{out} marquée sur l'appareillage de commande au lieu de U , où U est la tension de service.

De plus, selon le type d'isolation entre le réseau d'alimentation et les circuits de sortie de l'appareillage de commande, la valeur de la tension de service U utilisée pour l'essai électrique doit être fondée sur U_{out} sur le réseau d'alimentation ou sur U_{out} plus le réseau d'alimentation, comme cela est décrit dans le Tableau T.1.

Tableau 16 – Rigidité diélectrique

Isolation des parties	Tension d'essai V		
	Luminaires de classe I	Luminaires de classe II	Luminaires de classe III
TBTS/TBTP:			
Entre parties conductrices de polarités différentes	A	A	A
Entre parties conductrices et la surface de montage ^a	A	A	A
Entre parties conductrices et parties métalliques du luminaire ^d	A	A	A
Entre les surfaces externes d'un câble ou cordon souple lorsqu'il est retenu dans un dispositif d'arrêt de traction et les parties métalliques accessibles	A	A	A

Isolation des parties	Tension d'essai V		
	Luminaires de classe I	Luminaires de classe II	Luminaires de classe III
Traversées de câble isolantes comme cela est décrit à l'Article 8	A	A	A
Autres que TBTS/TBTP:			
Entre parties actives dangereuses de polarités différentes	B	B	-
Entre parties actives dangereuses et la surface de montage ^a	B	B et C, ou D ^e	-
Entre parties actives dangereuses et parties métalliques du luminaire	B	B et C, ou D ^e	-
Entre les parties actives dangereuses qui peuvent devenir de différentes polarités par la manœuvre d'un interrupteur	B ^c	B ^c	-
Entre les surfaces externes d'un câble ou cordon souple lorsqu'il est retenu dans un dispositif d'arrêt de traction et les parties métalliques accessibles	B	C	-
Traversées de câble isolantes comme cela est décrit à l'Article 8	B	C	-
A Isolation principale pour les tensions TBTS/TBTP	500		
B Isolation principale pour les tensions autres que TBTS/TBTP	$2U^b + 1\ 000$		
C Isolation supplémentaire	$2U^b + 1\ 000$		
D Double isolation ou isolation renforcée	$4U^b + 2\ 000$		
<p>^a La surface de montage est recouverte d'une feuille métallique pour les besoins du présent essai.</p> <p>^b U dans ce cas désigne la tension phase-neutre nominale du système d'alimentation neutre-terre. Des conseils peuvent être obtenus dans l'IEC 60664-1.</p> <p>^c Durant l'essai, l'interrupteur peut influencer le résultat. Dans le cas de déconnexion électronique conformément à l'IEC 61058-1:2016, 7.14.1, ou de microdéconnexion conformément à l'IEC 61058-1:2016, 7.14.2, il peut s'avérer nécessaire d'enlever l'interrupteur du circuit.</p> <p>^d Cette exigence n'exclut pas la mise à la terre des circuits TBTP à des fins fonctionnelles.</p> <p>^e Ce tableau donne les détails dans les cas où aucune isolation électrique n'est prévue entre le réseau d'alimentation et les circuits de sortie de l'appareillage de commande. Lorsque l'appareillage de commande assure l'isolation principale, la double isolation ou l'isolation renforcée du réseau d'alimentation, l'isolation exigée entre la partie active dangereuse et la partie accessible, y compris la surface de montage, peut être différente. En raison des exigences selon le Tableau T.1, la tension d'essai peut être modifiée.</p>			

12.3 Courant de contact, courant dans le conducteur de protection et brûlure électrique

Le courant de contact ou le courant dans le conducteur de protection qui peut se produire pendant un fonctionnement normal du luminaire ne doit pas dépasser les valeurs du Tableau 17 lorsqu'il est mesuré selon l'Annexe G.

Tableau 17 – Limites des courants de contact ou des courants dans le conducteur de protection et brûlure électrique

Courant de contact, courant dans le conducteur de protection et brûlure électrique		Limites maximales
Courant de contact		
Type de luminaire	Courants d'alimentation	
Luminaires de classe II	tous	0,7 mA (valeur de crête)
Luminaires de classe I jusqu'à 16 A assignés inclus équipés d'une fiche pouvant se connecter à un socle de prise de courant sans mise à la terre ^a	tous	0,7 mA (valeur de crête)
Parties métalliques des luminaires de classe I isolées par double isolation ou isolation renforcée	tous	0,7 mA (valeur de crête)
Courant dans le conducteur de protection		
Type de luminaire	Courants d'alimentation	
Luminaires de classe I équipés d'une fiche simple ou multiphase jusqu'à 32 A inclus	≤ 4 A	2 mA (valeur efficace)
	>4 A, mais ≤ 10 A	0,5 mA/A (valeur efficace)
	> 10 A	5 mA (valeur efficace)
Luminaires de classe I destinés à être connectés de façon permanente	≤ 7 A	3,5 mA (valeur efficace)
	>7 A, mais ≤ 20 A	0,5 mA/A (valeur efficace)
	> 20 A	10 mA (valeur efficace) ou selon les instructions du fabricant
Brûlure électrique		
Type de luminaire	Courants d'alimentation	
Tous les types de luminaires	tous	u.c.
NOTE L'Australie et la Nouvelle-Zélande n'admettent aucun courant dans le conducteur de protection supérieur à 10 mA.		
^a L'essai n'est pas exigé lorsque les instructions du fabricant fournies avec le luminaire conseillent que le luminaire doit être mis à la terre.		

La conformité est vérifiée selon l'Annexe G.

NOTE 1 Pour les luminaires incorporant des appareillages de commande électroniques alimentés en courant alternatif, le courant de fuite peut être fortement dépendant de l'espace entre la lampe et le dispositif d'amorçage relié à la terre, compte tenu du fonctionnement de la lampe en haute fréquence.

NOTE 2 D'autres explications en ce qui concerne le mesurage du courant de contact et du courant dans le circuit de protection peuvent être consultées dans l'IEC 60990.

13 Lignes de fuite et distances dans l'air

13.1 Généralités

L'Article 13 spécifie les exigences minimales applicables aux lignes de fuite et aux distances dans l'air des luminaires.

NOTE 1 La façon dont les lignes de fuite et les distances dans l'air sont mesurées est spécifiée dans l'IEC 60664-1.

NOTE 2 La méthode de calcul et la structure des lignes de fuite et des distances dans l'air sont tirées de l'IEC 60664-1:2020 et de l'IEC 60664-4.

NOTE 3 L'Annexe Q donne des informations relatives aux valeurs de la catégorie de surtension III.

13.2 Exigences

13.2.1 Généralités

Les parties spécifiées dans le Tableau K.1 doivent être espacées de manière adéquate. Les lignes de fuite et les distances dans l'air ne doivent pas être inférieures aux valeurs indiquées dans le Tableau 18, le Tableau 19 et le Tableau 20. Les lignes de fuite ne doivent pas être inférieures aux valeurs minimales exigées de distances dans l'air.

Aucune valeur n'est spécifiée pour des tensions de service inférieures ou égales à 25 V en courant alternatif et 60 V en courant continu, car la tension d'essai du Tableau 16 est considérée comme suffisante.

Les distances entre les parties conductrices de polarités opposées doivent satisfaire aux exigences de l'isolation principale.

Les distances minimales spécifiées reposent sur les paramètres suivants:

- pour une utilisation jusqu'à 2 000 m au-dessus du niveau de la mer;
- le degré de pollution 2 pour lequel normalement seules des pollutions non conductrices interviennent, mais occasionnellement une conductivité temporaire peut apparaître par condensation;
- le matériel de catégorie de surtension II est un équipement utilisateur d'énergie qui doit être alimenté par l'installation fixe.

Pour les détails des degrés de pollution ou des catégories de surtensions, il convient de consulter l'IEC 60664-1.

La conformité est vérifiée par des mesurages effectués avec et sans conducteurs de la plus grande section, reliés aux bornes des luminaires. Les bornes du câblage interne des luminaires doivent être vérifiées avec les conducteurs présents fournis avec le luminaire installé.

La contribution aux lignes de fuite des rainures de moins de 1 mm de largeur est limitée à la largeur de ces rainures.

Une ligne de fuite ou une distance dans l'air peut être divisée en plusieurs parties. Toute fente d'air de moins de 1 mm de largeur n'est pas prise en considération pour le calcul de la distance totale dans l'air sauf si la distance totale est inférieure à 3 mm, auquel cas un tiers de la largeur de la fente d'air doit être pris en compte.

Pour les luminaires équipés d'un socle de connecteur, les mesurages sont effectués après avoir inséré un connecteur approprié.

Les distances à travers les fentes ou ouvertures dans les parties externes des matériaux isolants sont mesurées avec une feuille métallique en contact avec la surface accessible. La feuille est poussée dans les coins et endroits similaires à l'aide du doigt d'épreuve normalisé (calibre d'essai B selon l'IEC 61032:1997, Figure 2), mais elle n'est pas enfoncée dans les ouvertures.

Les réductions des lignes de fuite et des distances dans l'air sont autorisées pour les luminaires qui sont protégés (ou qui sont équipés de parties protégées) contre la pollution par l'utilisation de revêtements ou d'enrobages, si les exigences de l'IEC 61347-1:2015, Annexe P sont respectées.

Les valeurs du Tableau 18 et du Tableau 19 ne s'appliquent pas aux composants pour lesquels des publications IEC spécifiques existent, cependant elles s'appliquent aux distances de montage et d'accessibilité du composant lorsqu'il est intégré au luminaire.

Les lignes de fuite à une borne d'alimentation doivent être mesurées depuis la partie active de la borne jusqu'aux parties métalliques accessibles, et la distance dans l'air doit être mesurée entre le câblage d'alimentation entrant et les parties métalliques accessibles, c'est-à-dire du conducteur nu de la section la plus grande aux parties métalliques qui peuvent être accessibles. Si la longueur de l'isolation à retirer du câblage d'alimentation par l'installateur est spécifiée dans les instructions de montage du luminaire, cette longueur d'isolation doit être retirée pour l'essai. Dans tous les cas, le conducteur dénudé doit être d'au moins 8 mm, même si une distance inférieure est spécifiée par le fabricant. Pendant l'essai, les conducteurs doivent être placés au centre des bornes, comme cela est représenté à la Figure 43. Du côté du câblage interne de la borne, la distance dans l'air doit être mesurée entre les parties actives de la borne et les parties métalliques accessibles (voir Figure 43).

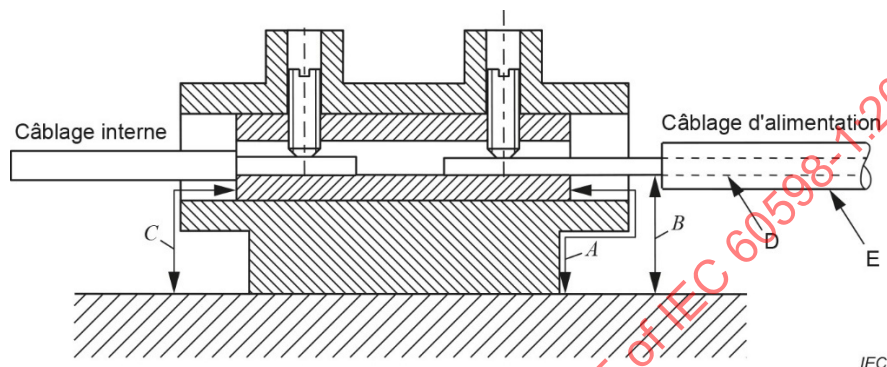

Légende

- A ligne de fuite
- B distance dans l'air (câblage d'alimentation)
- C distance dans l'air (câblage interne)
- D conducteur
- E isolant

Figure 43 – Représentation des mesurages des lignes de fuite et distances dans l'air au niveau d'une borne d'alimentation

NOTE Les mesurages des distances dans l'air à partir du câblage d'alimentation et du câblage interne peut différer parce que le fabricant du luminaire n'a pas la maîtrise de la longueur de l'isolation du câblage d'alimentation laissée par l'installateur. Toutefois, il peut être attendu de l'installateur qu'il respecte les instructions du fabricant du luminaire.

Lorsque les lignes de fuite et distances dans l'air sont évaluées sur les traversées, les dispositifs d'arrêt de traction, les cavaliers ou les pinces, les mesurages doivent être réalisés avec le câble installé.

13.2.2 Lignes de fuite

Les valeurs minimales des lignes de fuite sont énumérées dans le Tableau 18.

Pour les dimensions des lignes de fuite, les valeurs efficaces de la tension de service doivent être prises en compte. Dans le cas d'un circuit isolé, les exigences du 7.31 et de l'Annexe T doivent être prises en compte afin de déterminer la tension de service.

Les valeurs du Tableau 18 sont valides pour les tensions dont la fréquence est inférieure à 30 kHz. Pour des fréquences plus élevées, les exigences suivantes doivent s'appliquer.

- Si la combinaison de tension et de fréquence exige des valeurs plus élevées de lignes de fuite, les informations fournies par le fabricant de l'appareillage doivent être utilisées (voir note de bas de tableau "b" du Tableau 18).

- Si le luminaire intègre ou est utilisé en combinaison avec des composants ou des dispositifs autres que l'appareillage couvert par la série IEC 61347 et produisant une fréquence supérieure à 30 kHz, les exigences de l'IEC 60664-4 doivent s'appliquer.

Tableau 18 – Lignes de fuite minimales pour tensions sinusoïdales en courant alternatif jusqu'à 30 kHz (à utiliser conjointement avec l'Annexe K)

Tension de service ^a V	Ligne de fuite minimale ^b mm			
	Isolation principale ou supplémentaire		Isolation renforcée	
	ITC < 600	ITC ≥ 600	ITC < 600	ITC ≥ 600
25	0,5	0,5	– ^c	– ^c
50	1,2	0,6	– ^c	– ^c
150	1,6	0,8	3,2	1,6
250	2,5	1,25	5,0	2,5
500	5,0	2,5	10	5,0
750	7,5	3,75	16	7,5
1 000	10	5,0	20	10
1 500	15	7,5	30	15

L'interpolation linéaire entre les lignes est admise.

NOTE 1 Indice de tenue au cheminement (ITC) conformément à l'IEC 60112.

NOTE 2 Les valeurs reposent sur le Tableau F 5 (degré de pollution 2, groupes de matériaux I et III) de l'IEC 60664-1:2020.

^a Pour les lignes de fuite, la tension équivalente en courant continu est égale à la valeur efficace de la tension sinusoïdale en courant alternatif.

^b Dans le cas d'une combinaison de tension et de fréquence qui exige des valeurs de lignes de fuite supérieures à celles exigées dans ce tableau, le marquage de l'appareillage indique les détails de cette combinaison (tension de sortie de crête maximale de service \hat{U}_{out} et fréquence $f_{U_{out}}$) – voir l'IEC 61347-1:2015, 7.1, point w). Pour les détails et les valeurs exigées pour les lignes de fuite, voir l'IEC 61347-1:2015, 16.2.3.

^c Valeurs à l'étude.

Dans le cas des lignes de fuite aux parties qui ne sont pas sous tension et qui ne sont pas prévues pour être raccordées à la terre, où le cheminement ne peut se produire, les valeurs spécifiées pour les matériaux à IRC ≥ 600 doivent s'appliquer à tous les matériaux (indépendamment de l'IRC réel).

Pour les lignes de fuite soumises à des tensions de service d'une durée inférieure à 60 s, les valeurs spécifiées pour les matériaux à IRC ≥ 600 doivent s'appliquer à tous les matériaux.

Pour les lignes de fuite non sujettes à contamination par les poussières ou l'humidité, ce qui peut être réalisé par revêtement ou enrobage, les valeurs spécifiées pour les matériaux à IRC ≥ 600 doivent s'appliquer (indépendamment de l'IRC réel).

13.2.3 Distances dans l'air

Les valeurs minimales des distances dans l'air sont énumérées dans le Tableau 19 et le Tableau 20. Le Tableau 19 doit être appliqué à tous les circuits qui prennent en compte les transitoires qui viennent du réseau d'alimentation. Le Tableau 20 est applicable aux circuits dans lesquels les tensions de crête sont générées par l'équipement (en interne ou en externe).

Les valeurs du Tableau 19 et du Tableau 20 sont valides pour les tensions dont la fréquence est inférieure à 30 kHz. Pour des fréquences plus élevées, les exigences suivantes doivent s'appliquer:

- si la combinaison de tension et de fréquence exige des valeurs plus élevées de distances dans l'air que celles du Tableau 19 et du Tableau 20, la tension de crête transformée équivalente (U_p) fournie par le fabricant de l'appareillage doit être utilisée. La valeur de U_p est directement comparable aux valeurs indiquées dans le Tableau 20. La valeur de U_p peut être différente pour l'évaluation de l'isolation principale/supplémentaire et renforcée;
- si le luminaire intègre ou est utilisé en combinaison avec des composants ou des dispositifs autres que l'appareillage couvert par la série IEC 61347 et produisant une fréquence supérieure à 30 kHz, les exigences de l'IEC 60664-4 doivent s'appliquer.

Tableau 19 – Distances dans l'air minimales pour tensions de service (à utiliser conjointement avec l'Annexe K)

Distances mm	Tension de service efficace n'excédant pas				
	50	150	300	600	1 000
Distances dans l'air avec transitoires du réseau d'alimentation selon la catégorie de surtension II ^b					
– Isolation principale ou supplémentaire	0,2	0,5	1,5	3	5,5
– Isolation renforcée	0,2	1,5	3	5,5	8
Distances dans l'air sans transitoires du réseau d'alimentation ^{a b}					
– Isolation principale ou supplémentaire	0,2	0,2	0,2	0,2	0,7
– Isolation renforcée	0,2	0,2	0,2	0,6	1,6
^a Les valeurs de cette ligne sont applicables aux circuits pour lesquels il est assuré qu'ils ne présentent pas de transitoire (par exemple circuits de batterie).					
^b Pour les distances dans l'air, la tension en courant continu équivalente est égale à la tension en courant alternatif de crête. L'interpolation entre les colonnes n'est pas autorisée, si les transitoires selon la catégorie de surtension II doivent être pris en compte pour le réseau d'alimentation.					

Les valeurs minimales de distances dans l'air pour les tensions d'impulsion d'amorçage et les tensions de crête transformées équivalentes (U_p) sont données dans le Tableau 20.

Tableau 20 – Distances minimales pour tensions d'impulsion d'amorçage ou tension de crête transformée équivalente U_p

	Tension d'impulsion d'amorçage assignée ou tension de crête transformée équivalente U_p								
	kV								
	2,0	2,5	3,0	4,0	5,0	6,0	8,0	10	12
Valeurs minimales de distances dans l'air en mm ^a (isolation principale et supplémentaire)	1	1,5	2	3	4	5,5	8	11	14
Valeurs minimales de distances dans l'air en mm ^a (isolation renforcée)	2,2	3,0	3,8	6,0	8,0	10,4	15	19,4	24
	Tension d'impulsion d'amorçage assignée ou tension de crête transformée équivalente U_p								
	kV								
	15	20	25	30	40	50	60	80	100
Distance minimale dans l'air en mm ^a	18	25	33	40	60	75	90	130	170
Valeurs minimales de distances dans l'air en mm ^a (isolation renforcée)	31,4	44	60	72	98	130	162	Aucune donnée disponible	
NOTE Les distances du Tableau 20 sont obtenues à partir de l'IEC 60664-1:2020, Tableau F.2, cas A, conditions de champs hétérogènes.									
^a L'interpolation linéaire entre les colonnes est admise.									

Pour les distances soumises à la tension sinusoïdale ainsi qu'aux impulsions non sinusoïdales, la distance minimale exigée ne doit pas être inférieure à la plus élevée des valeurs indiquées dans le Tableau 18, le Tableau 19 et le Tableau 20.

14 Essai d'endurance et essai d'échauffement

14.1 Généralités

L'Article 14 spécifie les exigences qui concernent l'essai d'endurance et les essais d'échauffement des luminaires.

14.2 Sélection des lampes et appareillages de commande

Les lampes utilisées pour les essais de l'Article 14 doivent être choisies conformément à l'Annexe B.

Les lampes utilisées pour l'essai d'endurance fonctionnent au-dessus de leur puissance assignée pendant de longues périodes et ne doivent pas être employées pour les essais d'échauffement. Cependant, il est d'usage courant de conserver, pour l'essai d'échauffement en fonctionnement anormal, ces lampes déjà utilisées au cours de l'essai d'échauffement en fonctionnement normal.

Si le luminaire nécessite un appareillage de commande distinct et si celui-ci n'est pas fourni avec le luminaire, un appareillage de commande doit être choisi à des fins d'essai, qui représente la production normale et qui correspond à la spécification d'appareillage de commande appropriée. Dans le cas des ballasts pour lampes à décharge, la puissance fournie à une lampe de référence par le ballast sous les conditions de référence doit être à $\pm 3\%$ de la puissance assignée de la lampe. En cas de tension constante ou d'alimentation en courant constant, une alimentation en laboratoire ou un appareillage de commande spécialement préparé, qui délivre le courant spécifié ou la tension spécifiée, peut être utilisé.

NOTE 1 Pour les conditions de référence, voir la norme d'appareillage de commande correspondante de l'IEC.

NOTE 2 Dans les normes correspondantes de performance des lampes, la puissance assignée peut encore être intitulée puissance "visée". Ce terme sera corrigé dans les futures éditions de ces normes.

14.3 Essai d'endurance

14.3.1 Généralités

Dans les conditions représentant l'échauffement et le refroidissement cycliques en service, le luminaire ne doit pas devenir dangereux.

La conformité est vérifiée par la réalisation de l'essai décrit en 14.3.2.

14.3.2 Essai

- a) *Le luminaire doit être disposé dans une étuve avec les moyens de contrôle de la température ambiante dans l'étuve.*

Le luminaire doit être placé sur une surface de montage similaire à celle de l'essai d'échauffement en fonctionnement normal (et dans la même position de fonctionnement, voir 14.4).

- b) *La température ambiante à l'intérieur de l'étuve doit être maintenue pendant la durée de l'essai à $\pm 2\text{ }^{\circ}\text{C}$ de $(t_a + 10)\text{ }^{\circ}\text{C}$; t_a est égale à $25\text{ }^{\circ}\text{C}$ sauf indication contraire sur le luminaire.*

La température ambiante à l'intérieur de l'étuve doit être mesurée conformément à l'Annexe I. Les appareillages de commande destinés à fonctionner en dehors du luminaire doivent être disposés à l'air libre, pas nécessairement dans l'étuve, et doivent être mis en fonctionnement à une température ambiante de $25\text{ }^{\circ}\text{C} \pm 5\text{ }^{\circ}\text{C}$.

- c) *Le luminaire doit être soumis à l'essai dans l'enceinte pendant un temps total de 168 h, composé de sept cycles successifs de 24 h. La tension d'alimentation spécifiée au point d) ci-dessous doit être appliquée au luminaire pendant les premières 21 h et interrompue pendant les 3 h restantes de chaque cycle. La période d'échauffement initiale du luminaire fait partie du premier cycle d'essai.*

Le circuit doit être tel que l'essai soit effectué en fonctionnement normal pour les six premiers cycles et en fonctionnement anormal (voir Annexe C) pour le septième cycle. Pour les luminaires qui contiennent un moteur électrique (un ventilateur, par exemple), la condition anormale qui influence le plus défavorablement les résultats de l'essai doit être choisie.

Pour les luminaires alimentés par le biais d'un câblage de communication informatique, le septième cycle est effectué en condition de surtension comme cela est indiqué au point d) en considérant la surtension comme une condition anormale.

Pour les luminaires pour lesquels il n'y a pas d'essai en fonctionnement anormal selon le 14.5, la durée totale de l'essai doit être de 240 h (c'est-à-dire 10×24 cycles en fonctionnement normal). Pour les luminaires à filament, la durée totale de l'essai de 240 h doit s'appliquer dans tous les cas.

- d) *Pendant les périodes de fonctionnement, la tension d'alimentation pour les luminaires à lampes à filament, autres que TBT, doit être de $1,05 \pm 0,015$ fois la tension à laquelle la puissance assignée de la lampe est obtenue.*

Pendant les périodes de fonctionnement, la tension d'alimentation pour les autres luminaires doit être de $1,10 \pm 0,015$ fois la tension assignée, ou la valeur maximale de la plage de tensions assignée.

Pour les luminaires non équipés d'un appareillage pour le fonctionnement à tension constante ou à courant constant, l'essai doit être effectué à 1,1 fois la tension constante d'entrée assignée ou 1,1 fois le courant constant d'entrée assigné, selon le cas.

Pendant les périodes de fonctionnement, la tension d'alimentation pour les luminaires de classe III alimentés par le biais d'un câblage de communication informatique doit être de:

pour les cycles 1 à 6 (représentant un fonctionnement normal)

– 110 % de la tension d'entrée assignée du luminaire au niveau des bornes d'alimentation pour le cycle 7 (représentant un fonctionnement anormal)

– 130 % de la tension d'entrée assignée du luminaire au niveau des bornes d'alimentation pour les circuits supérieurs à 5 V en courant continu, avec un minimum de 7,5 V en courant continu, et

– 150 % de la tension d'entrée assignée du luminaire au niveau des bornes d'alimentation pour les circuits inférieurs ou égaux à 5 V en courant continu.

- e) *Si le luminaire s'arrête de fonctionner en raison d'une défaillance, ce qui suit doit s'appliquer.*

– Les instructions du 14.4.2, point g) doivent s'appliquer en cas de défaillance possible d'une partie du luminaire (y compris la lampe).

– En cas de fonctionnement d'un appareil de protection thermique pendant les six premiers cycles, l'essai doit être modifié comme suit.

1) Pour les luminaires avec appareils de protection cycliques, le luminaire doit être laissé à refroidir jusqu'à ce que l'appareil se réarme. Pour les luminaires avec appareils de protection thermique à simple action (protecteurs thermiques), l'appareil doit être remplacé.

2) Pour tous les modèles de luminaires, l'essai doit être poursuivi jusqu'à 240 h au total, en réglant le circuit et la température de telle manière que l'appareil de protection soit à la limite du déclenchement. Le luminaire est considéré comme n'ayant pas satisfait à l'essai si un réglage au-dessous des caractéristiques assignées du luminaire est nécessaire pour éviter le déclenchement de l'appareil de protection.

– Si un appareil de protection thermique se déclenche pendant le septième cycle (condition anormale), il doit soit être laissé à refroidir soit être remplacé dans le cas d'un appareil à simple action, et l'essai poursuivi en réglant le circuit et la température de telle manière que l'appareil de protection soit à la limite du déclenchement.

- f) *Dans le cas de luminaires comportant une fonction de flux lumineux constant, le luminaire doit fonctionner avec la sortie de l'appareillage de commande réglée de manière à fournir la puissance maximale à la source de lumière pour laquelle le luminaire a été conçu.*

NOTE Le fabricant peut avoir à fournir un échantillon d'essai préparé spécialement.

Il est considéré que si un coupe-circuit se déclenche pendant le septième cycle (condition anormale), le fonctionnement de l'appareil de protection prévu a dès lors été prouvé.

Il convient de prendre des dispositions afin de signaler une interruption de fonctionnement. La durée effective d'un essai ne doit pas être réduite par suite d'une telle interruption.

14.3.3 Conformité

Après l'essai du 14.3.2 le luminaire et, dans le cas de luminaires montés sur rail, le rail et les parties composantes du système de rails doivent être examinés visuellement. Aucune partie du luminaire ne doit être rendue inutilisable (autrement que pour une défaillance possible telle que décrite au 14.3.2, point e)) et les douilles à vis Edison en plastique ne doivent pas être déformées. Le luminaire ne doit pas être devenu dangereux ni avoir endommagé le système de rails. Le marquage du luminaire doit être lisible.

NOTE Les symptômes d'une détérioration dangereuse possible comprennent les fissures, les roussissements et les déformations.

14.4 Essai d'échauffement (fonctionnement normal)

14.4.1 Généralités

Dans les conditions représentant le fonctionnement normal, aucune partie du luminaire (y compris la source de lumière), du câblage d'alimentation à l'intérieur du luminaire ou de la surface de montage ne doit atteindre une température préjudiciable à la sécurité.

De plus, les parties susceptibles d'être touchées, saisies, réglées ou serrées à la main pendant que le luminaire est à sa température de fonctionnement ne doivent pas être chaudes au point d'empêcher cette action.

Les luminaires ne doivent pas provoquer un échauffement excessif des objets éclairés.

Les luminaires montés sur rail ne doivent pas provoquer un échauffement excessif des rails sur lesquels ils sont montés.

La conformité est vérifiée par la réalisation de l'essai décrit en 14.4.2. Les conditions d'essai pour le mesurage de la température du rail doivent être celles données dans l'IEC 60570:2003, 12.1.

Pour les luminaires qui contiennent un moteur électrique, ce moteur doit fonctionner durant l'essai comme il est prévu qu'il le fasse.

14.4.2 Essai

La température doit être mesurée comme cela est indiqué en 14.4.3, conformément aux conditions suivantes.

- a) *Le luminaire doit être soumis à l'essai dans une enceinte à air calme, conçue de façon à éviter des changements excessifs de la température ambiante. Un luminaire conçu pour pose en saillie doit être monté sur une surface comme celle décrite à l'Annexe D. Un exemple d'enceinte à air calme est décrit à l'Annexe D, mais d'autres types d'enceintes peuvent être utilisés si les résultats obtenus sont compatibles avec ceux qui seraient obtenus en utilisant l'enceinte décrite à l'Annexe D. (Pour les appareillages de commande séparés du luminaire, voir le 14.4.2, point h)).*

Le luminaire doit être connecté à la source d'alimentation au moyen du câblage et de tout matériel (par exemple gaines isolantes) fourni avec le luminaire à cette fin.

La connexion doit être conforme aux instructions fournies avec le luminaire ou marquées sur celui-ci. Il convient que le câblage exigé pour connecter à l'alimentation le luminaire en essai et non fourni avec celui-ci soit conforme à la pratique courante. Un tel câblage non fourni avec le luminaire est ci-après désigné comme élément d'essai.

Les mesurages de température doivent être effectués conformément à l'Annexe E et à l'Annexe I.

b) La position de fonctionnement doit être la position la plus défavorable thermiquement qui peut être raisonnablement adoptée en utilisation. Pour les luminaires fixes non réglables, une position ne doit pas être choisie s'il est établi qu'elle n'est pas admissible dans les instructions fournies avec le luminaire ou marquées sur celui-ci. La distance aux objets éclairés exigée pour les luminaires réglables et ajustables doit être respectée si elle est marquée sur le luminaire, exception faite des luminaires non équipés d'un dispositif mécanique de blocage en toute position, pour lequel le bord frontal du réflecteur, ou à défaut la lampe, doit être positionné à 100 mm de la surface de montage.

c) La température ambiante à l'intérieur de l'enceinte à air calme doit être maintenue dans la plage de 10 °C à 30 °C et il convient qu'elle soit préférentiellement de 25 °C. Elle ne doit pas varier de plus de ± 1 °C pendant les mesurages, ainsi que pendant une période précédant les essais suffisamment longue pour ne pas influencer les résultats.

Si, cependant, une lampe possède des caractéristiques électriques sensibles à la température (par exemple une lampe fluorescente) ou si la valeur assignée t_a du luminaire dépasse 30 °C, la température ambiante dans l'enceinte à air calme doit être égale, à 5 °C près, à la valeur assignée t_a , et il convient qu'elle soit préférentiellement égale à la valeur assignée t_a .

Une autre méthode d'essai est décrite à l'Article D.3. En cas de doute, la méthode d'essai du 14.4.2, point c) doit être considérée comme méthode d'essai de référence.

d) La tension d'essai du luminaire doit être la suivante.

- Luminaire pour lampes à filament autre que TBT: la tension qui produit 1,05 fois la puissance assignée de la lampe d'essai (voir Annexe B) à l'exception des lampes d'essai d'échauffement (EEE/HTS) qui fonctionnent toujours à la tension marquée sur la lampe.
- Pour les autres luminaires: 1,06 fois la tension assignée ou la valeur maximale de la plage de tensions assignée.
- Pour les moteurs contenus dans les luminaires: 1,06 fois la tension assignée (ou la valeur maximale de la plage de tensions assignée du luminaire).

Exception

Pour la détermination de la température moyenne d'enroulement d'un composant à marquage t_w , et pour la détermination de la température du boîtier d'un composant avec marquage t_c , excepté les condensateurs, la tension d'essai doit être de 1,00 fois la tension assignée. La présente exception s'applique seulement au mesurage de la température de l'enroulement ou du boîtier et ne s'applique pas, par exemple, au mesurage de température d'un bloc de jonction de connexion sur le même composant.

Les condensateurs, qu'ils comportent ou non t_c , sont soumis à l'essai à 1,06 fois la tension assignée lorsqu'ils fonctionnent avec des luminaires du type à fluorescence ou à décharge.

NOTE 1 Si un luminaire comporte à la fois une lampe à filament et une lampe tubulaire à fluorescence ou toute autre lampe à décharge, ou un moteur, il peut être nécessaire, pour cet essai, de prévoir provisoirement deux alimentations séparées.

Pour les luminaires non équipés d'un appareillage pour le fonctionnement à tension constante ou à courant constant, l'essai doit être effectué à 1,1 fois la tension constante d'entrée assignée ou 1,1 fois le courant constant d'entrée assigné, selon le cas.

Pendant les périodes de fonctionnement, la tension d'alimentation pour les luminaires de classe III alimentés par le biais d'un câblage de communication informatique doit être de:

- 106 % de la tension d'entrée assignée du luminaire au niveau des bornes d'alimentation.

e) Pendant et immédiatement avant un mesurage, la tension d'alimentation doit être maintenue à ± 1 %, et de préférence à $\pm 0,5$ %, de la tension d'essai. La tension d'alimentation doit être maintenue à ± 1 % de la tension d'essai pendant toute période précédant l'essai qui soit susceptible d'influencer les mesurages; cette période doit être d'au moins 10 min.

f) Les mesurages ne doivent pas être effectués avant que le luminaire ne soit stabilisé thermiquement, c'est-à-dire quand le taux de variation des températures est inférieur à 1 °C par heure.

- g) Si le luminaire cesse de fonctionner à cause d'une partie défectueuse de celui-ci (y compris la lampe), il convient de remplacer cette partie et de poursuivre l'essai. Le luminaire doit être stabilisé avant la réalisation des mesurages ultérieurs. Cependant, si un fonctionnement dangereux s'est manifesté ou si une partie quelconque devient hors de service en raison d'un défaut de type, alors le luminaire est considéré comme n'ayant pas satisfait à l'essai. Si un appareil de protection du luminaire fonctionne, le luminaire est jugé défectueux.
- h) Si les appareillages de commande ou des composants à distance sont fournis avec le luminaire, ils doivent être montés et mis en fonctionnement conformément aux instructions du fabricant. Les températures de toutes les parties doivent satisfaire aux limites spécifiées à l'Article 14.

Lorsque l'appareillage de commande à distance n'est pas fourni comme une partie du luminaire, le fabricant fournit un modèle type d'appareillage propre à l'usage normal. Celui-ci doit être mis en fonctionnement à l'air libre et à une température ambiante de $25\text{ °C} \pm 5\text{ °C}$, et doit fournir le paramètre de sortie mentionné au point d). La température de l'appareillage de commande ne doit pas être mesurée.

- i) En cas de doute dans l'essai de luminaires pour lampes à filament, l'essai doit être répété avec des lampes sources pour essai d'échauffement (EEE/HTS), si elles existent. Pour les températures influencées surtout par la température du culot de la lampe, les valeurs obtenues par les lampes EEE/HTS sont concluantes. Pour les températures principalement liées au rayonnement, les valeurs obtenues avec des lampes de production normale à ampoules claires sont concluantes.
- j) Le faisceau lumineux du luminaire, pour les luminaires couverts par le 6.3.13, est dirigé vers une surface verticale en bois peint en noir mat montée perpendiculairement à la direction principale de la lumière et similaire à celle décrite à l'Annexe D. Lorsque plus d'une lampe est utilisée, la lampe centrale doit être dirigée comme cela est spécifié ci-dessus. Toutes les autres lampes doivent être dirigées afin d'obtenir un foyer commun. Les luminaires sont montés à la distance par rapport à la surface qui est marquée sur le luminaire.

Pendant les essais, des mesurages de température de certaines parties isolantes doivent être effectués, comme cela est exigé pour les essais de l'Article 15.

- k) Pour les mesurages de température des douilles de lampes fluorescentes à deux culots, le point chaud du thermocouple doit être situé au ras de la surface de la douille adjacente au culot de la lampe. Si cela n'est pas possible, il convient de le placer aussi près que possible de ce point, mais sans toucher le culot de la lampe.

NOTE 2 Le fabricant de luminaires peut fournir l'échantillon d'essai de type avec un thermocouple déjà fixé à la douille de la lampe. Habituellement, une seule douille est préparée de cette manière.

- l) Pendant l'essai de conformité, la ligne traversante et le câblage de repiquage doivent être alimentés à la valeur maximale autorisée par la taille du câble, ou à une valeur spécifiée par le fabricant dans les instructions d'installation. Le socle de prise de courant, s'il existe, est parcouru par le courant à la valeur déclarée par le fabricant et, sans indication, à son courant assigné à la tension assignée.

NOTE 3 Dans les pays suivants, pendant l'essai d'échauffement, il est exigé que la ligne traversante et le câblage de repiquage soient tous deux alimentés à la valeur maximale autorisée par la taille du câble: Canada, États-Unis.

- m) Dans le cas de luminaires comportant une fonction de flux lumineux constant, le luminaire doit fonctionner avec la sortie de l'appareillage de commande réglée de manière à fournir la puissance maximale à la source de lumière pour laquelle le luminaire a été conçu.

NOTE 4 Le fabricant peut avoir à fournir un échantillon d'essai préparé spécialement.

14.4.3 Conformité

Dans l'essai du 14.4.2, aucune des températures ne doit dépasser les valeurs appropriées données dans le Tableau 21 et le Tableau 22 (exception faite de la concession du point a) du présent paragraphe) lorsque le luminaire fonctionne à sa température ambiante assignée t_a .

Dans les cas où la température de l'enceinte d'essai diffère de t_a , cette différence doit être prise en compte lors de l'application des limites spécifiées dans le Tableau 21 et le Tableau 22 (voir aussi 14.4.2, point c)).

- a) *La température ne doit pas dépasser de plus 5 °C les valeurs spécifiées dans le Tableau 21 et le Tableau 22.*

NOTE La tolérance de 5 °C a pour objet de tenir compte de l'inévitable dispersion des mesurages de température dans les luminaires.

- b) *La température de toute partie du luminaire susceptible de subir une dégradation thermique en service ne doit pas dépasser une valeur correspondant à une période de service raisonnable pour le type particulier de luminaire. Les valeurs généralement admises pour les parties principales des luminaires sont indiquées dans le Tableau 21 et les valeurs pour les matériaux courants, lorsqu'ils sont utilisés dans des luminaires, sont indiquées dans le Tableau 22. Ces valeurs sont spécifiées ici pour réaliser une évaluation uniforme; des valeurs légèrement différentes peuvent être citées ailleurs d'après d'autres types d'essais de matériaux ou pour d'autres applications.*

Si des matériaux réputés supporter de plus hautes températures que celles spécifiées dans le Tableau 22 sont utilisés, ou si d'autres matériaux sont utilisés, ils ne doivent pas être soumis à des températures supérieures à celles pour lesquelles il a été prouvé qu'elles sont admissibles pour ces matériaux.

- c) *La température de l'élément d'essai (voir 14.4.2, point a)), s'il est isolé au PVC, ne doit pas dépasser 90 °C (ou 75 °C s'il subit une contrainte, par exemple s'il est serré), ou toute température plus élevée marquée sur le luminaire ou dans les instructions du fabricant fournies avec le luminaire selon les exigences de l'Article 6. La limite doit être de 120 °C pour tout câble isolé au PVC (câblage interne ou externe) même si ce câble comporte une protection additionnelle, procurée par une gaine résistant à la chaleur et fournie avec le luminaire. La gaine doit satisfaire aux exigences du 7.9.2.*

Tableau 21 – Températures maximales dans les conditions d'essai du 14.4.3 pour les parties principales

Partie	Température maximale °C
Culots de lampes	Comme cela est spécifié dans la norme de lampe IEC appropriée^a
Enroulements des ballasts ou transformateurs marqués t_w	t_w
Boîtier (de condensateur, appareils d'amorçage, appareillage de commande ou convertisseur électronique, module LED, etc.)	
Si t_c est marquée	t_c^b
Pour le condensateur si t_c n'est pas marquée	50
Enroulements de transformateurs, moteurs, etc., si le système d'isolation de l'enroulement selon l'IEC 60085 est:	
– en matériau de classe A ^c	100
– en matériau de classe E ^c	115
– en matériau de classe B ^c	120
– en matériau de classe F ^c	140
– en matériau de classe H ^c	165
Isolation du câblage:	Voir Tableau 22 et 14.4.3, points b) et c)
Contacts des douilles en céramique et matériau isolant des douilles de lampe et de starter:	
Marqués T1 ou T2 (B15 et B22) ^d (IEC 61184)	165 pour T1 et 210 pour T2
Autres types avec marquage T	
(IEC 60238, IEC 60400, série IEC 60838 ^e et IEC 61184)	Marquage T
Autres types sans marquage T	
(E14, B15) (IEC 60238 et IEC 61184)	135
(E27, B22) (IEC 60238 et IEC 61184) (E26)	165
(E40) (IEC 60238) (E 39)	225
Douilles pour lampes à fluorescence, douilles de starter et diverses douilles sans marquage T (IEC 60400 et série IEC 60838 ^e)	80
Interrupteurs portant la marque de leurs caractéristiques individuelles:	
Avec marquage T	Marquage T
Sans marquage T	55
Interrupteurs conformes à l'IEC 60669-1 ou à l'IEC 60669-2-1	35 ^h
Autres parties du luminaire (selon le matériau et l'utilisation):	Voir Tableau 22 et 14.4.3, point b)
Surface de montage:	
Surface normalement inflammable	90
Surface non combustible	Non mesurée
Moyens de réglage et son espace environnant ^f	
Parties métalliques	60
Parties non métalliques	75
Objets éclairés par projecteurs (voir 14.4.2 j)):	90 (à la surface d'essai)
Rails (pour les luminaires montés sur rail)	Comme cela est spécifié par le fabricant du rail ^g

Partie	Température maximale °C
Culots de lampes	Comme cela est spécifié dans la norme de lampe IEC appropriée^a
Appareillage de commande indépendant enfichable:	
– parties de boîtier destinées à être saisies à la main	75
– interface fiche/socle de prise de courant	70
– toutes les autres parties	85
Appareils de démarrage à leur remplaçables	80 ⁱ
Surface de luminaires encastrés au-dessus d'un plafond suspendu, recouverts d'un matériau isolant thermique	90
<p>^a Pour les luminaires marqués avec des indications relatives à l'emploi de lampes spéciales, ou s'il est évident que des lampes spéciales doivent être utilisées, une valeur plus élevée est admise, comme cela est spécifié par le fabricant de lampes. L'IEC 60357 et l'IEC 60682 fournissent des indications pour les mesurages de la température du pincement des lampes tungstène-halogène. Ces mesurages sont exigés pour les critères de performance des lampes et non pour la sécurité du luminaire. (Les lampes à fluorescence à culot unique sont dispensées de ces mesurages dans les conditions d'essai de fonctionnement normal, voir Tableau 23). Cela ne s'applique pas aux lampes couvertes par le domaine d'application de l'IEC 60432-2. Les indications correspondantes dans le présent document pour la conception des luminaires doivent être observées.</p> <p>^b Mesurée au point de référence marqué par le fabricant de l'appareil.</p> <p>^c La classification des matériaux est conforme à l'IEC 60085 et à la série IEC 60216.</p> <p>^d Température mesurée sur le bord du culot correspondant.</p> <p>^e Pour les douilles à deux broches, en cas de doute, il convient d'utiliser la moyenne des résultats de mesure des températures de contact.</p> <p>^f Pour des luminaires ajustables, dont les instructions de montage indiquent une procédure claire pour monter le luminaire dans un volume non accessible au toucher, et pour les luminaires réglables, les limites de température des dispositifs de réglage ne sont pas applicables.</p> <p>^g Pour les conditions de mesure de la température du rail, voir l'IEC 60570:2003, 12.1.</p> <p>^h Cette limite de température est la température ambiante mesurée le plus près possible de l'interrupteur.</p> <p>ⁱ Cette limite de température est destinée aux performances et ne constitue pas une recommandation de sécurité.</p>	

Tableau 22 – Températures maximales dans les conditions d'essai du 14.4.3 pour les matériaux communs utilisés dans les luminaires

Partie	Température maximale °C
Isolation de câbles (interne et externe) fournis avec le luminaire ^b :	
Fibre de verre imprégnée de vernis silicone	200 ^a
Polytétrafluoroéthylène (PTFE)	250
Caoutchouc au silicone (non contraint)	200
Caoutchouc au silicone (à contrainte compressive seulement)	170
Caoutchouc ou polychlorure de vinyle ordinaire (PVC)	90 ^a
Polychlorure de vinyle résistant à la chaleur (PVC)	105 ^a
Acétate de vinyle éthylénique (AVE)	140 ^a
Isolation du câblage de l'installation fixe (en tant que partie fixe non fournie avec le luminaire) ^a :	
Sans gaine	90 °C
Avec gaine appropriée fournie avec le luminaire	120

Partie	Température maximale °C
Thermoplastiques:	
Acrylonitrile-butadiène-styrène (ABS)	95
Acétobutyrate de cellulose (ABC)	95
Méthacrylate de polyméthyle (acrylique)	90
Polystyrène	75
Polypropylène	100
Polycarbonate	130
Polychlorure de vinyle (PVC) (lorsque non utilisé sur l'isolation électrique)	100
Polyamide (nylon)	120
Plastiques thermodurcissables:	
Formaldéhyde de phénol à charge minérale (FP)	165
Formaldéhyde de phénol à charge de cellulose (FP)	140
Urée-Formol (UF)	90
Mélamine	100
Polyester renforcé de fibre de verre (PRV)	130
Autres matériaux:	
Papier ou tissu en fibres imprégné de résines	125
Caoutchouc au silicone (lorsque non utilisé pour l'isolation électrique)	230
Caoutchouc (lorsque non utilisé pour l'isolation électrique)	90
Bois, papier, textiles et similaires	90
Aimant permanent utilisé pour la suspension du luminaire ou de la partie du luminaire	Température maximale de fonctionnement continu déclarée par le fabricant de l'aimant
<p>^a Réduite de 15 °C lorsque l'isolation est contrainte, serrée ou pliée, par exemple.</p> <p>^b Les spécifications des câbles indiquent habituellement des températures maximales différentes, mais celles-ci reposent sur des températures de fonctionnement en continu plutôt que sur les conditions d'essais indiquées dans le présent document.</p> <p>^c Cette température est la valeur maximale admise dans les conditions d'essai artificielles indiquées dans le présent tableau, par exemple une enceinte à air calme et une tension d'essai supérieure à la tension assignée du luminaire. Il est important de noter que, dans certains pays, les règles d'installation européennes et les normes européennes de câbles spécifient une température de 70 °C comme température maximale que les câbles PVC d'installation fixe peuvent supporter dans les conditions normales de fonctionnement en continu.</p>	

14.5 Essai d'échauffement (fonctionnement anormal)

14.5.1 Généralités

Dans les conditions représentant celles du service anormal (là où elles s'appliquent, mais ne représentant pas un défaut dans le luminaire ou un mauvais emploi), les parties du luminaire et la surface de montage ne doivent pas atteindre de températures excessives et le câblage à l'intérieur du luminaire ne doit pas devenir dangereux.

NOTE Les symptômes d'une détérioration dangereuse possible comprennent les fissures, les roussissements et les déformations.

Les luminaires montés sur rail ne doivent pas provoquer un échauffement excessif des rails sur lesquels ils sont montés.

La conformité est vérifiée par la réalisation de l'essai décrit en 14.5.2.

14.5.2 Essai

Les températures des parties désignées dans le Tableau 23 doivent être mesurées dans les conditions suivantes.

- a) L'essai doit être effectué si, en fonctionnement, le luminaire peut se trouver dans une des conditions anormales définies aux cas 1), 2), 3), 4) ou 5) ci-dessous, et si cette condition est susceptible d'entraîner, pour une partie quelconque, une température supérieure à celle du fonctionnement normal (pour laquelle un essai préliminaire peut être nécessaire).

Si plus d'une condition anormale est possible, la condition choisie doit être celle qui influence le plus défavorablement les résultats des essais.

L'essai n'est pas applicable aux luminaires fixes et non réglables en cours d'utilisation, pour lampes à filament, à l'exception du cas 3) ci-dessous.

- 1) Une position possible de fonctionnement dangereux, ayant une cause autre qu'un mauvais emploi, par exemple si, par accident, un luminaire ajustable est incliné dans la direction de la surface de montage en utilisant une force de 30 N au minimum pendant un court instant et à l'endroit le plus défavorable du luminaire.
- 2) Une condition possible de circuit dangereux ayant une autre cause qu'une fabrication défectueuse ou un mauvais emploi; par exemple un état du circuit se produisant en fin de durée de vie d'une lampe ou d'un starter (voir Annexe C).
- 3) Une condition possible de fonctionnement dangereux ayant pour cause l'emploi d'une lampe d'éclairage général dans un luminaire pour lampe à filament prévu pour une lampe spéciale, par exemple si une lampe spéciale est remplacée provisoirement par une lampe d'éclairage général de même puissance.
- 4) Une condition possible de fonctionnement dangereux ayant pour cause un court-circuit dans le circuit de sortie d'un luminaire avec transformateur (y compris le transformateur et le convertisseur abaisseur électronique lui-même) d'un luminaire avec transformateur ou convertisseur abaisseur électronique adapté à l'alimentation de la tension lampe.
- 5) Une condition possible de fonctionnement dangereux ayant pour cause une surtension pour un luminaire alimenté par le biais d'un câblage de communication informatique.

L'essai 2) est seulement applicable aux luminaires pour lampes tubulaires à fluorescence et autres lampes à décharge.

L'essai 4) doit être réalisé avec une douille en court-circuit. Pendant l'essai 4), l'élévation de température sur la surface de montage, due à la chaleur provenant de la lampe doit être vérifiée par l'essai du point 1), tandis que l'élévation de température due à la chaleur provenant du transformateur ou du convertisseur abaisseur électronique doit être mesurée, les contacts de la douille étant en court-circuit.

Les luminaires qui contiennent un moteur électrique fonctionnent avec le rotor bloqué.

Il convient de réaliser l'essai selon les conditions les plus critiques (voir Annexe C) en cas de présence d'un ou de plusieurs moteurs.

Le luminaire doit être soumis à l'essai dans les conditions spécifiées en 14.4.2, points a), c), e), f), h) et l). En outre, ce qui suit doit s'appliquer:

- b) La tension d'essai doit être appliquée comme suit:

Luminaires pour lampes à filament: comme cela est spécifié au 14.4.2, point d).

Luminaires pour lampes tubulaires à fluorescence et autres lampes à décharge: 1,1 fois la tension assignée ou la valeur maximale de la plage de tensions assignée.

Pour les moteurs contenus dans les luminaires: 1,1 fois la tension assignée (ou la valeur maximale de la plage de tensions assignée du luminaire).

Luminaires qui contiennent un transformateur ou des convertisseurs lors d'un court-circuit conformément à l'essai 4): entre 0,9 et 1,1 fois la tension d'alimentation assignée, si cette donne le cas le plus défavorable.

Pendant les périodes de fonctionnement, la tension d'alimentation pour les luminaires de classe III alimentés par le biais d'un câblage de communication informatique doit être de:

- *130 % de la tension d'entrée assignée du luminaire au niveau des bornes d'alimentation pour les circuits supérieurs à 5 V en courant continu, avec un minimum de 7,5 V en courant continu, et*
- *150 % de la tension d'entrée assignée du luminaire au niveau des bornes d'alimentation pour les circuits inférieurs ou égaux à 5 V en courant continu.*

NOTE 1 Si un luminaire comporte à la fois une lampe à filament et une lampe tubulaire à fluorescence ou toute autre lampe à décharge, ou un moteur, il peut être nécessaire, pour cet essai, de prévoir provisoirement deux alimentations séparées.

Pour les luminaires non équipés d'un appareillage pour le fonctionnement à tension constante ou à courant constant, l'essai doit être effectué à 1,1 fois la tension constante d'entrée assignée ou 1,1 fois le courant constant d'entrée assigné, selon le cas.

- c) *Si le luminaire cesse de fonctionner à cause d'une partie défectueuse de celui-ci (y compris la lampe), il convient de remplacer cette partie et de poursuivre l'essai. Le luminaire doit être stabilisé avant la réalisation des mesurages ultérieurs. Cependant, si un fonctionnement dangereux s'est manifesté ou si une partie quelconque devient hors de service en raison d'un défaut de type, alors le luminaire est considéré comme n'ayant pas satisfait à l'essai.*

Si un appareil de protection du luminaire (par exemple un coupe-circuit thermique ou un coupe-circuit, du type à une seule opération ou "à réarmement automatique") fonctionne pendant l'essai, il convient que les températures atteintes les plus élevées soient retenues comme températures finales.

- d) *Si le luminaire comporte un condensateur (autre que celui qui est placé directement aux bornes du réseau), ce condensateur doit être court-circuité, en dépit des exigences de l'Annexe C, si la tension qui lui est appliquée dans les conditions de l'essai dépasse 1,25 fois sa tension assignée dans le cas des condensateurs autorégénérateurs ou 1,3 fois sa tension assignée dans le cas des condensateurs non autorégénérateurs.*

Les luminaires qui utilisent certaines lampes aux halogénures métalliques et les luminaires qui utilisent certaines lampes à vapeur de sodium haute pression qui peuvent conduire, selon les spécifications des lampes, à la surchauffe du ballast, du transformateur ou de l'appareil d'amorçage sont soumis à l'essai conformément à l'Annexe C, point b) 2).

- e) *Dans le cas de luminaires comportant une fonction de flux lumineux constant, le luminaire doit fonctionner avec la sortie de l'appareillage de commande réglée de manière à fournir la puissance maximale à la source de lumière pour laquelle le luminaire a été conçu.*

NOTE 2 Le fabricant peut avoir à fournir un échantillon d'essai préparé spécialement.

14.5.3 Conformité

Dans l'essai du 14.5.2, aucune des températures ne doit dépasser la valeur appropriée donnée dans le Tableau 23, le Tableau 24 et le Tableau 25 de plus de 5 °C lorsque le luminaire fonctionne à sa température ambiante assignée t_a . Au cas où la température de l'enceinte d'essai diffère de t_a , cette différence doit être prise en compte lors de l'application des limites spécifiées dans le tableau correspondant.

Tableau 23 – Températures maximales dans les conditions de l'essai du 14.5.2

Partie	Température maximale °C
Culots de lampes à fluorescence à culot unique	Comme cela est spécifié dans la norme de lampe IEC appropriée^c
Enroulements dans les ballasts ou les transformateurs marqués tw ^a	Voir Tableau 24 et Tableau 25
Enroulements de transformateurs moteurs, etc., si le système d'isolation de l'enroulement selon l'IEC 60085 est:	
– en matériau de classe A ^b	150
– en matériau de classe E ^b	165
– en matériau de classe B ^b	175
– en matériau de classe F ^b	190
– en matériau de classe H ^b	210
Boîtier du condensateur:	
– si t_c n'est pas marquée	60
– si t_c est marquée	$t_c + 10$
Cas d'amorceur	$(t_c + X)$ comme cela est marqué sur l'amorceur
Surface de montage:	
– surface éclairée par la lampe (luminaire réglable et ajustable selon le 14.5.2 a) 1)	175
– surface chauffée par la lampe (luminaire portable selon l'IEC 60598-2-4:2017, 4.13)	175
– surface normalement inflammable	130
– surface non combustible (luminaires avec symbole ou notice d'avertissement)	Non mesurée
Rails (pour les luminaires montés sur rail)	Indiqués par le fabricant de rails
Luminaires montés sur socle de prise de courant réseau et parties de boîtiers d'appareillage de commande ou de transformateur à fiche destinés à être serrés à la main	75
Surface de luminaires encastrés au-dessus d'un plafond suspendu, recouverts d'un matériau isolant thermique	130
<p>^a Les températures limites spécifiées à la colonne S4.5 du Tableau 24 ou du Tableau 25 s'appliquent, sauf marquage contraire sur le ballast.</p> <p>^b La classification des matériaux est conforme à l'IEC 60085 et à la série IEC 60216.</p> <p>^c Les informations concernant le ou les points de mesure et les limites de température sont données dans l'IEC 61199:2011, Annexe C, l'IEC 61199:2011/AMD1:2012, Annexe C, et l'IEC 61199:2011/AMD2:2014, Annexe C.</p>	

Tableau 24 – Températures maximales des enroulements dans des conditions de fonctionnement anormales et à 110 % de la tension assignée pour l'appareillage de commande

		Température maximale					
		°C					
Constante S		S4.5	S5	S6	S8	S11	S16
Pour $t_w =$	90	171	161	147	131	119	110
	95	178	168	154	138	125	115
	100	186	176	161	144	131	121
	105	194	183	168	150	137	126
	110	201	190	175	156	143	132
	115	209	198	181	163	149	137
	120	217	205	188	169	154	143
	125	224	212	195	175	160	149
	130	232	220	202	182	166	154
	135	240	227	209	188	172	160
	140	248	235	216	195	178	166
	145	256	242	223	201	184	171
	150	264	250	230	207	190	177

Tableau 25 – Températures maximales des enroulements dans les conditions de fonctionnement anormales et à 110 % de la tension assignée pour les appareillages de commande marqués "D6"

		Température maximale					
		°C					
Constante S		S4.5	S5	S6	S8	S11	S16
Pour $t_w =$	90	158	150	139	125	115	107
	95	165	157	145	131	121	112
	100	172	164	152	137	127	118
	105	179	171	158	144	132	123
	110	187	178	165	150	138	129
	115	194	185	171	156	144	134
	120	201	192	178	162	150	140
	125	208	199	184	168	155	145
	130	216	206	191	174	161	151
	135	223	213	198	180	167	156
	140	231	220	204	186	173	162
	145	238	227	211	193	179	168
	150	246	234	218	199	184	173

Pour les appareillages de commande soumis à un essai d'endurance d'une durée autre que 30 jours ou 60 jours, il convient d'utiliser l'Équation (2) de l'IEC 61347-1:2015, Article 13, pour calculer la température maximale correspondant au nombre de jours égal aux deux tiers de l'essai d'endurance théorique.

(Une explication de la constante S et de son utilisation est donnée dans la norme auxiliaire correspondante de l'IEC.)

14.6 Essai d'échauffement (concerne la défaillance des enroulements des appareillages de commande)

14.6.1 Généralités

Ces essais s'appliquent uniquement aux luminaires classés pour être installés sur des surfaces normalement inflammables et qui incorporent un appareillage de commande qui ne satisfait pas aux exigences d'espacement du 7.16.2 ou qui ne procure pas la protection thermique conformément au 7.16.3. Les appareillages de commande électroniques pour les petits appareils bobinés qui peuvent être intégrés à ces composants sont dispensés des exigences du 14.6.

14.6.2 Essai pour les luminaires sans coupe-circuit thermiques

Le luminaire doit être soumis à l'essai dans les conditions spécifiées en 14.4.2, points a), c), e), f), h) et l). De plus, ce qui suit s'applique également:

20 % des circuits du luminaire, et au moins un circuit lampe, doivent être soumis aux conditions anormales (voir 14.5.2, point a)).

Les circuits qui ont la plus grande influence thermique sur la surface de montage doivent être choisis, et les autres circuits lampes doivent fonctionner à la tension assignée ou à la valeur maximale de la plage de tensions assignée dans les conditions normales.

Les circuits soumis aux conditions ci-dessus doivent ensuite fonctionner à 0,9, 1,0 et 1,1 fois la tension assignée (ou la valeur maximale de la plage de tensions assignée). Lorsque les conditions de stabilité sont atteintes pour chacune de ces trois tensions d'essai, la température de l'enroulement la plus haute et la température la plus élevée de toute partie de la surface de montage doivent ensuite être mesurées.

Pour les luminaires à lampes fluorescentes équipés d'un appareillage électronique d'alimentation qui fonctionne en courant alternatif et qui incorpore une bobine de filtrage, la tension exigée pour donner le courant de fonctionnement nominal doit être déterminée. La bobine de filtrage doit fonctionner à 0,9, 1,0 et 1,1 fois cette tension. Lorsque les conditions de stabilité sont atteintes pour chacune de ces trois tensions d'essai, la température de l'enroulement la plus haute et la température la plus élevée de toute partie de la surface de montage doivent ensuite être mesurées. Toutes les autres parties de l'appareillage de commande et de la lampe doivent être inactives pendant l'essai.

La conformité est vérifiée comme suit.

- a) la température de la surface de montage ne doit pas dépasser 130 °C quand le ou les circuits lampes sont soumis aux conditions anormales de fonctionnement à 1,1 fois la tension assignée;*
- b) les valeurs de température mesurées à 0,9, 1,0 et 1,1 fois la tension assignée (ou la valeur maximale de la plage de tensions assignée) sont utilisées dans la formule de régression linéaire en calculant la température de la surface de montage en relation avec la température de 350 °C de l'enroulement du ballast ou du transformateur. Si la différence entre les mesures de température d'enroulement pour les coordonnées 0,9 et 1,1 est inférieure à 30 K, un quatrième point de mesure est reporté sur le graphique dont les coordonnées sont température d'enroulement t_a , température de la surface de montage t_s . La meilleure ligne droite est tracée au plus proche des points sur le graphique. La température estimée de la surface de montage correspondant à une température de l'enroulement du ballast de 350 °C ne doit pas excéder 180 °C;*

NOTE t_a est la t_a assignée du luminaire.

- c) pour les luminaires montés sur rail, aucune partie du rail ne doit présenter une détérioration dangereuse, par exemple des craquelures, des roussissements ou des déformations.

14.6.3 Essai pour les luminaires avec appareils de contrôle sensibles à la température

L'essai est exigé pour les luminaires avec appareils de contrôle sensibles à la température extérieurs à l'appareillage de commande ou au transformateur et pour les luminaires à appareillage de commande à protection thermique, marqué du symbole  avec une valeur supérieure à 130 °C.

Le luminaire doit être monté pour cet essai comme cela est décrit en 14.6.2.

Les circuits soumis aux conditions ci-dessus doivent être mis en fonctionnement sur un courant d'enroulement croissant lentement et régulièrement jusqu'à ce que le coupe-circuit agisse. Les intervalles de temps et les augmentations de courant doivent être tels que l'équilibre de température entre les enroulements et la surface de montage soit réalisé dans toute la mesure possible.

Durant l'essai, la température de la partie la plus élevée de la surface sur laquelle le luminaire est monté doit être mesurée continuellement. Ce mesurage achève l'essai des luminaires équipés de protecteurs thermiques.

Pour les luminaires équipés de coupe-circuit à réarmement manuel, l'essai doit être répété trois fois avec un intervalle de 30 min entre les essais. À la fin de chaque intervalle de 30 min, le coupe-circuit doit être réarmé.

Pour les luminaires équipés de coupe-circuit thermiques à réarmement automatique, l'essai doit être poursuivi jusqu'à ce qu'une température de surface de montage stable soit atteinte. Dans les conditions données, le coupe-circuit à réarmement automatique doit se déclencher trois fois en coupant, puis en mettant en circuit l'appareillage de commande.

Les transformateurs associés qui ne sont pas soumis à l'essai avec leur propre enveloppe doivent être soumis à l'essai, puisque ces caractéristiques ne sont pas vérifiées par la norme des composants.

La conformité est vérifiée comme suit.

Durant l'essai, aucune partie de la surface d'appui ne doit atteindre une température supérieure à 135 °C, ni présenter une température supérieure à 110 °C lorsque le protecteur referme le circuit (protecteur du type à réarmement) excepté que:

durant tout cycle de fonctionnement du protecteur, pendant l'essai, la température de la surface peut être supérieure à 135 °C à condition que la longueur de temps entre l'instant où la température de surface dépasse la limite pour la première fois et celui où la température maximale indiquée dans le Tableau 26 est atteinte n'excède pas la durée correspondante donnée par ce tableau.

Tableau 26 – Limite du temps de dépassement de la température

Température maximale de la surface de montage °C	Temps maximal pour atteindre la température maximale à partir de 135 °C min
plus de 180	0
entre 175 et 180	15
entre 170 et 175	20
entre 165 et 170	25
entre 160 et 165	30
entre 155 et 160	40
entre 150 et 155	50
entre 145 et 150	60
entre 140 et 145	90
entre 135 et 140	120

Après l'essai, ce qui suit s'applique.

La température de la partie la plus élevée de la surface de montage ne doit pas excéder 180 °C à un instant quelconque durant les essais des protecteurs thermiques et des coupe-circuit thermiques à réarmement manuel, ou 130 °C durant les essais des coupe-circuit thermiques à réarmement automatique.

Pour les luminaires montés sur rail, aucune partie du rail ne doit présenter, après l'essai, une détérioration dangereuse, par exemple des craquelures, des roussissements ou des déformations.

14.7 Essai d'échauffement en rapport avec des conditions défectueuses des appareillages de commande ou des dispositifs électroniques incorporés dans des luminaires en matière thermoplastique

14.7.1 Généralités

L'essai s'applique uniquement aux luminaires avec enveloppe thermoplastique non équipés de dispositifs mécaniques supplémentaires, indépendants de la température, conformément au 7.15.2.

Cet essai ne doit pas être réalisé sur les transformateurs indépendants avec leur propre enveloppe satisfaisant à la série IEC 61558 et sur les appareillages de commande indépendants avec leur propre enveloppe satisfaisant à la série IEC 61347.

14.7.2 Essai pour les luminaires sans appareils de contrôle sensibles à la température

14.7.2.1 Essai pour les luminaires incorporant un ou des ballasts de lampes fluorescentes ≤ 70 W

Trois luminaires doivent être soumis à l'essai dans les conditions spécifiées en 14.4.2, points a), b), c), e) et h). De plus, ce qui suit s'applique.

Le ballast choisi pour l'essai (qui a l'influence thermique la plus importante sur les points de fixation, la surface de montage et les parties exposées, placé à l'intérieur du luminaire selon la conception du luminaire) doit être alimenté directement à 1,1 fois la tension assignée pendant 4 h (période de mise en condition), selon la Figure 44.